

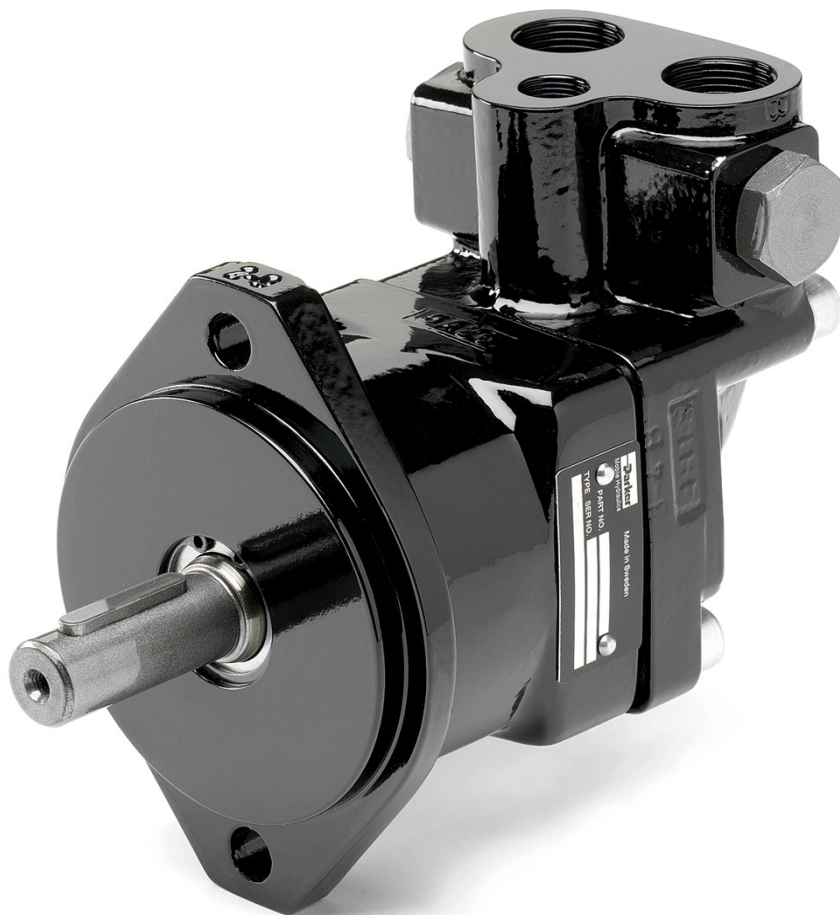

F11 Series Axial Piston Fixed Motors Repair Manual



List of contents	Page
General information	3
Specification and Operating Temperature	4
Design	5
Operational Check.....	6
Assembly.....	7 - 10
Barrel Retaining Ring	11
Torque and Gear Backlash.....	12
Split view	13
Parts specification	14
Saw Motor and Make Up Valve	15
Valve Plates.....	16

Conversion factors	
1 kg	= 2.2046 lb
1 N	= 0.22481 lbf
1 bar	= 14.504 psi
1 l	= 0.21997 UK gallon
1 l	= 0.26417 US gallon
1 cm ³	= 0.061024 in ³
1 m	= 3.2808 feet
1 mm	= 0.03937 in
1 °C	= 1.8°F + 32

 **WARNING**

FAILURE OR IMPROPER SELECTION OR IMPROPER USE OF THE PRODUCTS AND/OR SYSTEMS DESCRIBED HEREIN OR RELATED ITEMS CAN CAUSE DEATH, PERSONAL INJURY AND PROPERTY DAMAGE.

This document and other information from Parker Hannifin Corporation, its subsidiaries and authorized distributors provide product and/or system options for further investigation by users having technical expertise. It is important that you analyze all aspects of your application, including consequences of any failure, and review the information concerning the product or system in the current product catalogue. Due to the variety of operating conditions and applications for these products or systems, the user, through its own analysis and testing, is solely responsible for making the final selection of the products and systems and assuring that all performance, safety and warning requirements of the application are met.

The products described herein, including without limitation, product features, specifications, designs, availability and pricing, are subject to change by Parker Hannifin Corporation and its subsidiaries at any time without notice.

General information

F11 is bent axis, fixed displacement heavy-duty motor/pump series. They can be used in numerous applications in both open and closed loop circuits.

Series F11 is available in the following frame sizes and versions:

- F11-5, -6, -10, -12, -14 and -19 with CETOP mounting flange and shaft end.
- F11-6, -10, -12 and -14 with ISO flange and shaft
- F11-6, -10, -12, -14 and -19 with SAE flange and shaft

Thanks to the unique spherical piston design, F11 motors can be used at unusually high shaft speeds. Operating pressures to 420 bar provides for the high output power capability.

The 40° angle between shaft and cylinder barrel allows for a very compact, lightweight motor/pump.

The laminated piston ring offers important advantages such as low internal leakage and thermal shock resistance.

The pump version has highly engineered valve plates for increased selfpriming speed and low noise, available with left and right hand rotation.

The F11 motors produce very high torque at start-up as well as at low speeds.

Our unique timing gear design synchronizes shaft and cylinder barrel, making the F11 very tolerant to high 'G' forces and torsional vibrations.

Heavy duty roller bearings permit substantial external axial and radial shaft loads.

The F11's have a simple and straightforward design with very few moving parts, making them very reliable motors/pumps.

The unique piston locking, timing gear and bearing set-up as well as the limited number of parts add up to a very robust design with long service life and, above all, proven reliability.

Note! F11-150 and -250 have been updated to F12-150 and -250. They can be found in the service manual for F12. We also refer to after sales information, SI 09/01 and SI 09/04.

Specifications

Size F11	-5	-6	-10	-12	-14	-19
Displacement (cm ³ /rev)	4,9	6,0	9,8	12,5	14,3	19,0
Operating Pressure (bar)						
Max intermittent ¹⁾	420	420	420	420	420	420
Max continuous	350	350	350	350	350	350
Motor operating speed (rpm)						
Max intermittent ¹⁾	14000	11200	11200	10300	9900	8900
Max continuous	12800	10200	10200	9400	9000	8100
Min continuous	50	50	50	50	50	50
Max pump self priming speed (rpm)						
L or R operation ²⁾	4600	-	4200	3900	3900	3500
Motor input flow (l/min)						
Max intermittent ¹⁾	69	67	110	129	142	169
Max continuous	63	61	100	118	129	154
Main circuit temp.						
Max (°C)	80	80	80	80	80	80
Min (°C)	-40	-40	-40	-40	-40	-40
Mass moment of inertia (x10 ⁻³) (kg m ²)	7,8	9,5	15,6	19,8	22,7	30,2
Weight (kg)	4,7	7,5	7,5	8,2	8,3	11

¹⁾ Intermittent: max 6 seconds in any one minute.

²⁾ Self priming speed valid at sea level.

Operating temperature

The following temperatures should not be exceeded (Type **N** shaft seals): Drain fluid: 90 °C.

FPM shaft seals (type **V**) can be used to 115 °C drain fluid temperature.

Note: The temperature should be measured at the utilized drain port.

Continuous operation may require case flushing in order to meet the viscosity and temperature limitations.

For further information we refer to:
Catalogue HY30-8249/UK

Design

Series F11 pumps/motors consist of a rotating group contained in a split housing. Spherical pistons (1) with laminated piston rings (2) operate at a 40° angle relative to the shaft (3). As the shaft turns, the pistons are driven in a reciprocating movement in the cylinder barrel (4). When the unit is used as a pump, the oil passes from the inlet port to the cylinder barrel and is then forced to the outlet port through the pumping action of the pistons. A barrel retaining ring maintains the barrel against the valve plate (5). A ring gear (6) on the shaft meshes with the corresponding teeth of the cylinder barrel (4) so that the cylinder barrel always rotates at the same speed as the shaft (3). The shaft is supported by two heavy duty tapered roller bearings (7).

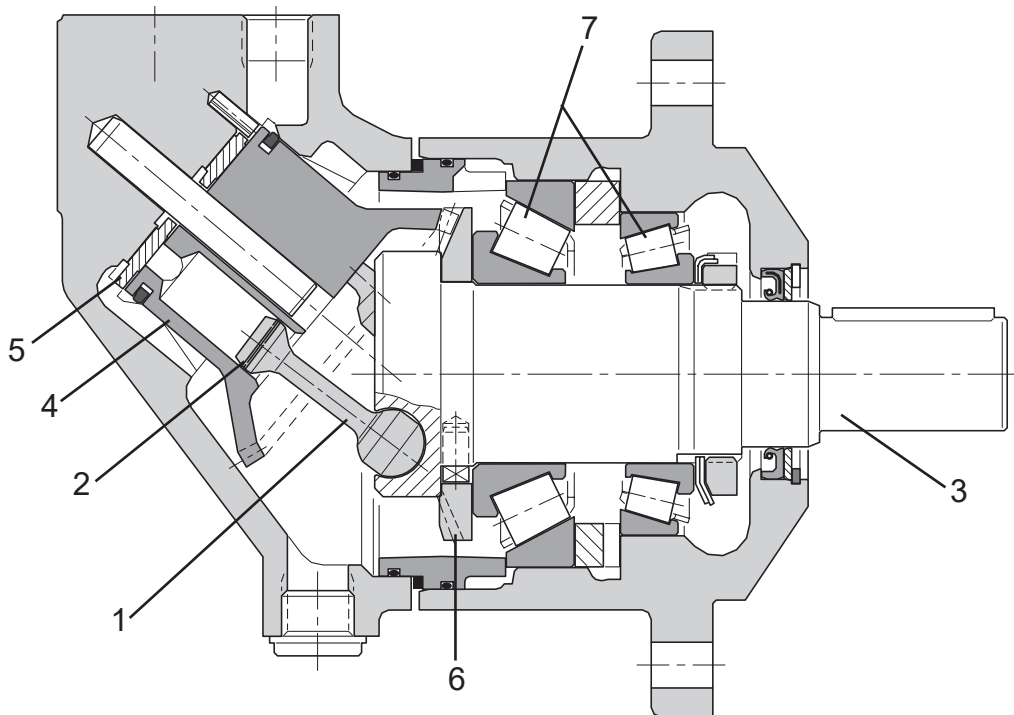

Operational Check

The general condition of the unit can be established by checking the drain flow. Remove the drain line and keep the drain port above a suitable container. Run the unit at 1000 rpm and pressurise the system to 200 bar (3000 psi)

Measure the drain flow for one minute; if it exceeds the maximum figures shown below, the unit is worn or damaged internally and should be replaced or repaired.

Also, check for leakage at the shaft seal and between the bearing and barrel housings.

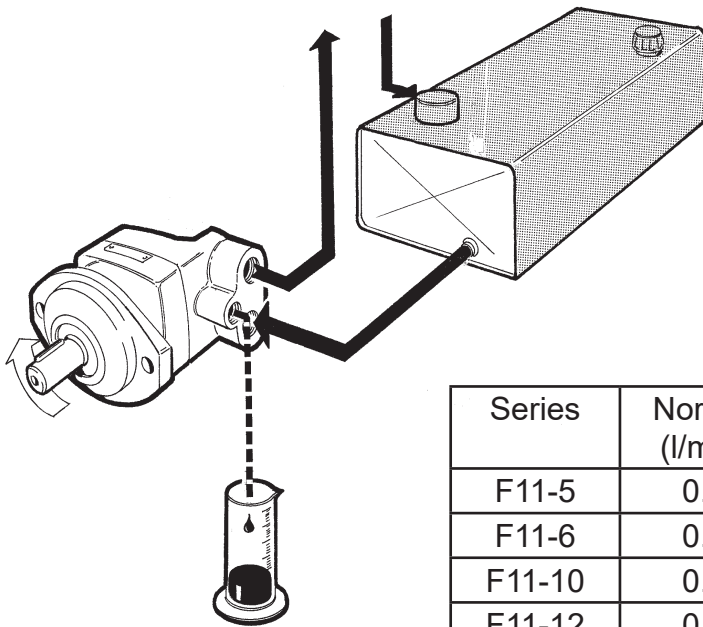

Drain Flow

Series	Normal (l/min)	Normal (gpm, US)	Max (l/min)	Max (gpm, US)
F11-5	0.3	0.08	0.4	0.12
F11-6	0.3	0.08	0.5	0.13
F11-10	0.5	0.13	0.8	0.21
F11-12	0.6	0.17	1.0	0.26
F11-14	0.6	0.15	1.0	0.26
F11-19	0.8	0.20	1.3	0.35

Assembling



1. Place the ring gear on the shaft with the guide pin located against the guide hole.



4. Place the small tapered roller bearing on the shaft as on the picture.



2. Press down the big tapered roller bearing together with the ring gear.



5. Press down the small tapered roller bearing in small steps until correct preload is achieved. Not too tight and no backlash.



3. Place the distance ring on the big tapered roller bearing.



6. Place the lock washer(s) on to the shaft.

Assembling



7. Assemble the round nut and tighten it until one opening is in correct position for the lock washer.

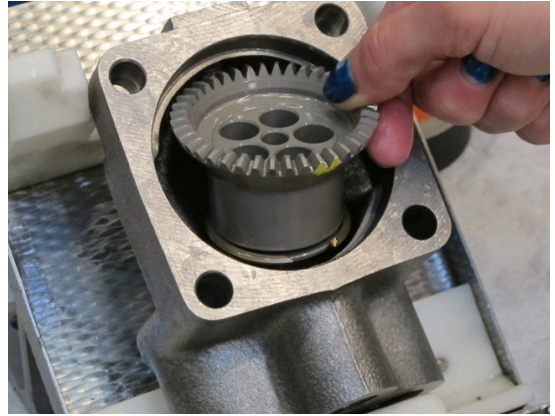

10. Assemble the cylinder barrel.
Instructions on page 11.



8. Secure the round nut as shown in the picture.



11. Assemble the O-rings on the distance ring.



9. Assemble the valve plate. Make sure the slot is in correct position and the valve plate is located as shown in picture.

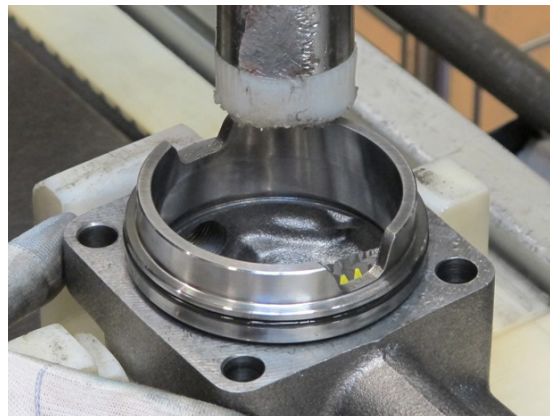

12. Carefully tap down the distance ring to the barrel housing. Lubricate them with oil before assembly.

Assembling



13. Assemble the shims.

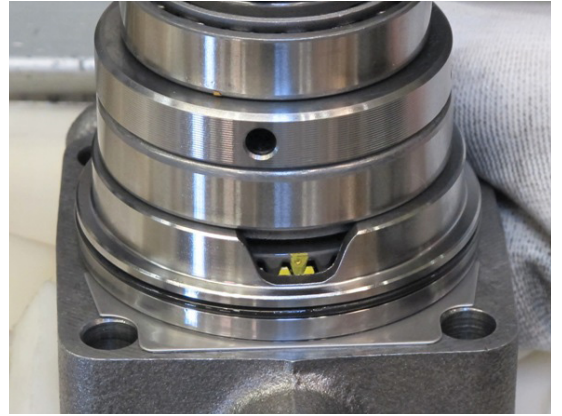

16. Make sure the timing is correct.



14. Assemble the pistons. Lubricate the ball sockets before assembly.

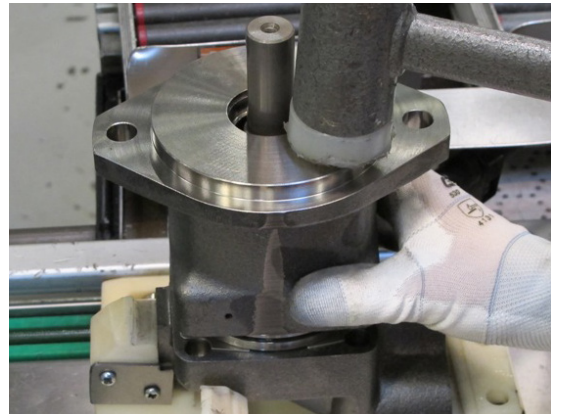

17. Carefully tap down the bearing housing.

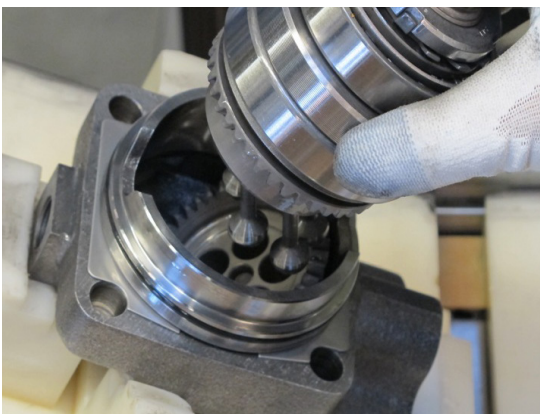

15. Assemble the shaft package with pistons in to the cylinder barrel.



18. Lubricate the sealing surface on the shaft before assembling the shaft seal.

Assembling



19. Carefully push down the shaft seal.

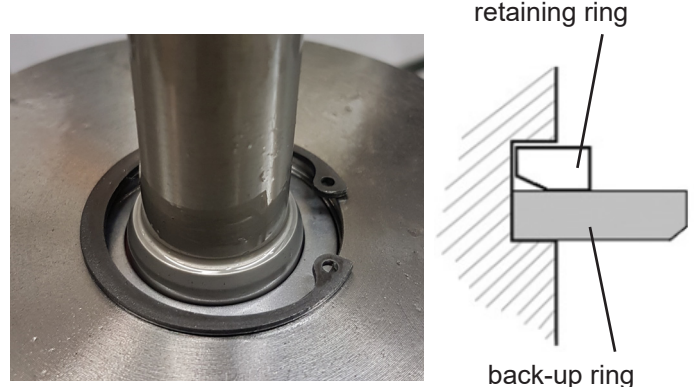

22. Assemble the retaining ring. Make sure the chamfer is downwards.

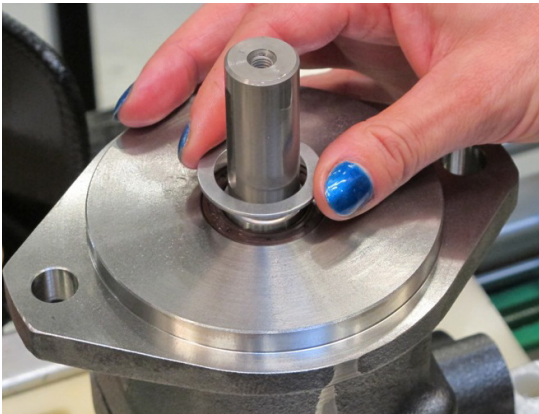

20. Place the support ring with the radius against the dust lip on the shaft seal.

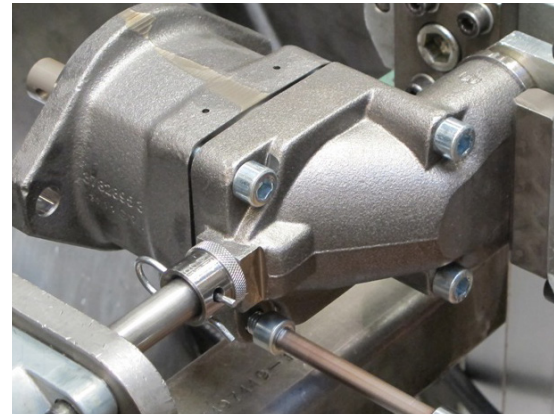

23. Assemble the hexagon screws and torque them to specified value, shown on page 12.



21. Carefully tap down shaft seal and support ring.

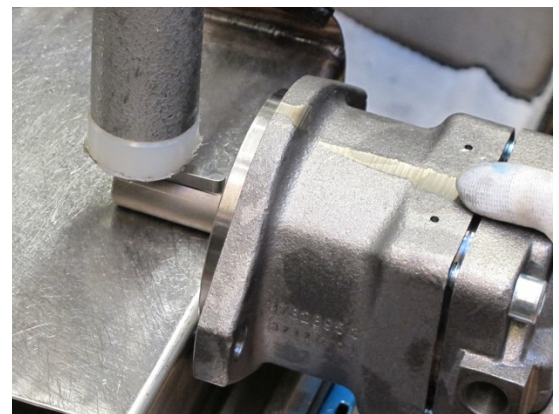

24. Tap down the flat key and turn the shaft at least one revolution. Make sure the back-lash of the gears are correct (see page 12).

Barrel retaining ring



1. Assemble the barrel retaining ring. Note, grooves upwards as on picture.

One groove

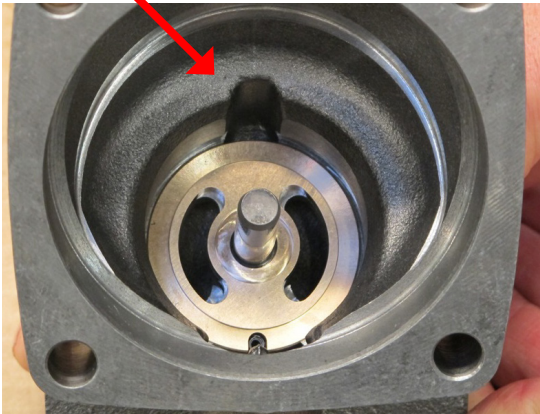

2. When the barrel housing have one groove assemble the cylinder barrel as shown in picture 3.

Two grooves

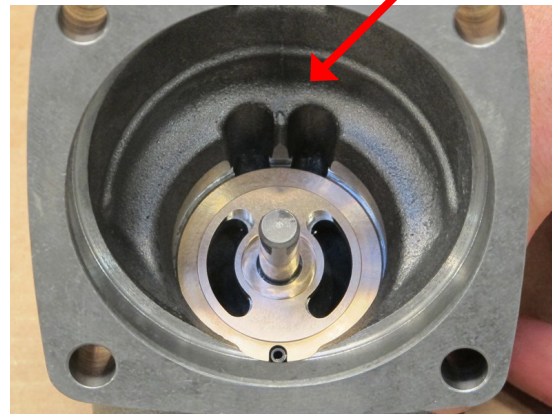

4. When the barrel housing have two grooves assemble the cylinder barrel as shown in picture 5.

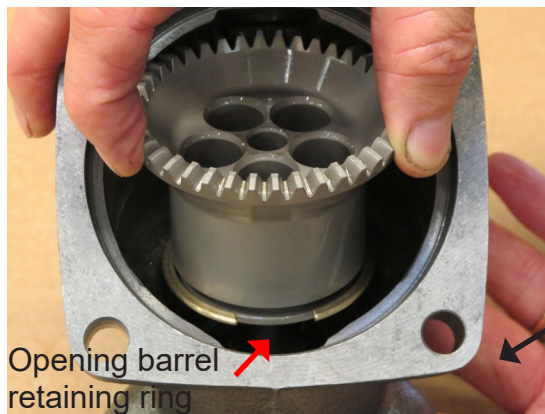

3. Assemble the cylinder barrel as shown in picture.

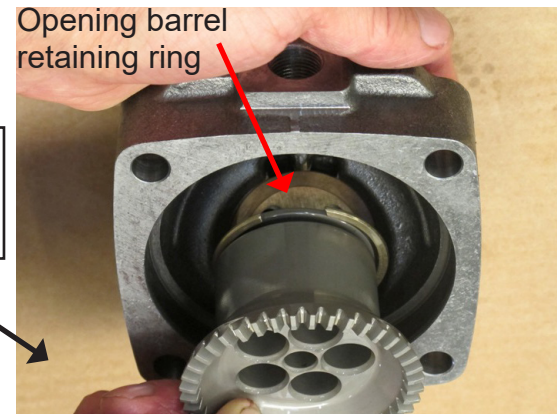

5. Assemble the cylinder barrel as shown in picture.

Torque

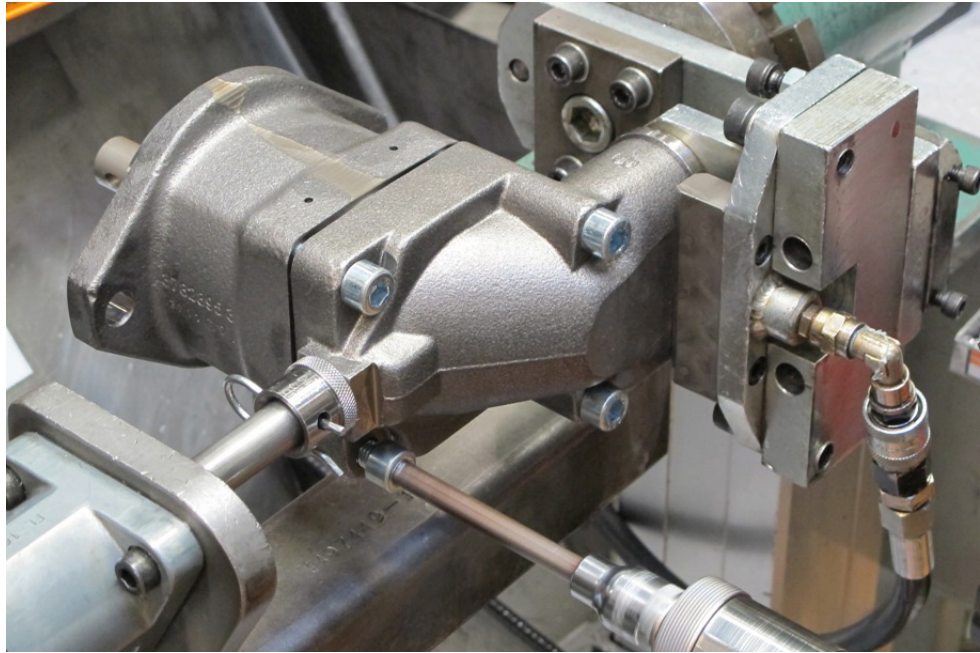

Size	Torque (Nm)	Torque (lbf·ft)
F11-5	24±4	18±3
F11-6	48±8	35±6
F11-10	48±8	35±6
F11-12	48±8	35±6
F11-14	48±8	35±6
F11-19	48±8	35±6

Gear Backlash

F11-5 through F11-19
0.10 - 0.25 mm

Frame size	"R" mm
F11-5	25.0
F11-6	31.3
F11-10	31.3
F11-12	31.3
F11-14	31.3
F11-19	37.5

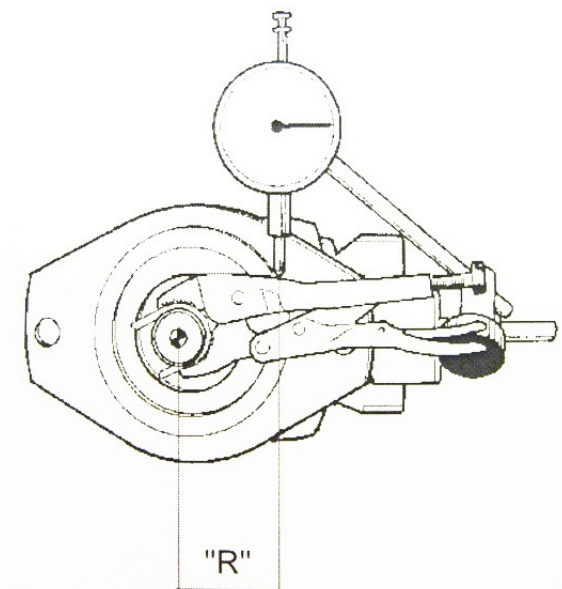

Split View

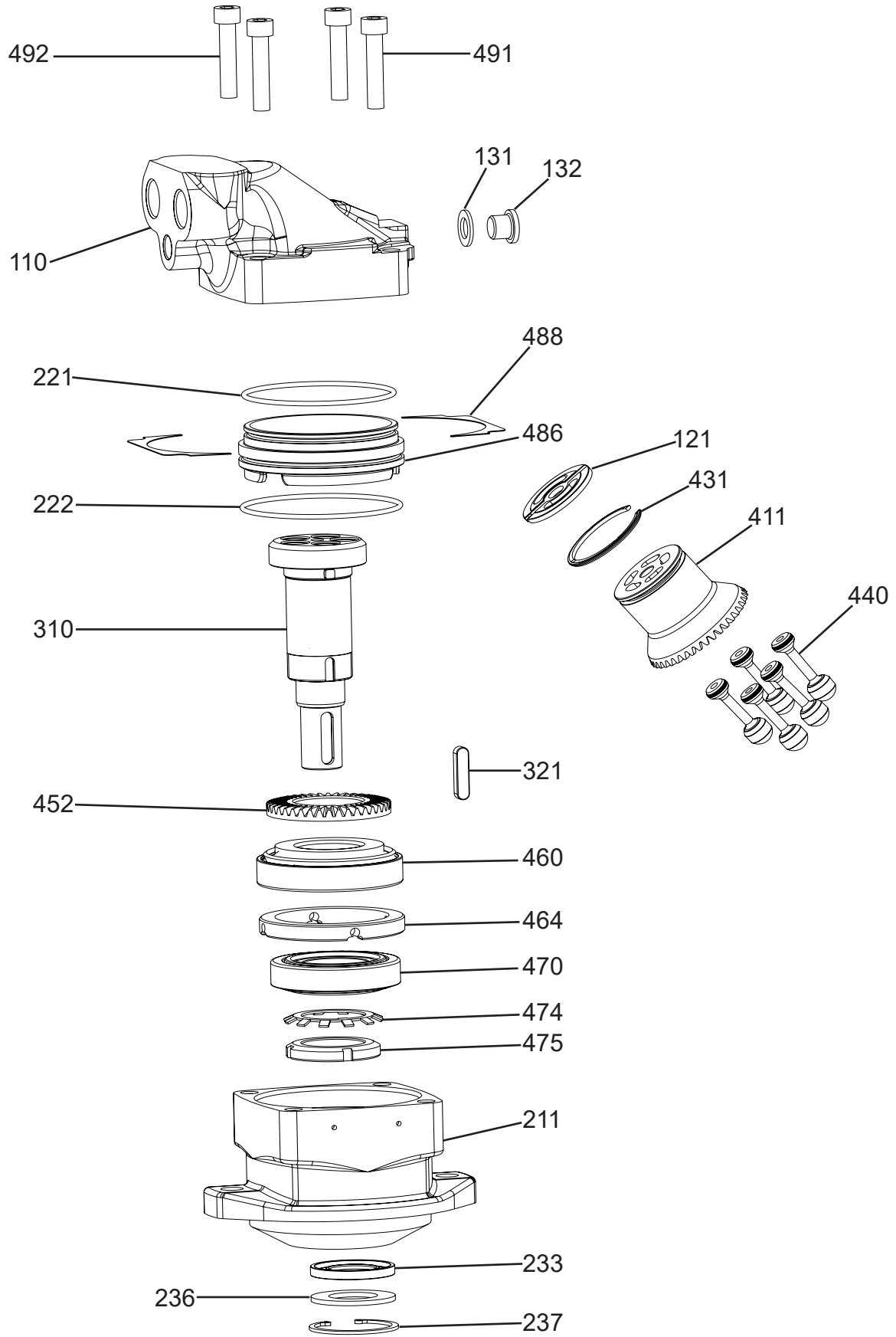

Part Specification

Item	Title	Benämning
110	Barrel Housing	Trumhus
121	Valve Plate	Ventilskiva
131	Seal Washer	Tätbricka
132	Hexagon Plug	Insexpropp
211	Bearing Housing	Lagerhus
221	O-ring	O-ring
222	O-ring	O-ring
233	Shaft Seal	Axeltätning
236	Back-up Ring	Stödbricka
237	Retaining Ring	Spårring
310	Shaft	Axel
321	Flat Key	Plattkil
411	Cylinder Barrel	Cylindertrumma
431	Barrel Retaining Ring	Fästring
440	Piston	Kolv
452	Ring Gear	Kuggkrans
460	Tap Rol Bearing	Koniskt Rullager
464	Spacer Ring	Distansring
470	Tap Rol Bearing	Koniskt Rullager
474	Lock Washer	Låsbricka
475	Round Nut	Rundmutter
486	Guide Spacer	Distanshylsa
488	Shim	Schims
491	Hexagon Screw	Insexskruv
492	Hexagon Screw	Insexskruv

Saw Motor

Right hand rotation shown (CW)

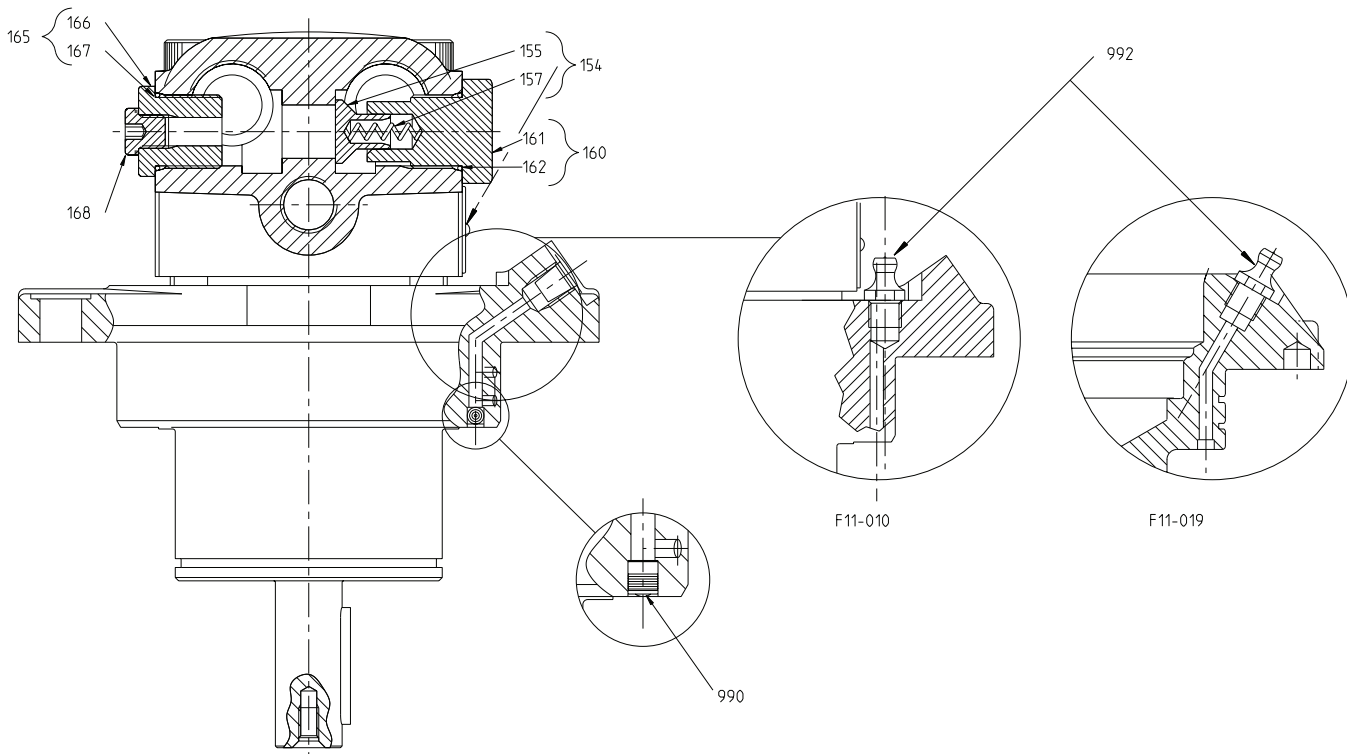

How to change direction of rotation

Move item 154 and 160 to the left side and item 165 and 168 to the right side for left hand rotation (CCW).

Torque

Item	Torque (Nm)	Torque (lbf·ft)
161	100±10	74±7
166	100±10	74±7
168	25±5	18±4
992	9±2	7±1.5

Parts Specification

Item	Title	Benämning
155	Check Valve Cone	Backventilkägla
157	Compression Spring	Tryckfjäder
161	Hex Socket Plug	Sexkantpropp
162	O-ring	O-ring
166	Adapter Nipple	Adaptornippel
167	O-ring	O-ring
168	Hexagon Plug assy	Insexpropp kpl
990	Expanding Plug	Expanderplugg
992	Grease Fitting	Smörjnippel

Valve Plates

Type	Description
M	Bi-directional, motor or pump operation
S	Bi-directional, motor operation, high speed, bi-metal
L	Left hand rotation, pump operation
R	Right hand rotation, pump operation
Q	Bi-directional, motor operation, low noise
H	Bi-directional, motor operation, high pressure
J	Right hand rotation, motor operation, internal drain
G	Left hand rotation, motor operation, internal drain

Note!

The internal drained valve plates G and J is shown from the back side of the valve plate.
From the front, when installed, they look the same as the M valve plate.

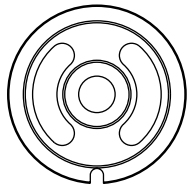

M

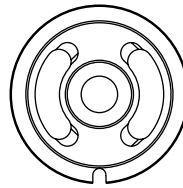

Q

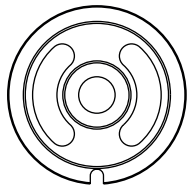

S

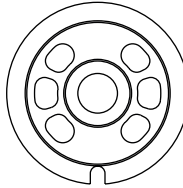

H

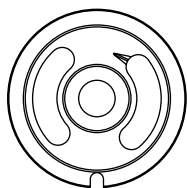

R

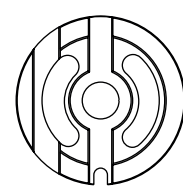

J

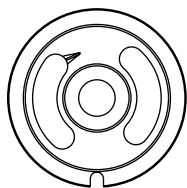

L

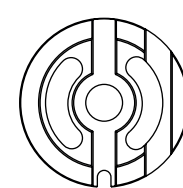

G