

P1-PD Series Medium Pressure Mobile Pumps Product Catalog



ENGINEERING YOUR SUCCESS.

Contents

Contents

General Information & Technical Specs	3
Ordering Information	4
Shaft Technical Data.....	6
Control Options	7
Performance Data	
Typical Pump Outlet Flow	14
Typical Shaft Input Power	16
Typical Shaft Bearing Life	19
Typical Noise Characteristics.....	21
Dimensional Data	
P1/PD 018	25
P1/PD 028	29
P1/PD 045	33
P1/PD 060	37
P1/PD 075 & 085	42
P1/PD 100	47
P1/PD 140	52
Controls	57
Installation Information	63
Conversions & Formulas	64
Offer of Sale	66
Content Index.....	67



Description

- Variable displacement, axial piston pump for open-circuit applications
- Continuous operation at pressures up to 280 bar
- High drive speed models for mobile markets and low noise models for industrial markets
- Quiet and efficient control capability
- Cam bearing design

Benefits

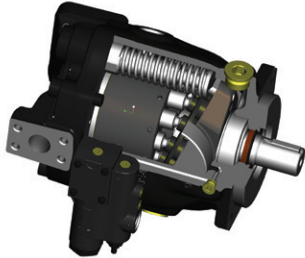

- Compact overall package size
- High power density
- Many different standard control options
- Modular controls for easy conversions
- High operating efficiency for lower power consumption and reduced heat generation
- Elastomer seals that eliminate gaskets and external leakage
- Simple hydraulic controls with “no-leak” adjustments
- Fast and stable compensator response
- SAE and ISO standard mounting flanges and ports
- Long life, roller shaft bearings
- Long life, low friction, hydrostatically balanced swash plate saddle bearings
- Full power through-drive capability
- Multiple case drain ports for various mounting orientations
- Optional minimum and maximum displacement adjustments
- Easy to service

Technical Data

Model	P1/PD 018	P1/PD 028	P1/PD 045	P1/PD 060	P1/PD 075	P1/PD 085	P1/PD 100	P1/PD 140
Maximum Displacement, cm ³ /rev cu.in./rev	18 1.10	28 1.71	45 2.75	60 3.66	75 4.58	85 5.19	100 6.01	140 8.54
Outlet Pressure – Continuous	280 bar (4060 psi)					250 bar (3600 psi)	280 bar (4060 psi)	
Intermittent*	320 bar (4640 psi)					300 bar (4350 psi)	320 bar (4640 psi)	
Peak	350 bar (5075 psi)					320 bar (4600 psi)	350 bar (5075 psi)	
P1 Maximum Speed (1.3 bar abs inlet), rpm	3500	3400	3100	2800	2700	2700	2500	2400
P1 (1.0 bar abs inlet), rpm	3300	3200	2800	2500	2400	2400	2250	2100
P1 (0.8 bar abs inlet), rpm	2900	2900	2400	2200	2100	2100	1900	1800
PD Maximum Speed (1.0 bar abs inlet), rpm	1800							
PD (0.8 bar abs inlet), rpm	1800							
Minimum Speed, rpm	600							
Inlet Pressure – Maximum	11 bar absolute (160 psi)							
Rated	1.0 bar absolute (14.5 psi)							
Minimum	0.8 bar absolute (11.6 psi)							
Case Pressure – Peak, bar	4.0 bar absolute (58 psi) and less than 0.5 bar (7.3 psi) above inlet pressure							
Rated, bar	2.0 bar absolute (29 psi) and less than 0.5 bar (7.3 psi) above inlet pressure							
Fluid Temperature Range, °C °F	-40 to +95 -40 to +203							
Fluid Viscosity – Rated, cSt	7 to 160							
Optimum Range, cSt	14-50 cSt.							
Max. Intermittent, cSt	5000 (for cold starting)							
Min. Intermittent, cSt	5							
Fluid Contamination – Rated, ISO	20/18/14							
Weight – End Port, kg (lb)	13.4 (29.5)	17.7 (39.0)	23 (50)	29 (64)	30 (66)	30 (66)	51 (112)	66 (145)
Side Port, kg (lb)	14.2 (31.3)	18.1 (40.0)	24 (52)	30 (67)	31 (68)	31 (68)	53 (117)	67 (147)
Thru-Drive, kg (lb)	15 (34)	22 (48)	27 (59)	34 (75)	35 (77)	35 (77)	55 (121)	82 (180)
Moment of Inertia kg-mm ²	760	1555	3208	4548	5041	5041	12027	21400
Moment of Inertia Thru-Drive, kg-mm ²	793	1618	3268	4687	5207	5207	12402	22343

*Intermittent is defined as less than 10% of operation time, not exceeding 20 successive seconds.

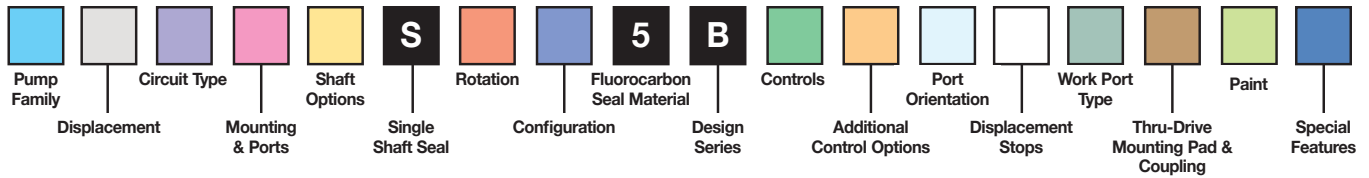

Pump Family	
P1	Mobile
PD	Industrial

Displacement	
018	18cc/rev
028	28cc/rev
045	45cc/rev
060	60cc/rev
075	75cc/rev
085	85cc/rev
100	100cc/rev
140	140cc/rev

Circuit Type	
P	Open Circuit - One Side of Center
X	Open Circuit - Overcenter (45-75, 100-140cc with P, T, S, U controls only)

Mounting & Ports	
S	SAE mount; SAE work & aux ports
A	SAE mount; Metric work ports; BSPP aux ports
M	ISO mount; Metric work & aux ports
B	ISO mount; Metric work ports; BSPP aux ports
C	2-bolt SAE C mount; SAE work & aux ports (60-85cc only)
D	2-bolt SAE C mount; metric work ports; BSPP aux ports (60-85cc only)
J	2-bolt SAE-B mount; SAE work & aux ports (60cc only)
K	2-bolt SAE-B mount; Metric work ports; BSPP aux ports (60cc only)

Shaft Options	
01	SAE Spline
02	SAE Keyed
04	ISO Keyed
06 ¹	SAE Spline (18 & 100cc only)
08	SAE-B 13T Spline (28 & 45cc only)
09	SAE-BB 15T Spline (60cc only)
10	SAE-B 13T Spline (60cc only; Not with thru drive)

¹ 18cc de-rated to 210 bar

Rotation	
R	Clockwise
L	Counterclockwise

Configuration	
M	Mobile (P1)
S	Industrial (PD)
U ²	Universal (45-140cc only)

² Comes with torque limiter ports drilled in the housing

Controls	
C0	Pressure Limiter
L0	Load sensing & pressure limiter
L2	Load sensing with bleed & pressure limiter
AM	Remote pressure limiter
AN	Remote pressure limiter with D03 interface
AE	Prop. Pressure limiter (Min default - 12VDC)
AF	Prop. Pressure limiter (Min default - 24VDC)
AG ³	Prop. Pressure limiter (Max default - 24VDC)
AH ³	Prop. Pressure limiter (Max default - 12VDC)

Electronic Displacement Controls	
P0	Min default; No Pmax override; 12 VDC
PM	Min default; No Pmax override; 24 VDC
T0	Max default; No Pmax override; 12 VDC
TM	Max default; No Pmax override; 24 VDC
S0	Min default; Pmax override; 12 VDC
SM	Min default; Pmax override; 24 VDC
U0	Max default; Pmax override; 12 VDC
UM	Max default; Pmax override; 24 VDC

³ Requires application review. Consult factory.

Additional Control Options	
0	No other options
2	Cam sensor (mandatory with P, T, S, U controls)
3 ⁴	Unload Valve - 12VDC (C0 or L0 control only)
6 ⁴	Unload Valve - 24VDC (C0 or L0 control only)
4	210 bar pressure limit (AG or AH control only)
7	280 bar pressure limit (AG or AH control only)
T	Torque Limiter (45-140cc only; L0, AM, AN control only)

⁴ Available on 28-140cc only

Port Orientation	
E	End Ports
S	Side Ports (60-140cc only)
R	Side Ports with ripple chamber (18-45cc only)
T	Side Ports with thru-drive

Displacement Stops ⁵	
0	None
1	Adjustable maximum stop
2	Adjustable minimum stop
3	Adjustable maximum & minimum stop

⁵ Not standard with thru drive. Contact factory for approval.

Work Port Type	
0	Flanged (Not with 18cc "E" or "R" ports)
2 ⁶	Threaded (18-60cc only)

⁶ On 60cc, only with SAE end ports

Thru-Drive Designation Description	
0	None
A	SAE 82-2 (A), 9T coupling
H	SAE 82-2 (A), 11T coupling
B	SAE 101-2 (B), 13T coupling (28-140cc only)
Q	SAE 101-2 (B), 15T coupling (28-140cc only)
C	SAE 127-4 (C), 14T coupling (60cc only) SAE 127-2/4 (C), 14T coupling (75-140cc only)
N	SAE 127-4 (C), 17T coupling (100 & 140cc only)
D	SAE 152-4 (D), 13T coupling (140cc only)

Paint	
00	No Paint
PB	Black Paint

Special Features	
00	Standard
M2	Special Designation

Mounting Designation Descriptions

Code	Standard	18	28	45	60	75 & 85	100	140
S & A	SAE J744	SAE-A 2-Bolt	SAE-B 2-Bolt	SAE-B 2-Bolt	SAE-C 4-Bolt	SAE-C 4-Bolt	SAE-C 4-Bolt	SAE-D 4-Bolt
M & B	ISO 3019/2	ISO 80mm 2-Bolt	ISO 100mm 2-Bolt	ISO 100mm 2-Bolt	ISO 125mm 4-Bolt	ISO 125mm 4-Bolt	ISO 125mm 4-Bolt	ISO 180mm 4-Bolt
C & D	SAE J744	N/A	N/A	N/A	SAE-C 2-Bolt	SAE-C 2-Bolt	N/A	N/A
J & K	SAE J744	N/A	N/A	N/A	SAE-B 2-Bolt	N/A	N/A	N/A

Shaft Descriptions

Code	18	28	45	60	75 & 85	100	140
01	SAE 11T spline	SAE-BB 15T spline	SAE-BB 15T spline	SAE-C 14T spline	SAE-C 14T spline	SAE-CC 17T spline	SAE-D 13T spline
02	SAE 19mm keyed	SAE-BB keyed	SAE-BB keyed	SAE-C keyed	SAE-C keyed	SAE-CC keyed	SAE-D keyed
04	ISO 20mm keyed	ISO 25mm keyed	ISO 25mm keyed	ISO 32mm keyed	ISO 32mm keyed	ISO 40mm keyed	DIN 50mm keyed
06	SAE-A 9T spline	N/A	N/A	N/A	N/A	SAE-C 14T spline	N/A
08	N/A	SAE-B 13T spline	SAE-B 13T spline	N/A	N/A	N/A	N/A
09	N/A	N/A	N/A	SAE-BB 15T spline	N/A	N/A	N/A
10	N/A	N/A	N/A	SAE-B 13T spline	N/A	N/A	N/A

Maximum Flange Moment Ratings

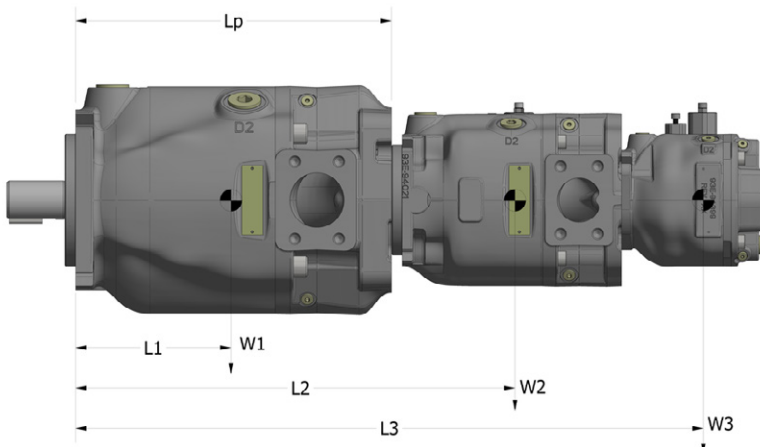

$$\text{Moment } M = (L1*W1+L2*W2+L3*W3...) \div 102$$

Measurement	Units	P1/PD Displacement							
		18	28	45	60	75	85	100	140
Maximum Static Moment	Nm	500	650	1000	1200	1600	1600	2200	3200
Maximum Dynamic Moment (at 10g acceleration)	Nm	50	65	100	120	160	160	220	320
Distance L1 (no thru drive)	mm	73	93	107	110	119	119	154	154
Distance L1 (thru drive)	mm	104	113	115	123	134	134	179	185
Distance Lp	mm	199	233	229	253	264	264	340	364

Shaft Torque Ratings

		Units	18 (1.1)	28 (1.71)	45 (2.75)	60 (3.66)	75 (4.58)	85 (5.19)	100 (6.1)	140 (8.54)
Maximum Input shaft torque	01	Nm	134	337	337	641	641	641	1217	1701
		ft.lbs	99	249	249	473	473	473	898	1255
	02	Nm	130	357	357	559	559	559	1134	1732
		ft.lbs	96	264	264	413	413	413	837	1278
	04	Nm	113	337	337	576	576	576	1157	1708
		ft.lbs	84	249	249	425	425	425	854	1260
	06	Nm	58	N/A	N/A	N/A	N/A	N/A	641	N/A
		ft.lbs	43						473	
	08	Nm	N/A	209	209	N/A	N/A	N/A	N/A	N/A
		ft.lbs		155	155					
	09	Nm	N/A	N/A	N/A	337	N/A	N/A	N/A	N/A
		ft.lbs				249				
	10	Nm	N/A	N/A	N/A	209	N/A	N/A	N/A	N/A
		ft.lbs				155				
Maximum through-drive shaft torque		Nm	134	210	293	318	329	329	538	760
		ft.lbs	99	155	217	235	243	243	397	561

Radial and Axial Shaft Load Ratings

Radial Load Diagram

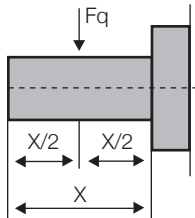

Axial Load Diagram

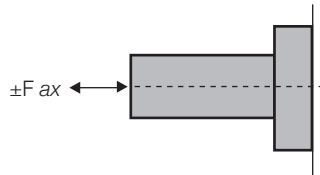

		Maximum Allowable Shaft Load								
		018	028	045	060	075	085	100	140	
Radial Force (At X/2)	N	700	1,000	1,500	1,800	1,900	1,900	2,300	2,600	
	lbf	160	229	343	411	434	434	526	594	
Axial Force	N	1,900	1,900	2,500	2,300	2,300	2,300	3,100	4,200	
	lbf	434	434	571	526	526	526	709	960	

Shaft Rotational Stiffness

Shaft Designation	Units	018		028		045		060		075/085		100		140	
		NRD	RD	NRD	RD	NRD	RD	NRD	RD	NRD	RD	NRD	RD	NRD	RD
01	ft-lb/Rad	4,332	3,475	7,712	6,458	11,681	10,540	18,198	15,397	20,615	16,838	31,080	25,479	47,819	43,970
	Nm/Rad	5,848	4,691	10,411	8,718	15,769	14,229	24,567	20,786	27,830	22,731	41,958	34,397	64,556	59,360
02	ft-lb/Rad	5,082	4,363	7,317	7,293	11,040	6,179	17,828	14,905	16,061	15,661	28,607	23,793	48,994	40,954
	Nm/Rad	6,861	5,890	9,878	9,846	14,904	8,342	24,068	20,122	21,682	21,142	38,619	32,121	66,142	55,288
04	ft-lb/Rad	4,468	3,903	7,011	5,958	9,362	8,715	16,771	14,006	14,994	14,646	25,529	21,625	53,685	44,181
	Nm/Rad	6,032	5,269	9,465	8,043	12,639	11,765	22,641	18,908	20,242	19,772	34,464	29,194	72,475	59,644
06	ft-lb/Rad	2,972	2,846	N/A		N/A		N/A		N/A		26,806	22,533	N/A	
	Nm/Rad	4,012	3,842	N/A		N/A		N/A		N/A		36,188	30,420	N/A	
08	ft-lb/Rad	5,699	5,044	7,320	6,180	10,124	9,255	N/A		N/A		N/A		N/A	
	Nm/Rad	7,694	6,809	9,882	8,343	13,667	12,494	N/A		N/A		N/A		N/A	
09	ft-lb/Rad	N/A		N/A		N/A		16,615	13,370	N/A		N/A		N/A	
	Nm/Rad	N/A		N/A		N/A		22,430	18,050	N/A		N/A		N/A	
10	ft-lb/Rad	N/A		N/A		N/A		11,696	10,472	N/A		N/A		N/A	
	Nm/Rad	N/A		N/A		N/A		15,790	14,137	N/A		N/A		N/A	

NRD = No rear thru drive; RD = Rear thru drive

Control Option “C”

Pressure Limiter

Adjustment Range = 26-280 bar (380-4060 psi)

The "C0" pressure limiter control is used to limit the maximum system pressure. The control acts such that full pump displacement is achieved unless the system valve restricts the output flow or the load pressure reaches the maximum setting of the control. If pump flow is restricted by the system valve, the pump will provide only the flow demanded, but at the maximum pressure setting of the compensator control. If the outlet flow is completely blocked, the pump will destroke to zero displacement and maintain the pressure at the setting of the compensator spring.

Control Option “L”

Load Sensing and Pressure Limiter

Pressure Limiter Adjustment Range = 26-280 bar (380-4060 psi)
Differential Adjustment Range = 10-40 bar (150-580 psi)

The "L0" and "L2" controls feature load sensing and maximum pressure compensation. A load sense line that comes from downstream of the main system throttling valve is connected to the "X" port on the control. This control matches pump flow and pressure to system demands by maintaining a constant pressure drop across the main system throttling valve, thus reducing horsepower losses. The pump automatically adjusts for changes in drive speed and load pressures. Choose the "L2" option if bleeding the load sense line at the pump is desired.

pressure limiter control

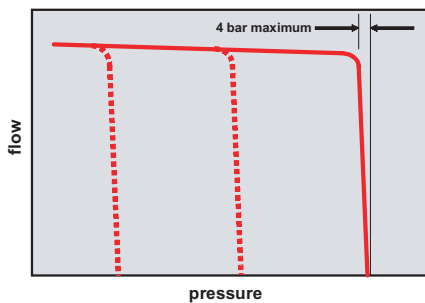

pressure

load sensing and pressure limiter control

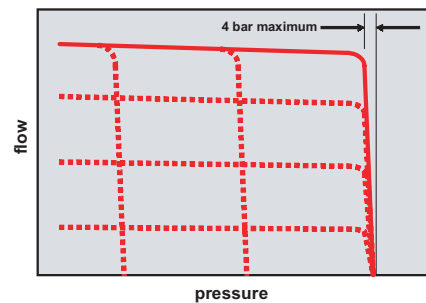

pressure

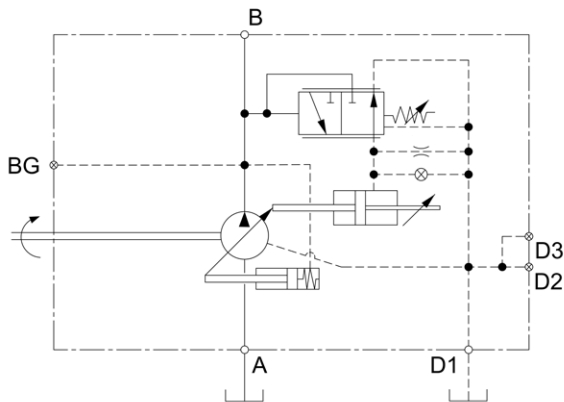

C0 Schematic

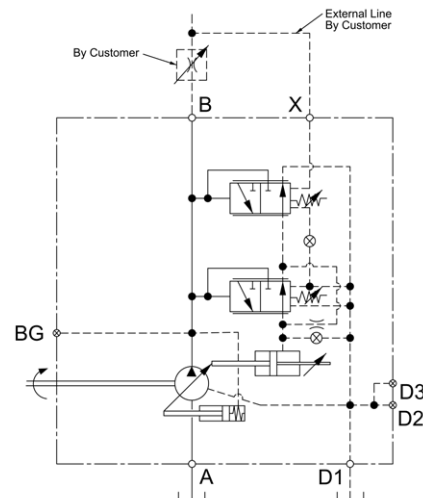

L0 Schematic

Control Description	Pump Operating Condition	Typical Control Response Time (ms)						
		018	028	045	060	075/085	100	140
"C" Pressure Limiter	Maximum Displacement to Zero	25	25	25	37	21	26	30
	Zero Displacement to Maximum	80	80	106	119	89	108	125
"L" Load Sensing	Maximum Displacement to Zero	40	40	30	54	40	43	45
	Zero Displacement to Maximum	70	70	120	186	97	189	280

* Based on NFPA testing standards

**Control Options “AM”
Remote Operated Pressure Limiter**

The "AM" control allows the pump pressure compensator setting to be adjusted from a remote relief valve that is connected to the "X" port on the control. The control acts such that full pump displacement is achieved unless the system valve restricts the output flow or the load pressure reaches the maximum setting of the control. If pump flow is restricted by the system valve, the pump will provide only the flow demanded, but at the maximum pressure setting of the compensator control. If the outlet flow is completely blocked, the pump will destroke to zero displacement and maintain the pressure at the setting of the remote relief valve.

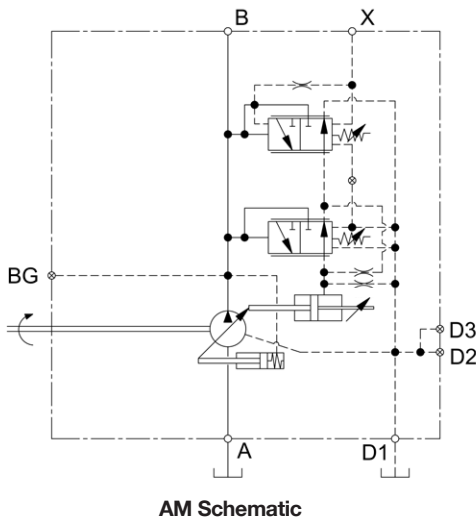
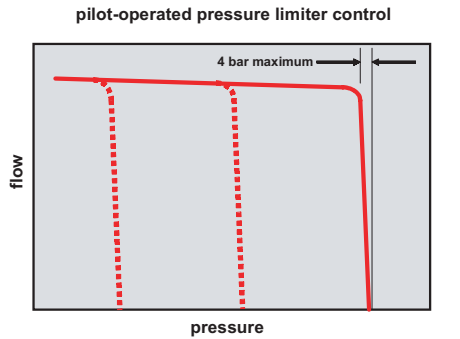

**Control Option “AN”
Pilot Operated Control with ISO 4401 NG6
Interface for Customer Added Pressure Limiter**

The "AN" control is a standard pressure compensator, but with a NG6 (D03) valve interface. It is the same as the "AM" control, but with the addition of an adapter block mounted between the pump housing and control to provide the NG6 (D03) interface. This allows a directional valve or proportional relief valve to be mounted directly on the pump to achieve a variety of pressure control circuits.

Caution: Pumps shipped with the “AN” control need to have a valve mounted to the NG6 interface for operation. This is not a functional control as shipped.

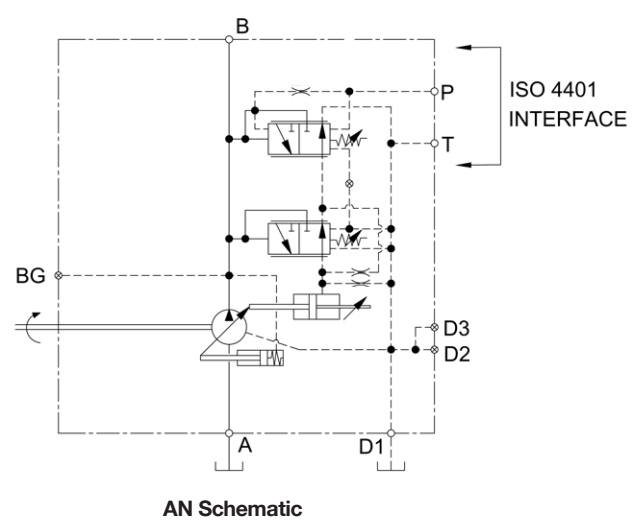
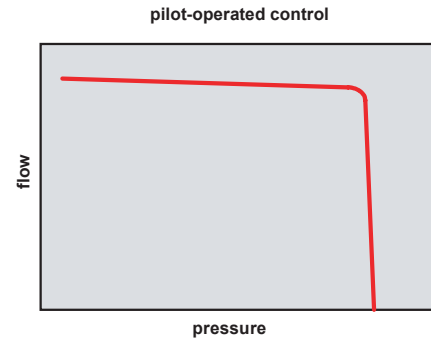

		Typical Control Response Time (ms)						
Control Description	Pump Operating Condition	018	028	045	060	075/085	100	140
“A” Pilot Operated Control	Maximum Displacement to Zero	25	25	46	43	37	39	40
	Zero Displacement to Maximum	80	80	131	125	115	123	130

* Based on NFPA testing standards



Control Options “AMT,” “ANT,” and “LOT”

Torque Limiting Controls: (45-140cc only)

AMT = Remote pressure limiting with torque limiting

ANT = Pilot operated pressure limiting with torque limiting

LOT = Load sense & pressure limiting with torque limiting

These controls provide the benefit of pressure limiting control, plus the ability to limit the input torque when the power available from the prime mover is limited; or when the application power demand has both high flow/low pressure and low flow/high pressure operating conditions.

“AMT” & “ANT” Control

The “AMT” and “ANT” combine the pilot pressure limiter function with a torque limiting function. On the “AMT” control, the pressure limiter function is controlled remotely by connecting an external relief valve to the “X” port. On the “ANT” control, the pilot relief valve is mounted directly on the pump via the NG6 interface on the control block. Once the torque limiter setting is reached, the pump will destroke as pressure continues to rise in order to maintain the same input torque. Once the pressure limiter setting is reached, the pump will destroke to limit the system pressure.

Caution: The ANT control will not function without a valve mounted on the NG6 interface.

“LOT” Control

The “LOT” combines the functions of a pressure limiter, load sense and torque limiter control. The pressure limiter function limits the maximum pump outlet pressure. The load sense control function requires the “X” port to be connected to the highest load pressure via a load sense signal line. The control will match pump output flow and pressure to the system demand, thus minimizing horsepower losses. The pump will operate in a load sense mode until the torque limiter setting is reached, and then the pump will maintain the input torque at the pre-selected setting. If the system pressure reaches the pressure compensator setting, then the pump flow will be lowered to the level needed to maintain the maximum pressure setting.

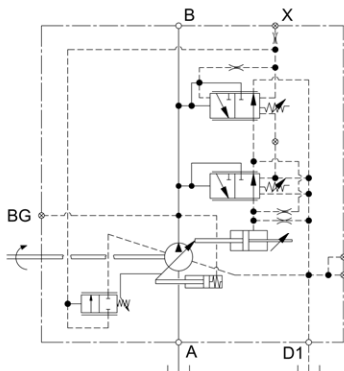

AMT Torque Limiter

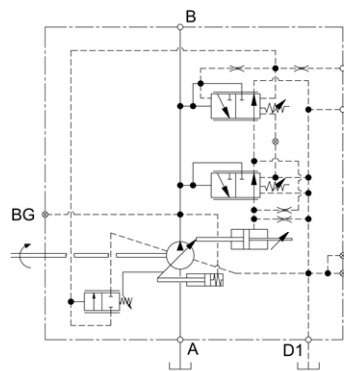

ANT Torque Limiter

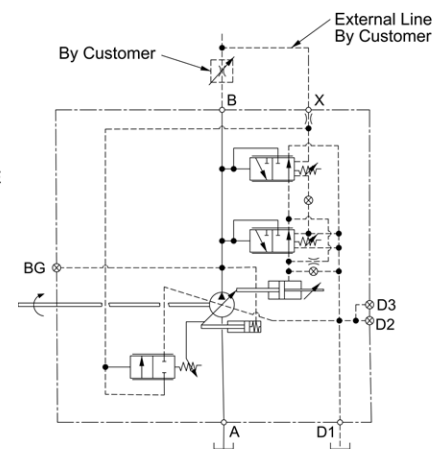

LOT Torque Limiter

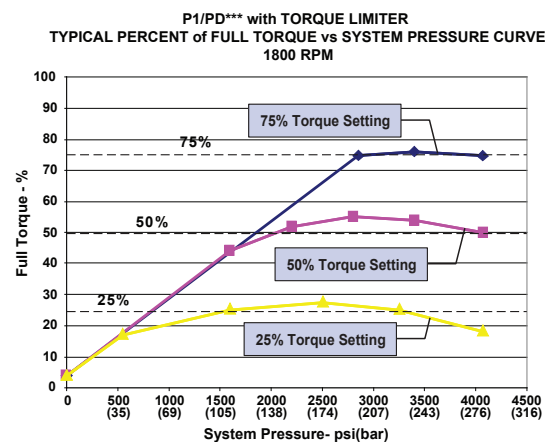
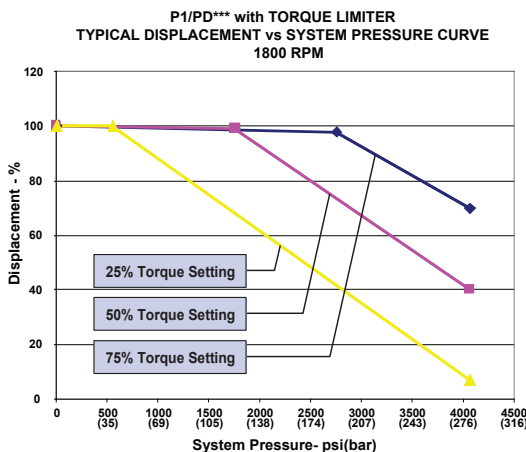

Control Options “AE” and “AF”

Electronic Proportional Pressure Limiting with Mechanical Pressure Limiter

Minimum Pressure Default

AE = 12 VDC Solenoid

AF = 24 VDC Solenoid

This control is the same as the AN control, but with the proportional relief valve included. It allows the pump pressure compensator setting to be adjusted by an on-board 4VP0150G24B1C1 (24V) or RE06M35W2N1KWXG087 (12V) proportional, electronic relief valve. The control acts such that full pump displacement is achieved unless the system pressure reaches the setting of the proportional relief valve or the mechanical pressure limiter. If pump flow is restricted by the system, the pump will provide only the flow demanded, but at the pressure setting of the proportional or mechanical control. If the outlet flow is completely blocked, the pump will destroke to zero displacement and maintain the pressure at the setting of the control.

The proportional relief valve defaults to minimum displacement, so if no current is going to relief valve, then the pump goes to minimum displacement at a low pressure stand-by condition. Furthermore, as current to the proportional relief valve increases, the pressure setting of proportional relief valve increases.

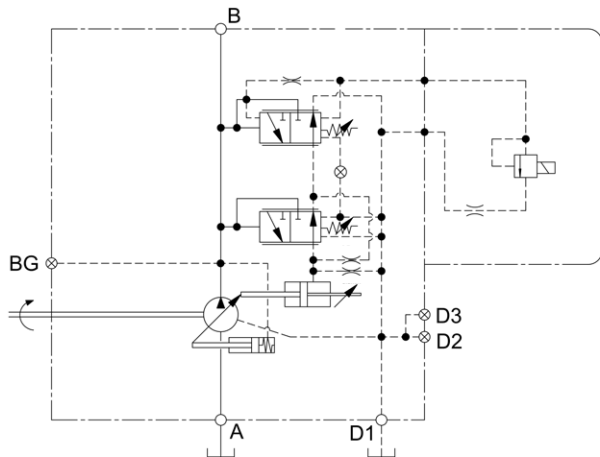

Electric Characteristics		
	RE06	4VP01
Voltage	12VDC	24VDC
Coil Resistance	4 Ohms	25 Ohms
Max current	2.3 A	800mA
Connector	DIN 43650	Plug-in per ISO 4400
Protection Class	IP65	IP65

Note: The pressure relief valve has a command range up to 350 bar, but P1/PD pump is rated to 280 bar continuous pressure.

The following are options to drive the proportional valve on the AE or AF pump:

Parker Part#	Description
027-22071-0	Dual Driver Module (12/24V)
027-22067-0	Plug-Top-Driver 12V (0-10V command)
027-22066-0	Plug-Top-Driver 24V (0-10V command)

Note: Consult Factory for more driver options and information.

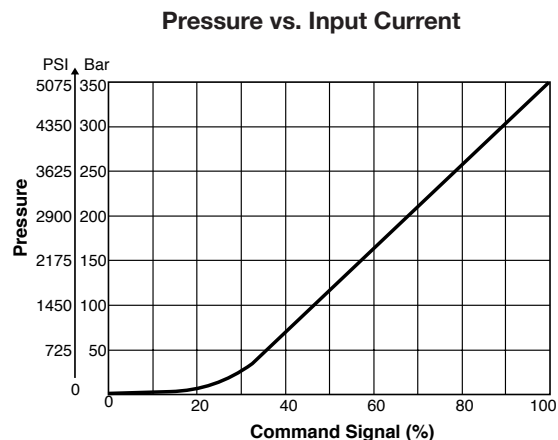
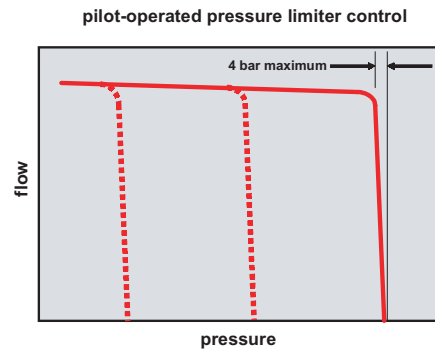

Control Options “C03,” “C06,” “L03,” “L06”

Electronic Unload/Cold Start

- C03 = Pressure limiting with 12VDC unload valve
- C06 = Pressure limiting with 24VDC unload valve
- L03 = Load sense & pressure limiting with 12VDC unload valve
- L06 = Load sense & pressure limiting with 24VDC unload valve

This control contains a cartridge valve that is integrated into the pump control to unload the pump into a low pressure stand-by condition in order to reduce the torque required to turn the pump. This control is often used in cold start conditions when the hydraulic fluid is very cold and viscous. The high fluid viscosity causes the pump to require more torque when initially starting, so this option can be used to de-stroke the pump upon start-up in order to reduce the torque load on the engine to prevent it from stalling.

“LOADED” CONDITION

“C03” & “C06” Controls - Pressure limiting with unload function

When the unload valve is in the spring position (de-energized), the pump is “loaded”. This means the valve sends system pressure to the spring side of the differential spool, so that pressure on both sides of that spool is equal. Therefore, the spring setting prevents the differential spool from moving, so only the Pmax spool is active. Thus the control behaves just like a standard pressure limiting control.

“L03” & “L06” Controls - Load sensing & pressure limiting with unload function

When the unload valve is in the spring position (de-energized), the pump is “loaded”. The load sense function requires the signal port be connected to load pressure, and the valve sends the load pressure to the spring side of the differential spool, so that a pressure differential is created between the spring side of the spool and the system side allowing the control to function like a standard load sensing control.

“UNLOADED” CONDITION

When the unload valve is in the energizes, the pump is “unloaded”. This means the valve dumps the pressure on the spring side of the differential spool, activating that spool which sends pressure to the control piston of the pump and allows the pump to de-stroke into a low pressure stand-by condition.

C0* Pressure Compensator Control with Unloading Valve

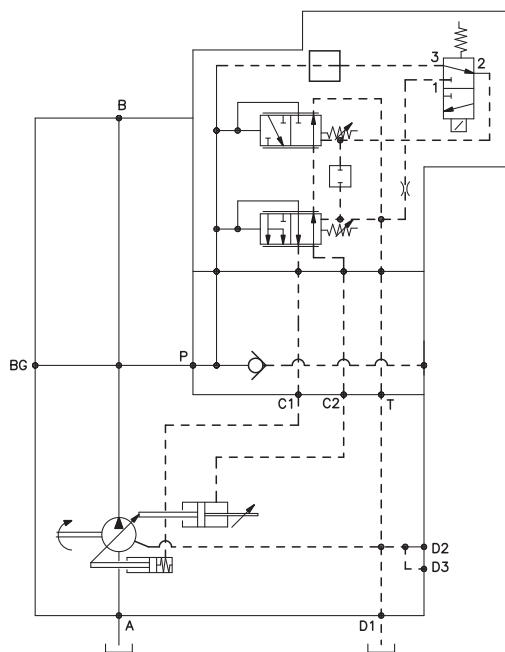

L0* Load Sense Control with Unloading Valve

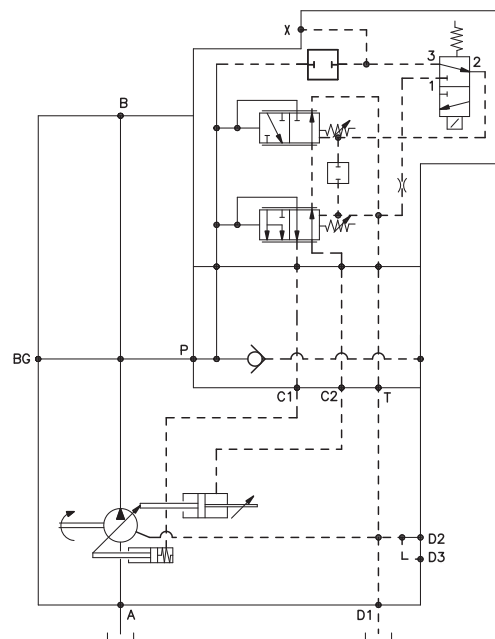

Control Options “AG” and “AH”

Electronic Proportional Pressure Limiting with Mechanical Pressure Limiter

Full Pressure Default

AG = 24 VDC

AH = 12 VDC

This control contains a Parker AP02B2YR35ALV proportional electronic pressure relief cartridge valve and mechanical pressure limiter that are integrated into the pump control to limit the maximum pressure of the pump either electronically or mechanically.

The control acts such that full pump displacement is achieved until the system pressure reaches the setting of the proportional relief or mechanical pressure limiter. If pump flow is restricted by the system, the pump will provide only the flow demanded, but at the pressure of the control setting. If the outlet flow is blocked, the pump will de-stroke to minimum displacement and maintain the pressure of the control setting.

The proportional relief valve defaults to maximum displacement, so if no current is going to the valve then the pump goes to full displacement until the pressure setting of the mechanical pressure limiter is reached. Furthermore, as current to the proportional relief valve is increased, the pressure setting of the proportional relief decreases. This type of can is often used in fan drive applications so that maximum cooling is achieved in the event of control signal loss.

Note: For the "A*7" option, the pressure relief valve has a command range up to 350 bar, but P1/PD pump is rated to 280 bar continuous pressure.

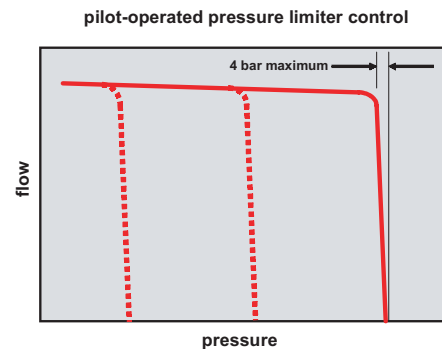
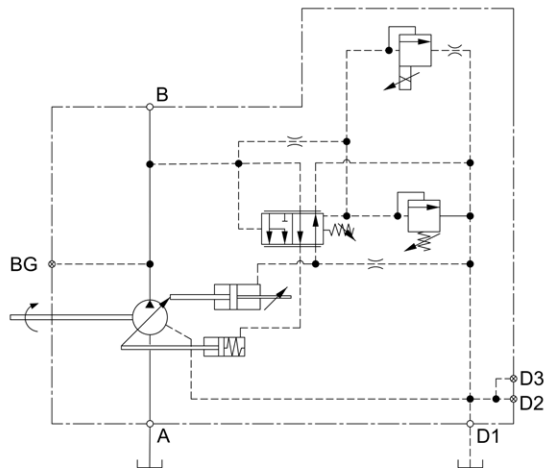

Electric Characteristics	
Coil Power	28 W*
Coil Resistance	5.1 Ohms (12 VDC) 20.6 Ohms (24 VDC)
Max current	2.33 A (12 VDC) 1.17 A (24 VDC)
PWM Signal	100-250 Hz (recommended)
Hysteresis	< 10%
Connection	Deutsch DT04-2P (IP 67)

*18 W coils available on request

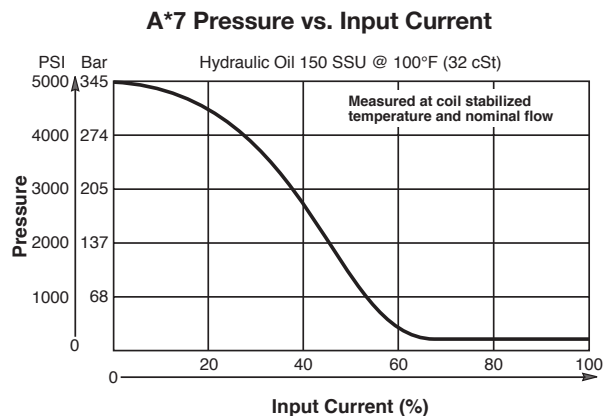

Control Options “P,” “T,” “S,” “U”

Electronic Proportional Displacement & Pressure Limiting

P = Min displacement default*

T = Max displacement default*

S = Min displacement default and hydromechanical pressure limiter

U = Max displacement default and hydromechanical pressure limiter

* Pumps without pressure limiter should be designed in a circuit with other means of pressure limitation.

The control uses the D1FB electronic proportional valve from Parker’s Hydraulic Valve Division to provide the precise flow specified per a displacement input command and maintain that flow level until a new displacement command level is received, or until the pressure command overrides to limit system pressure.

The holding current can vary from pump to pump, but is typically between 1.3-1.6 Amps for the 12V valve and 700-800 mA for the 24V valve.

A minimum of 25 bar servo pressure is required to control the pump. To control the pump at system pressure below 25 bar, either a sequence valve in the pressure line or an external servo source is required. Without adequate servo pressure, the pump is biased on stroke.

The mechanical pressure limiter will override the electronic inputs and limit pump outlet pressure to the preset level.

Using electronic control, the pump can be used in overcenter condition. (Energy recovery is one example of application for this.)

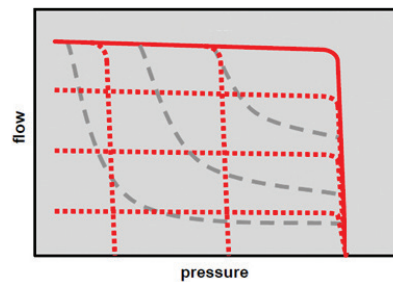

Electronic Proportional Valve Information		
Parameter	12 VDC	24 VDC
Resistance @ 20 C	4.4 Ohm	18.6 Ohm
Max Current	2.7 A	1.3 A
PWM Signal	100-250 Hz	
Typical Hysteresis*	<2%	
Connector	Deutsch DT04-2P	
Protection Class	IP66	

* Good results found with superimposed dither amplitude of +/- 200 mA for 12V valve and +/- 100 mA for 24V valve

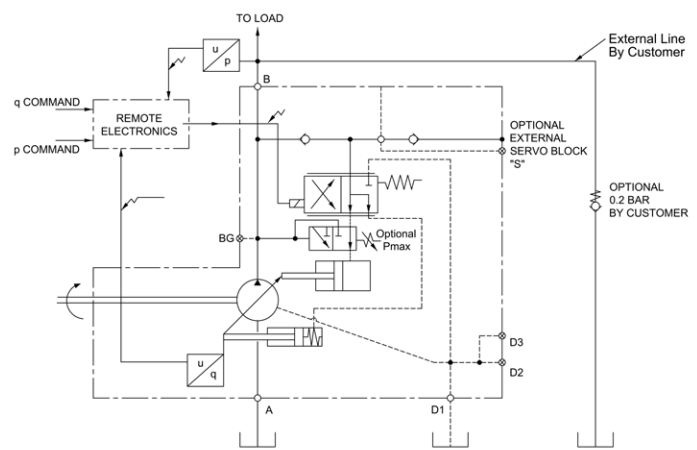

"S" Control Schematic

Typical Control Response Times

Displacement (cc)	Response time (ms)						
	18	28	45	60	75/85	100	140
Max to zero	40	40	43	63	96	101	109
Zero to max	35	35	36	52	72	77	84

Displacement Sensor Wiring

DT04-3P Deutsch Connector		
Wire color	Pin #	Signal
Red	A	+5VDC
Black	B	0VDC
Blue	C	0 to 5VDC

For CW: Full stroke = 0.56VDC, Zero stroke = 2.5VDC, 100% overcenter = 4.44VDC
 For CCW: Full stroke = 4.44VDC, Zero stroke = 2.5VDC, 100% overcenter = 0.56VDC

P1/PD Series Typical Pump Outlet Flow

PD Maximum Speed Rating = 1800 rpm

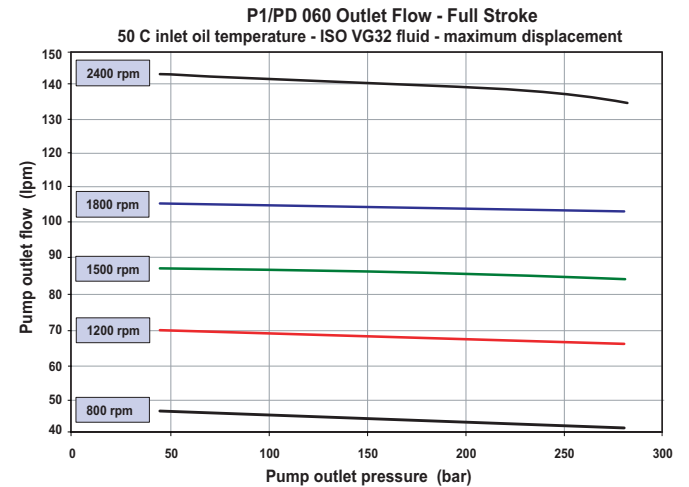
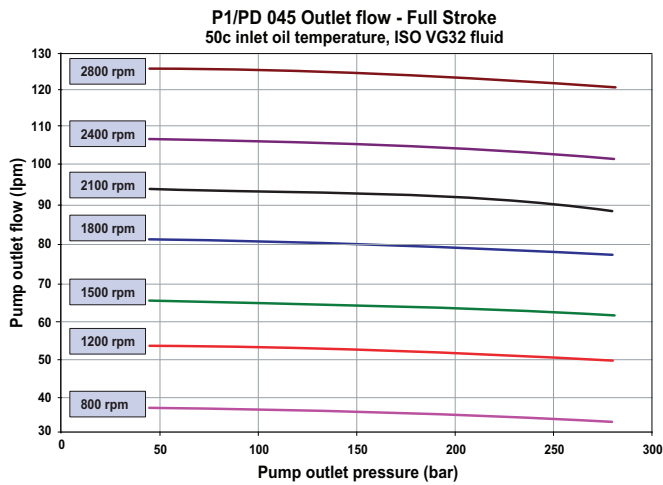
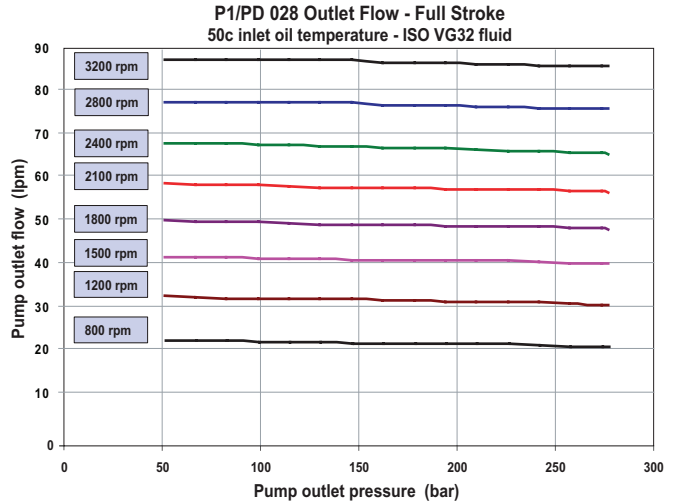
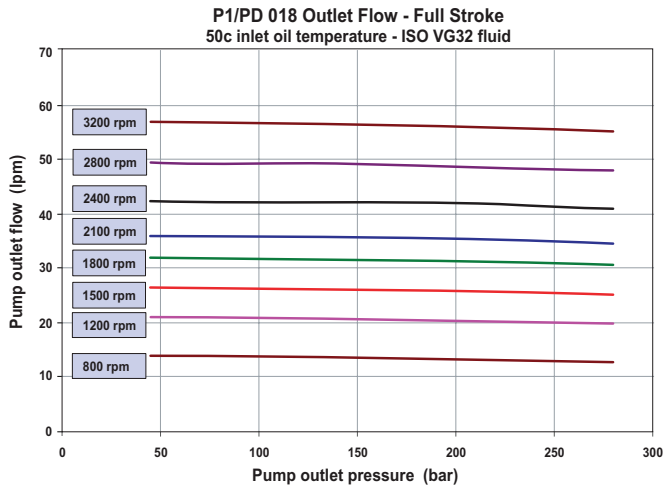

P1/PD Series Typical Pump Outlet Flow

PD Maximum Speed Rating = 1800 rpm

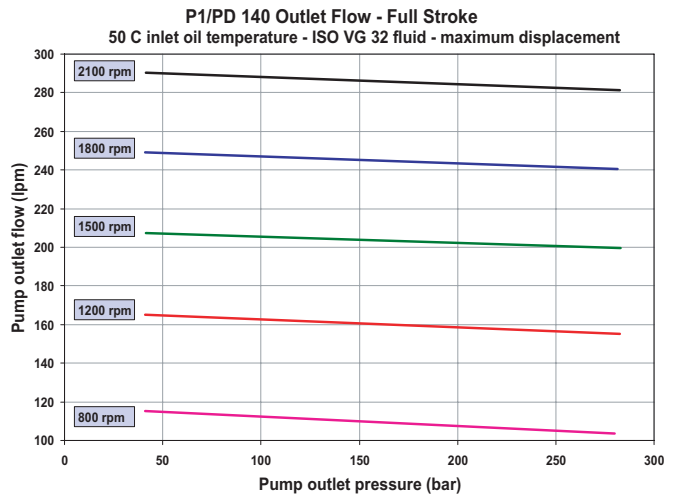
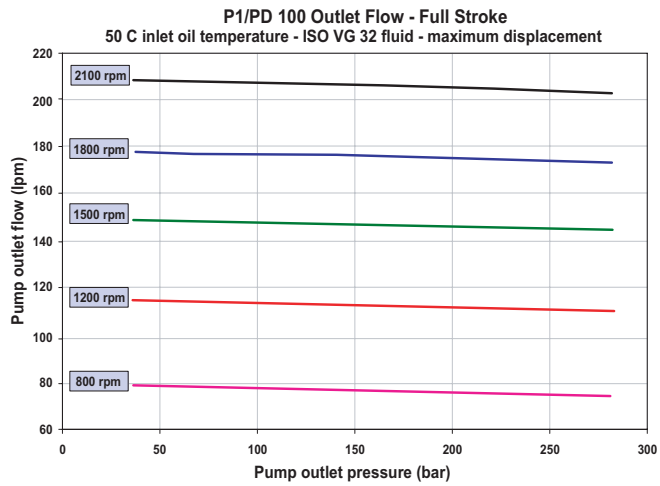
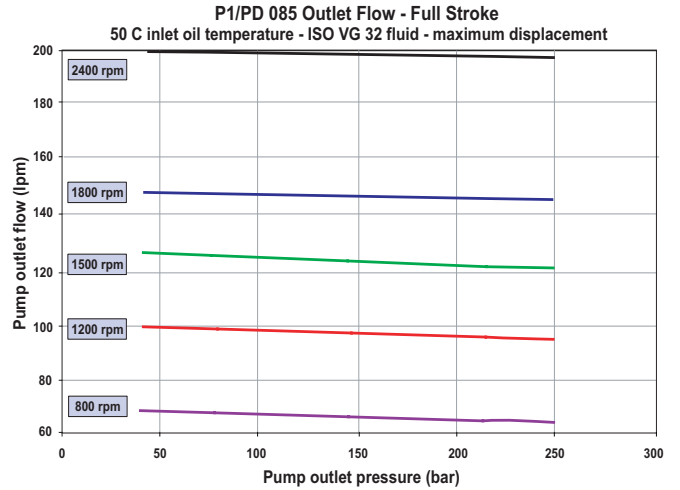
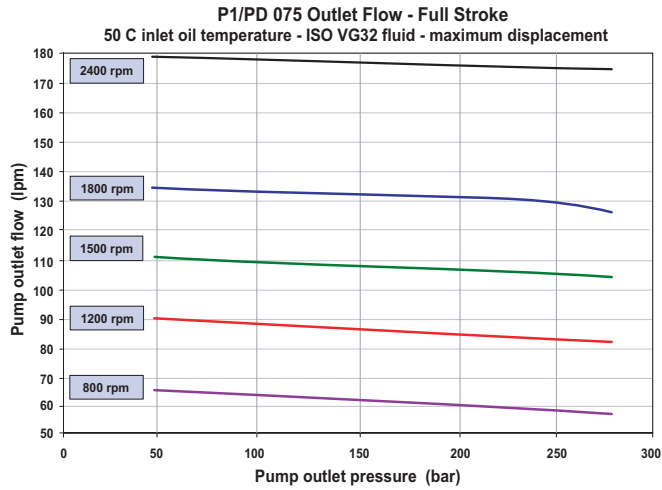

P1/PD Series Typical Shaft Input Power

PD Maximum Speed Rating = 1800 rpm

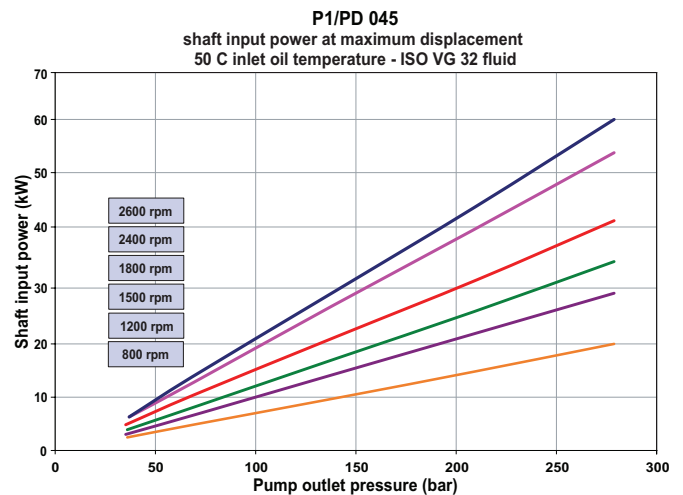
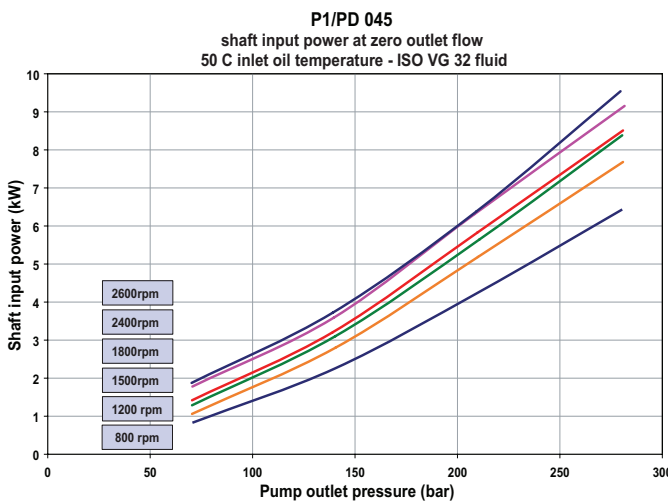
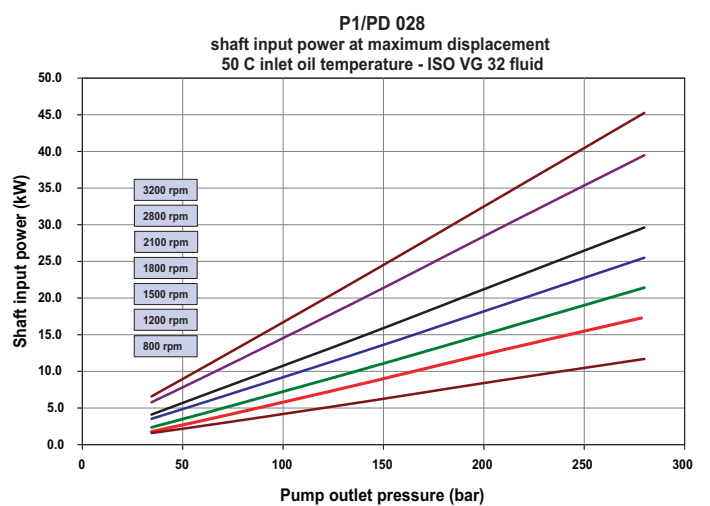
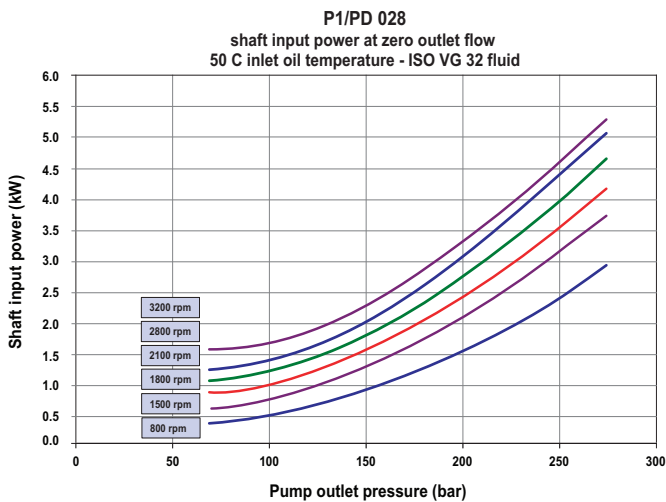
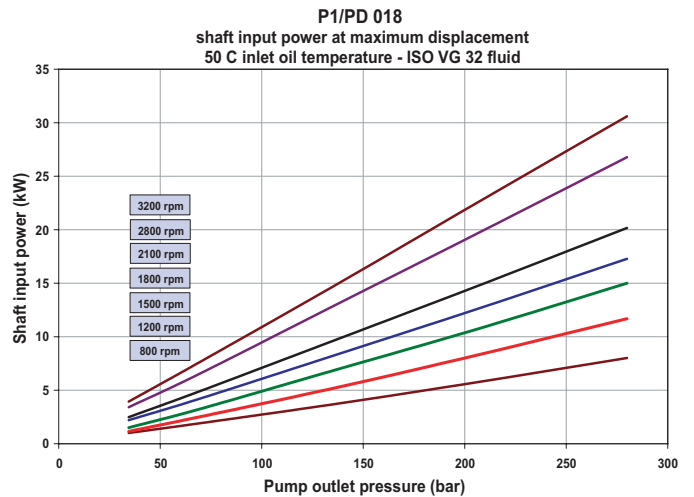
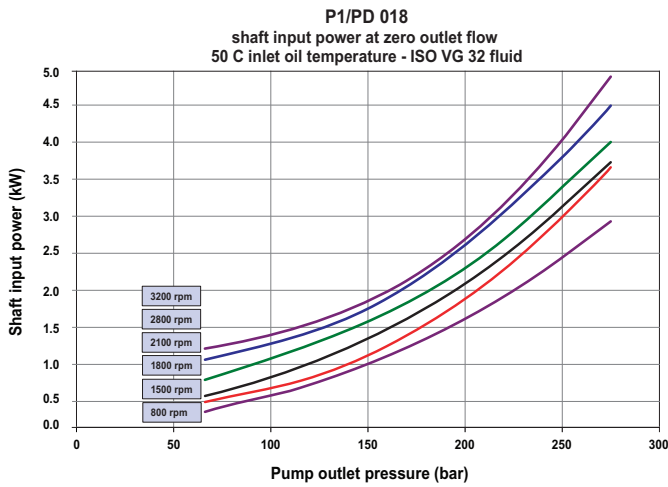

P1/PD Series Typical Shaft Input Power

PD Maximum Speed Rating = 1800 rpm

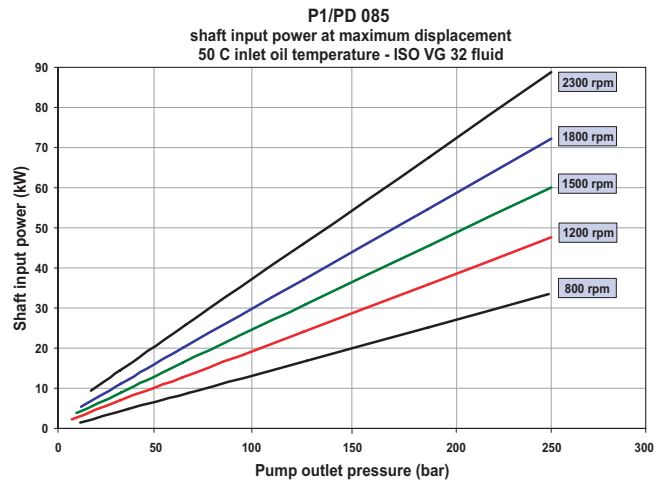
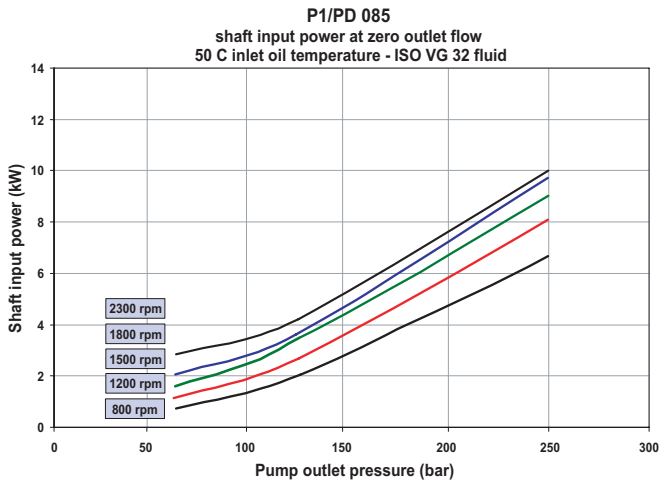
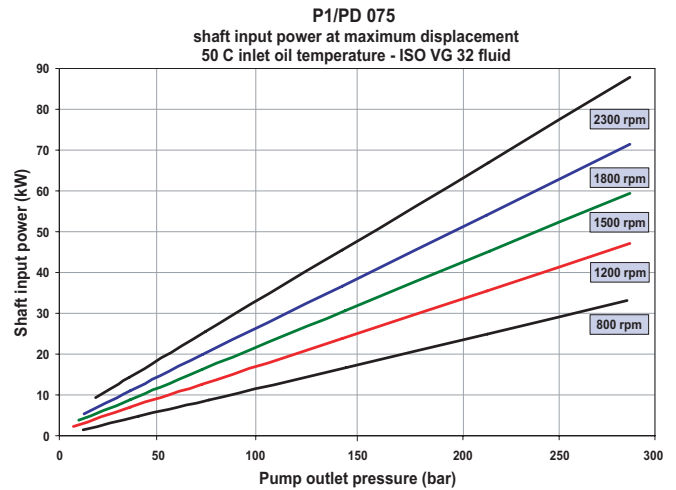
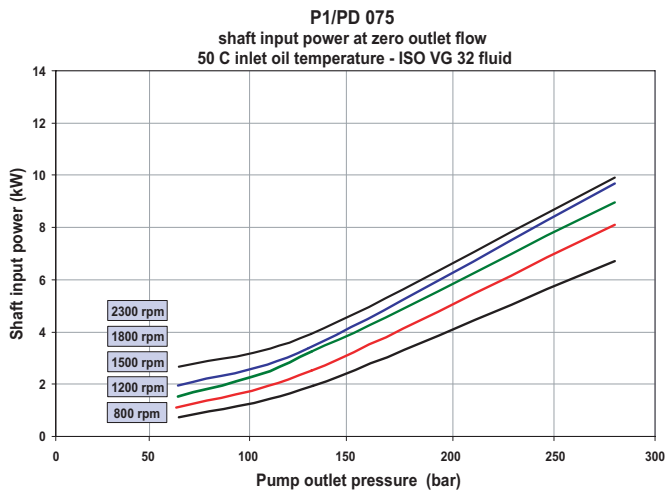
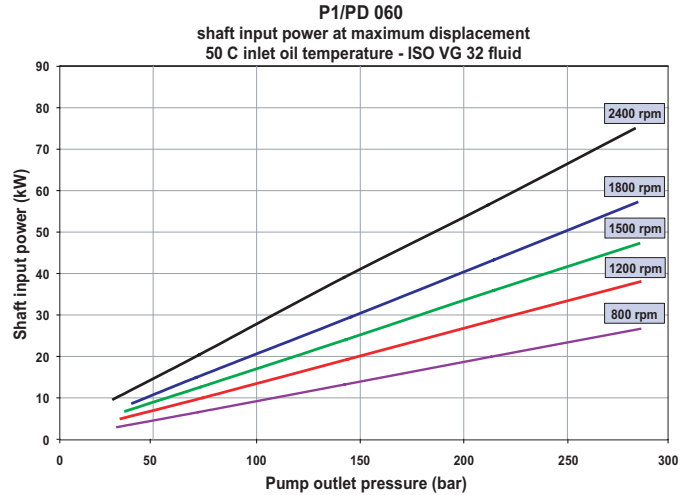
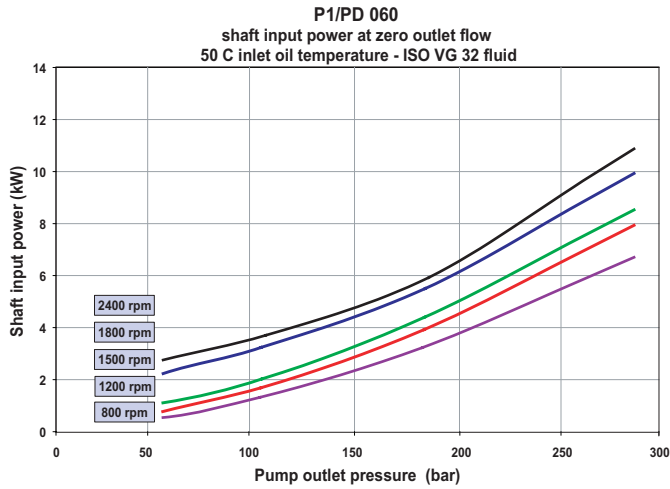

P1/PD Series Typical Shaft Input Power

PD Maximum Speed Rating = 1800 rpm

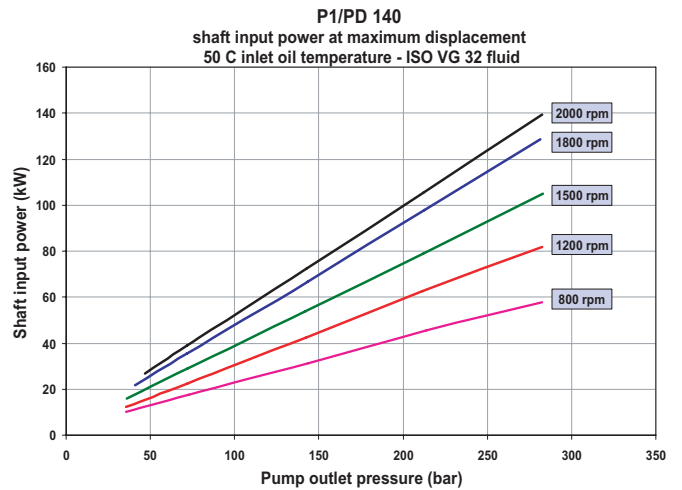
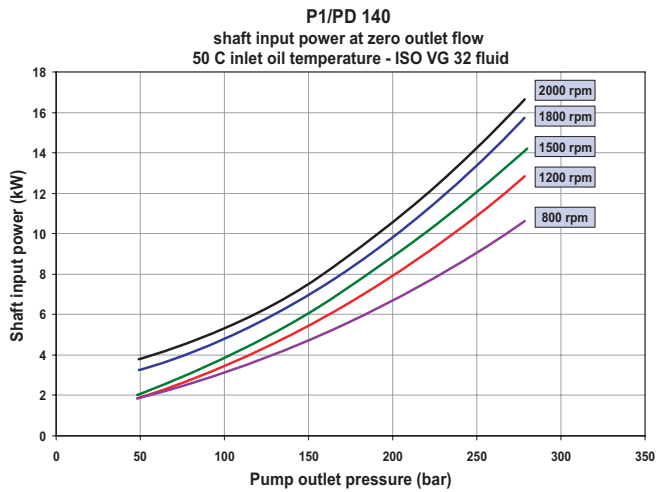
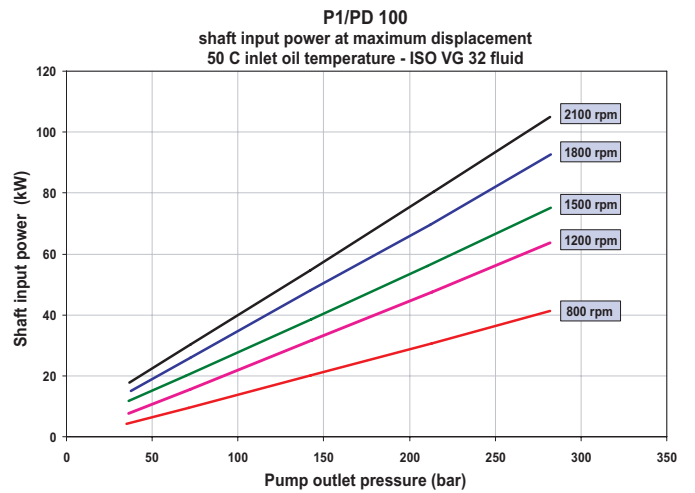
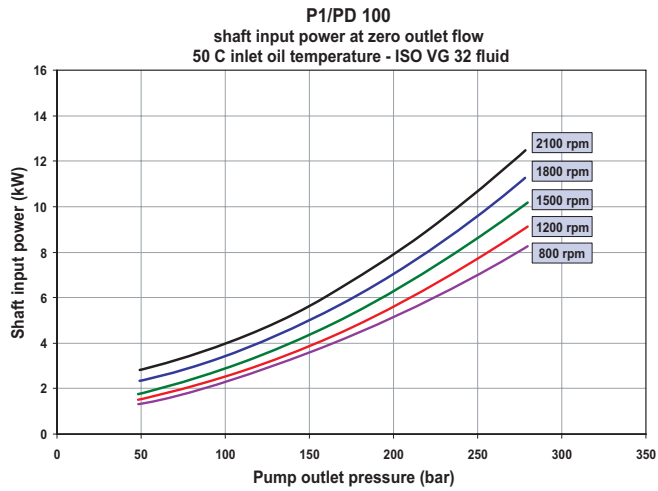

P1/PD Series Typical Shaft Bearing Life

PD Maximum Speed Rating = 1800 rpm

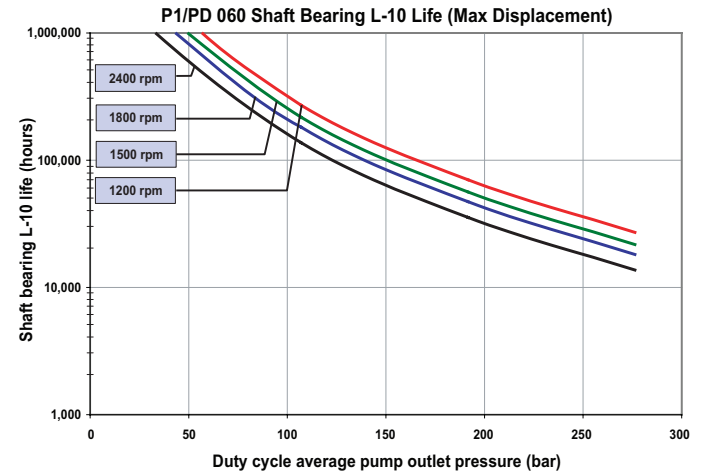
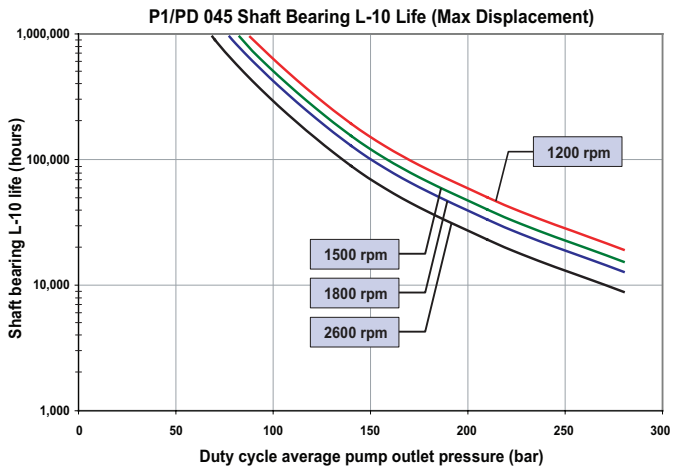
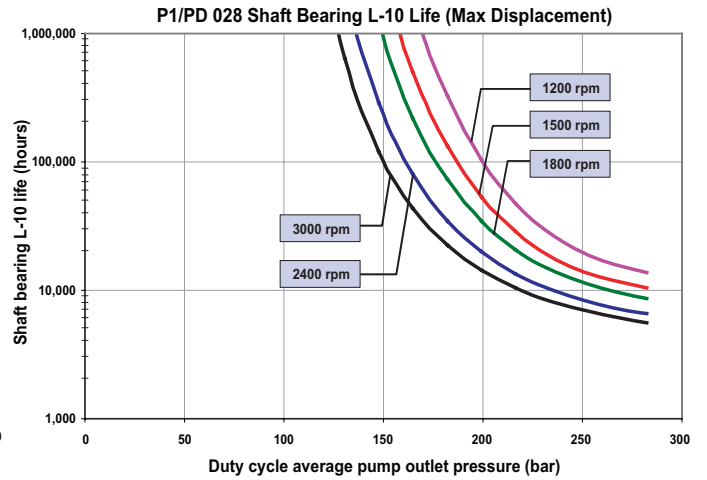
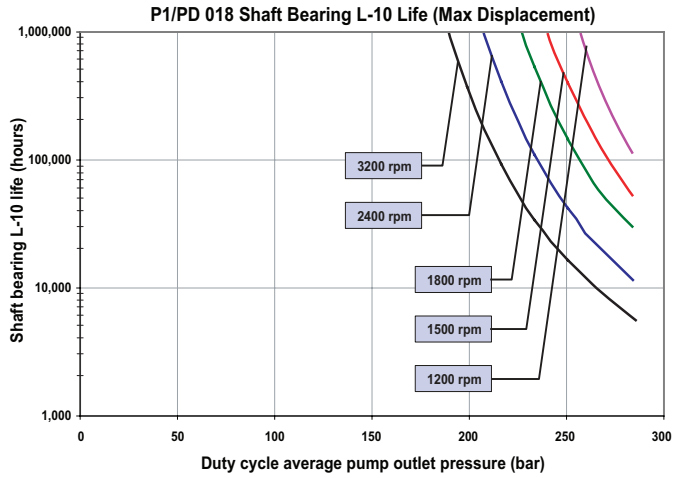

P1/PD Series Typical Shaft Bearing Life

PD Maximum Speed Rating = 1800 rpm

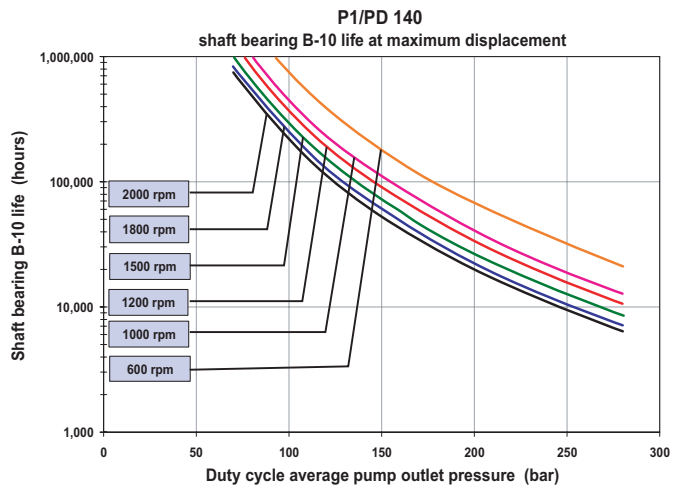
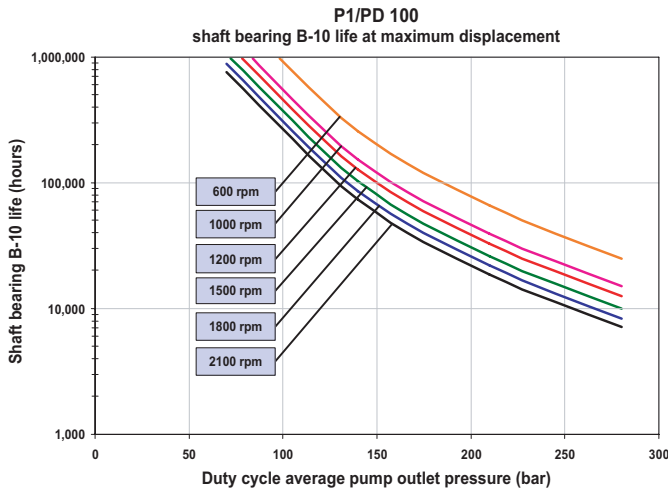
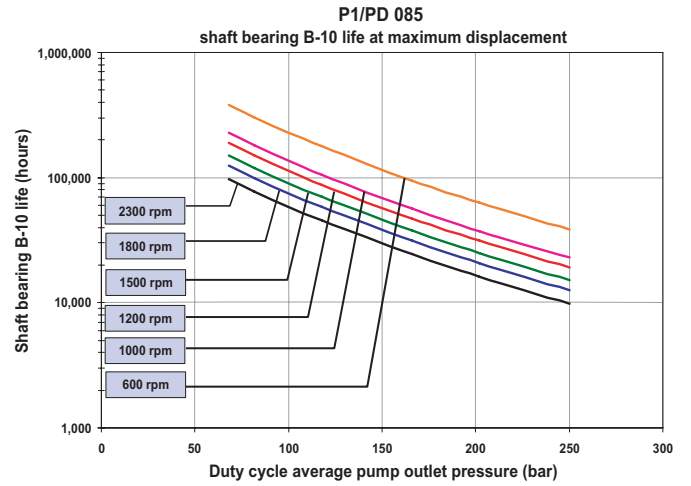
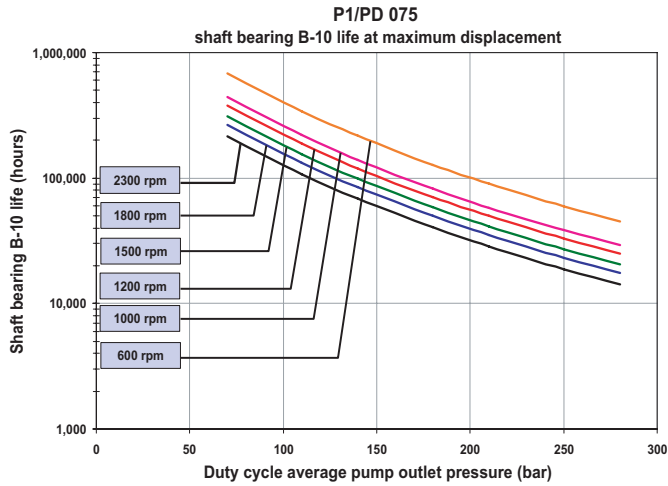

P1 Series Typical Noise Characteristics

(These are anechoic sound pressure readings)

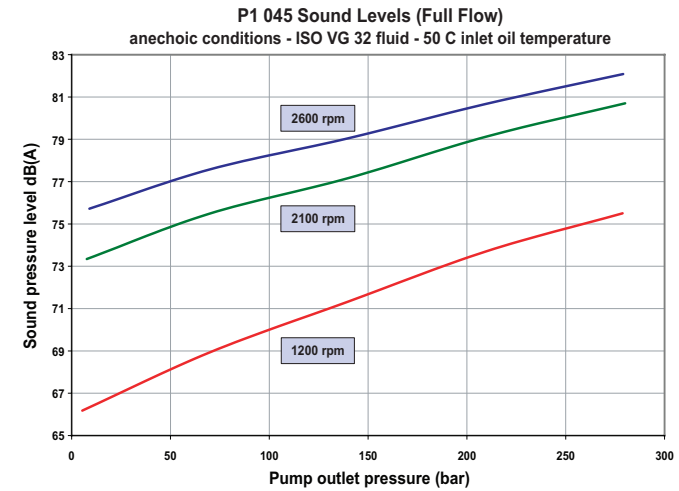
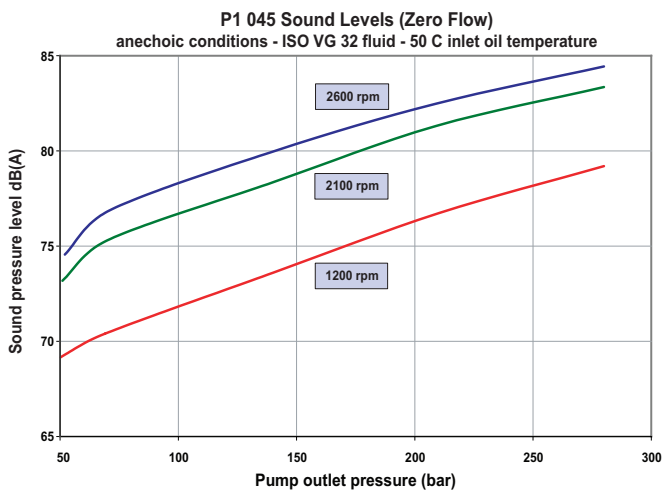
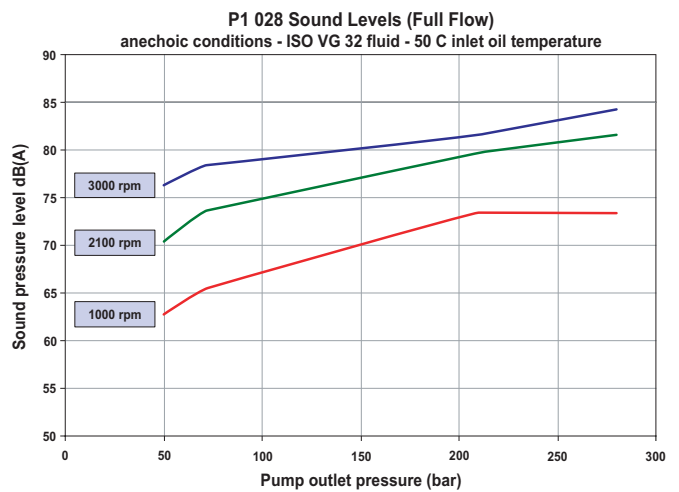
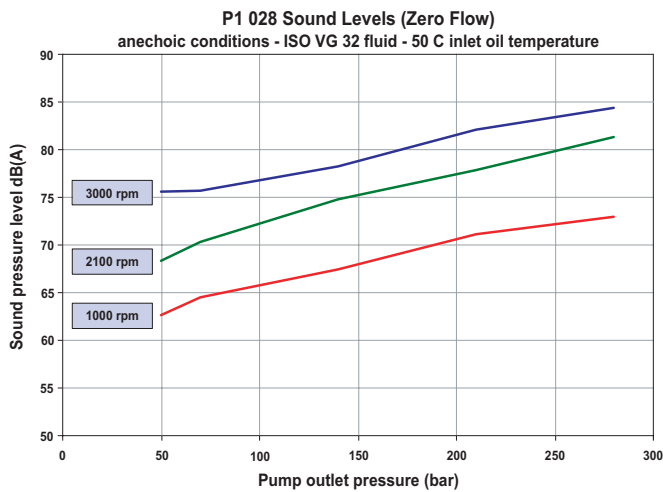
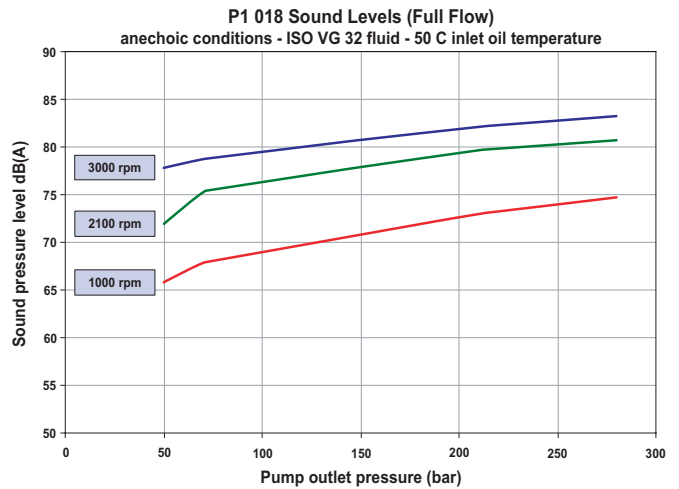
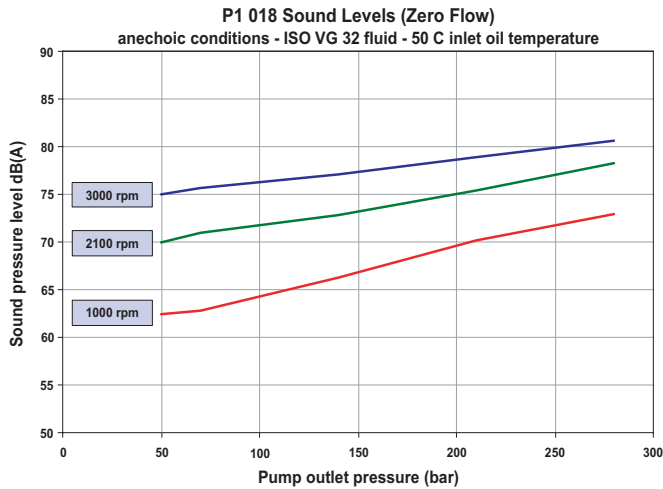

P1 Series Typical Noise Characteristics

(These are anechoic sound pressure readings)

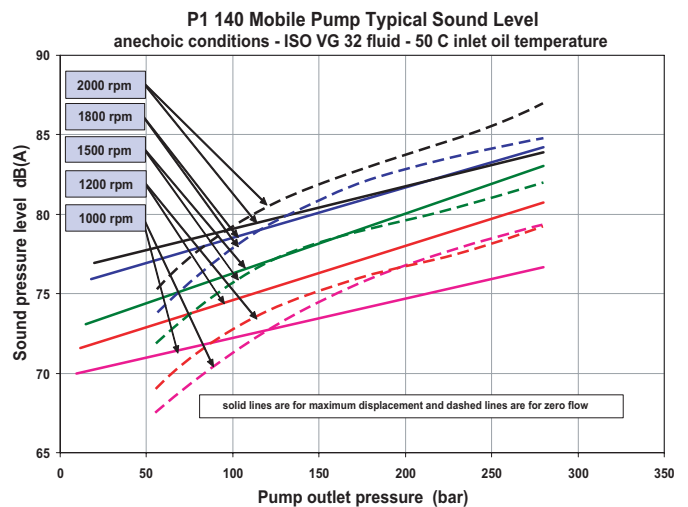
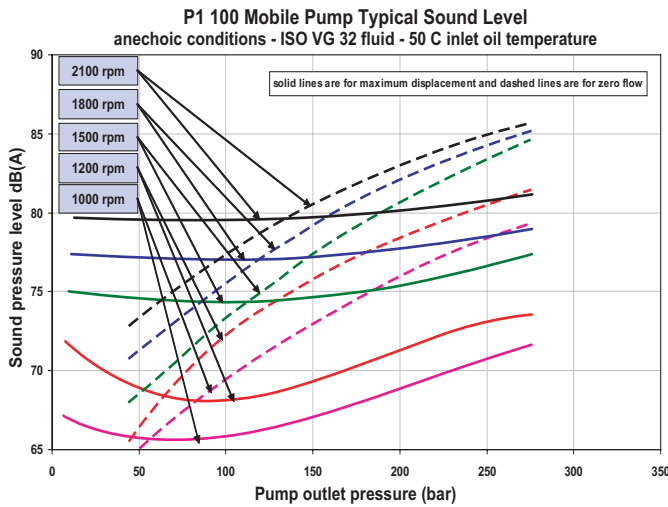
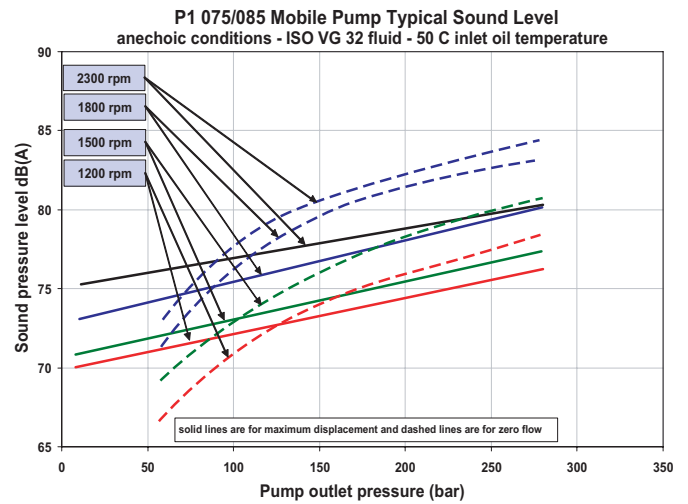
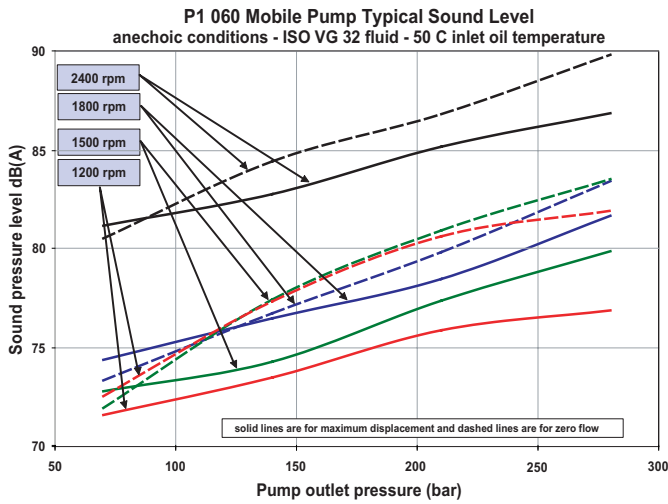

PD Series Typical Noise Characteristics

(These are anechoic sound pressure readings)

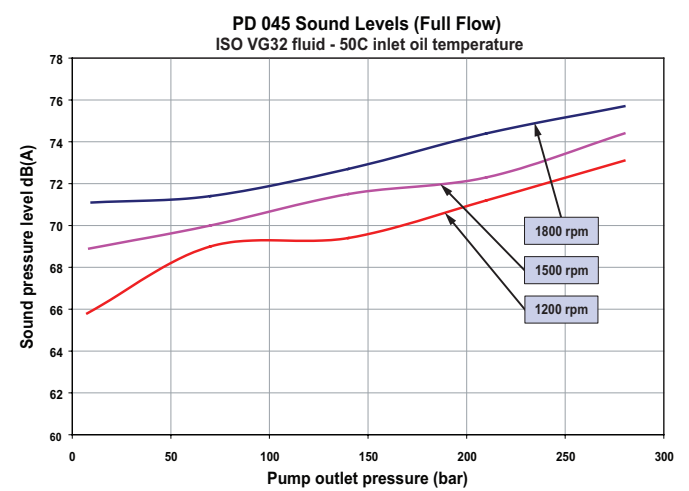
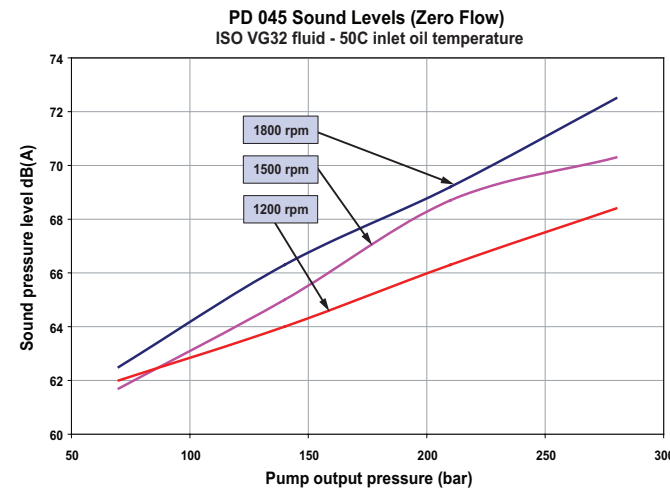
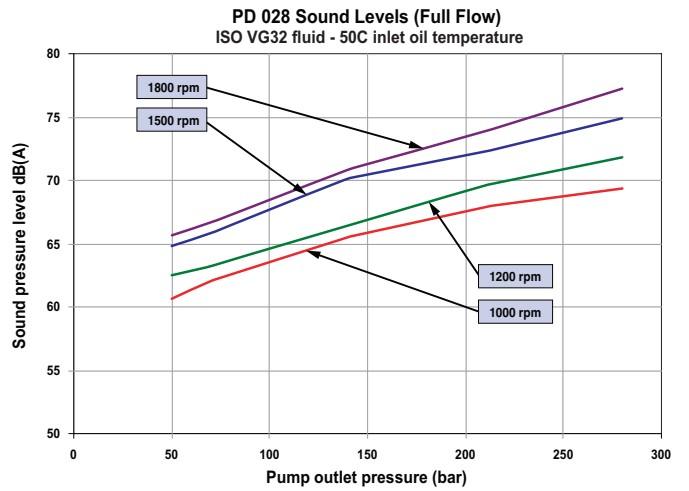
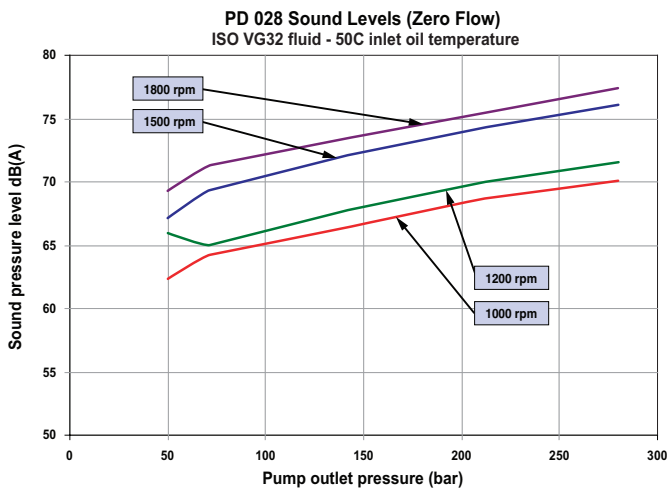
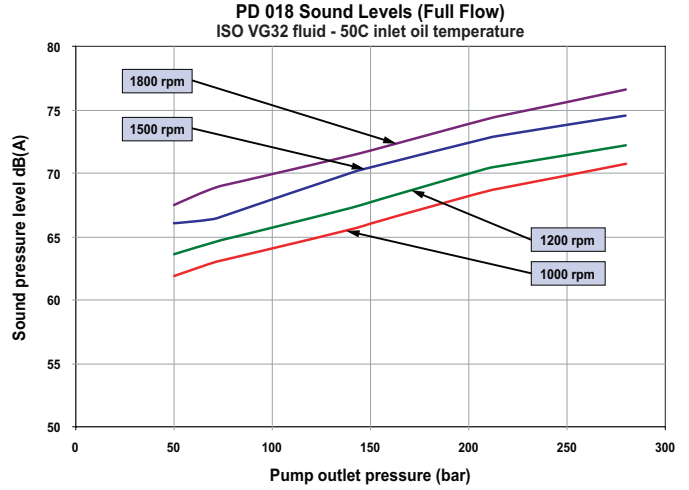
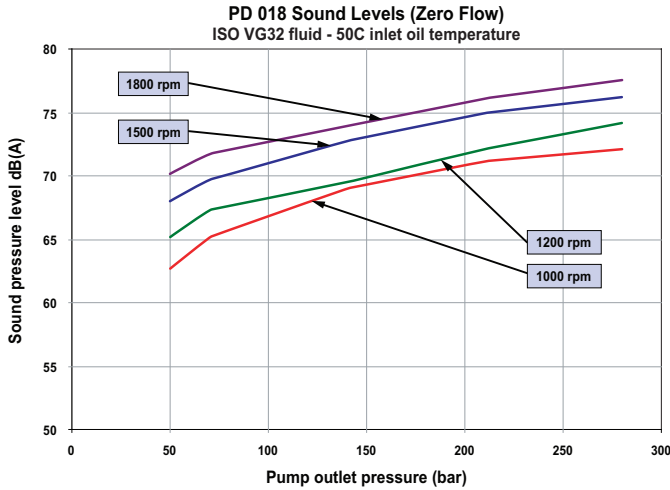

PD Series Typical Noise Characteristics

(These are anechoic sound pressure readings)

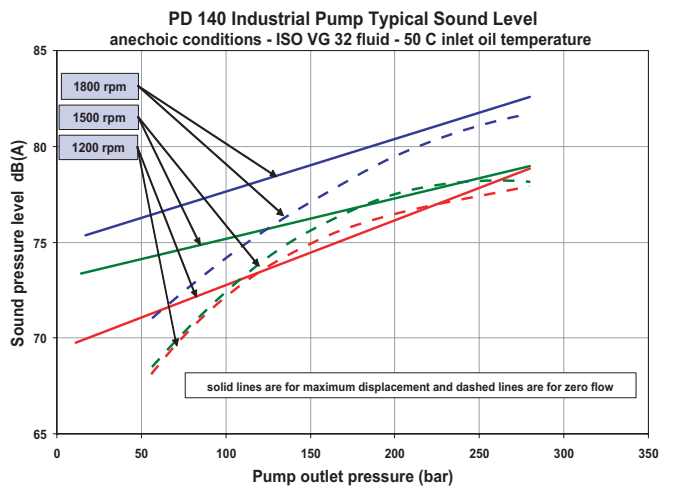
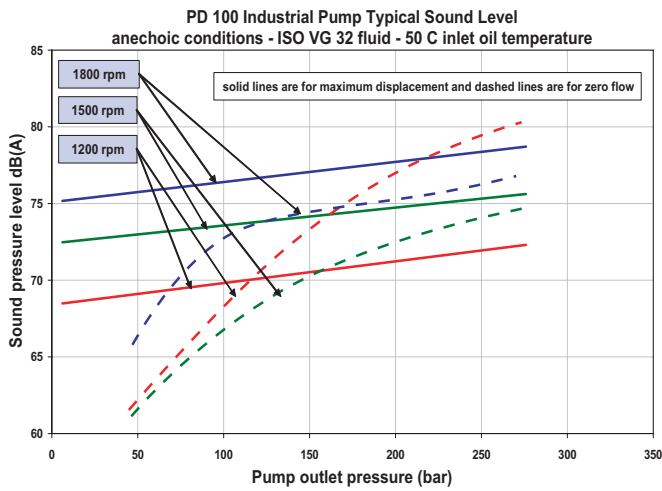
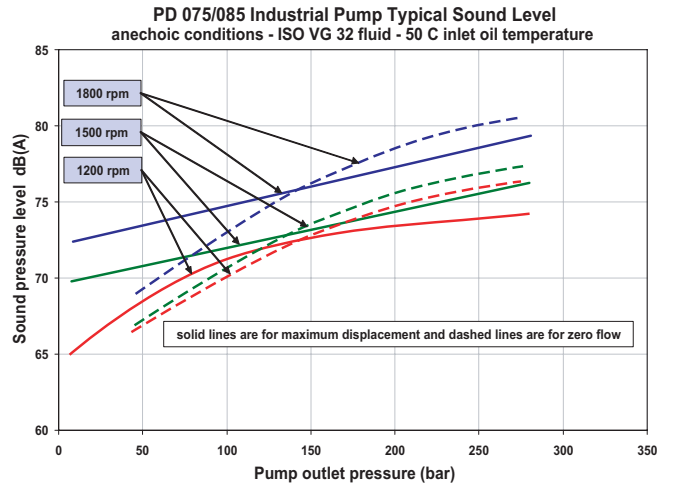
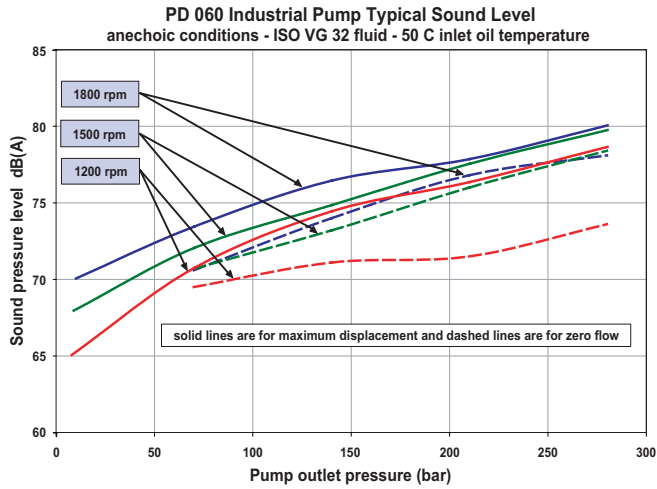

**Pump Installation - P1/PD-018
Input Shaft Dimensions**

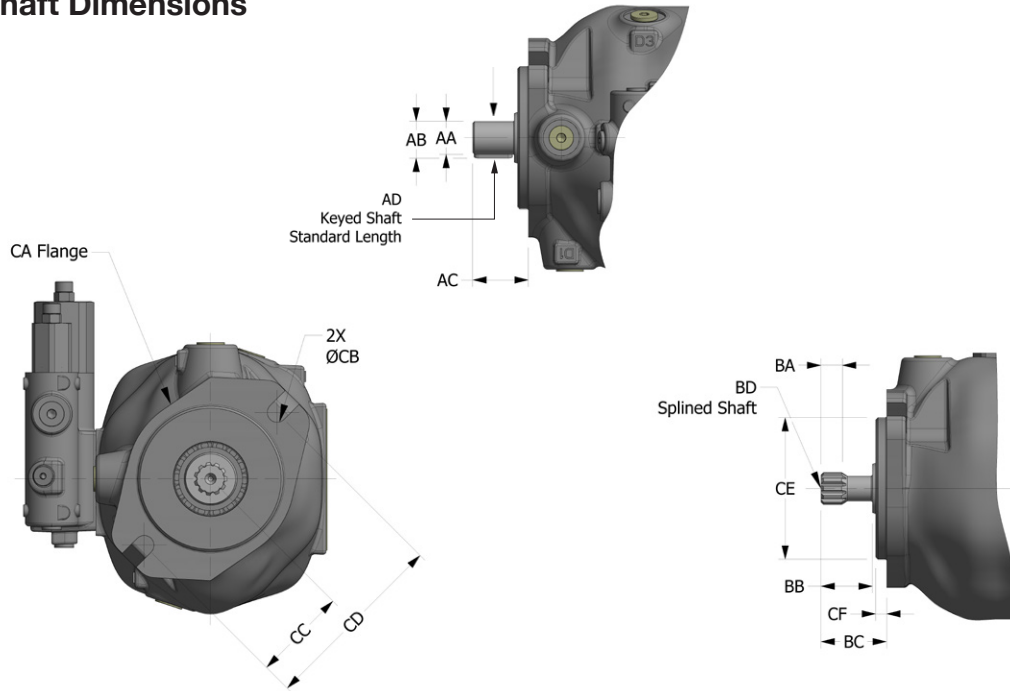

P1/PD-018 Mounting Flange & Shaft Dimensions

Dimension	ISO Key (Code 04)	SAE (Code 01 or 02)	SAE (Code 06)
AA	20.01/19.99	19.05/19.02	N/A
AB	22.61/22.32	21.20/20.89	N/A
AC	44.3	32.3	N/A
AD	ISO 3019-2: E20N	SAE J744 19-1	N/A
BA	N/A	12.0	12.5
BB	N/A	30.0	24.0
BC	N/A	38.3	32.3
BD	N/A	SPLINE: ANSI 92.1-1996 SAE 19-4 INVOLUTE SPLINE CLASS 7 FLAT ROOT SIDE FIT NUMBER OF TEETH - 11 PITCH - 16/32 PRESSURE ANGLE - 30° MAJOR DIAMETER - 19.05/18.49 PITCH DIAMETER - 17.463	SPLINE: ANSI 92.1-1996 SAE 16-4 (A) INVOLUTE SPLINE CLASS 7 FLAT ROOT SIDE FIT NUMBER OF TEETH - 9 PITCH - 16/32 PRESSURE ANGLE - 30° MAJOR DIAMETER - 15.88/15.32 PITCH DIAMETER - 12.288
CA	ISO 3019-2: 80A2SW	SAE J744: JUN 96 82-2 (A)	SAE J744: JUN 96 82-2 (A)
CB	11.1	11.1	11.1
CC	54.5	53.2	53.2
CD	109.0	106.4	106.4
CE	80.00/79.95	82.55/82.50	82.55/82.50
CF	7.0	6.35	6.35
Keyway Width	6.05/6.00	4.81/4.76	N/A

**Pump Installation - P1/PD-018
End Port
“L” or “AM” Control Option**

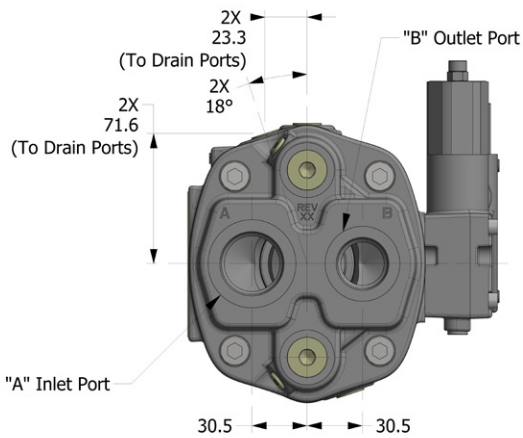
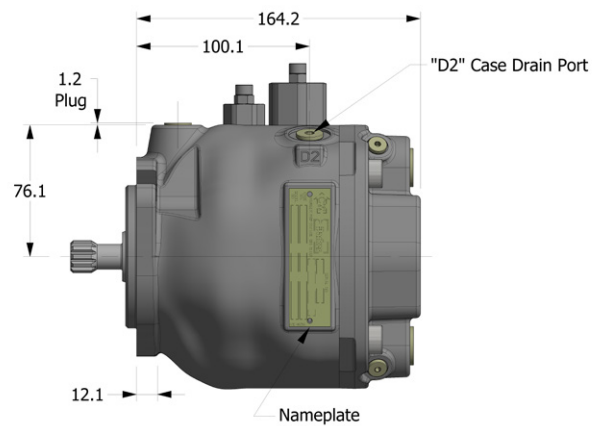
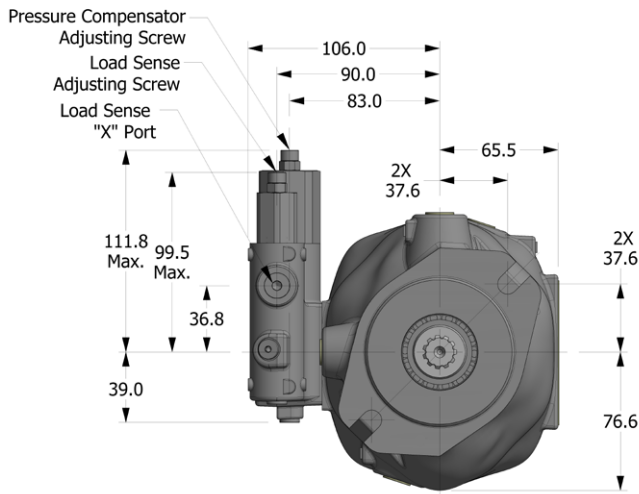
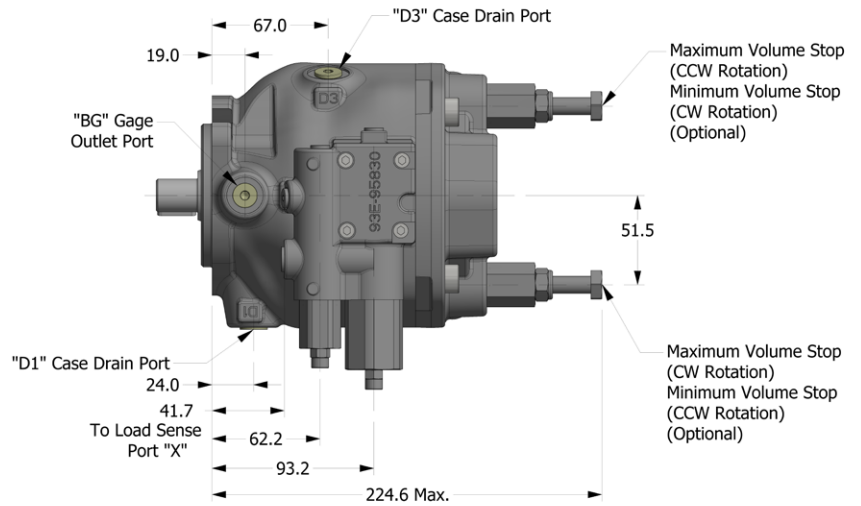

P1/PD-018 Port Sizes			
Ports	SAE Threaded	Metric Threaded	BSP
"A" Inlet	SAE-16	M33x2	-
"B" Outlet	SAE-12	M27x2	-
BG, X	SAE-4	M12x1.5	1/4"
D1, D2, D3	SAE-6	M16x1.5	3/8"

Note A: SAE o-ring port conforms to SAE J514
 Note B: Metric o-ring boss port conforms to ISO 6149-1
 Note C: BSP port conforms to ISO 228-1

**Pump Installation - P1/PD-018
Side Port
“L” or “AM” Control Option**

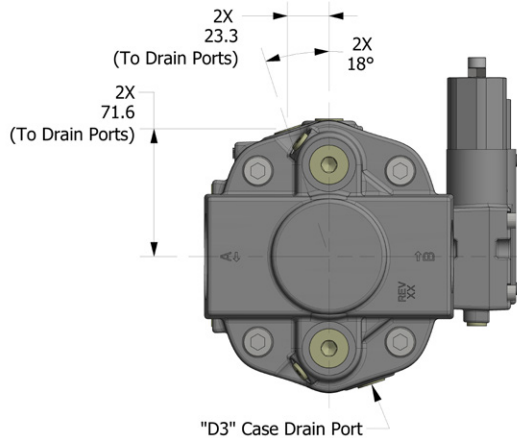
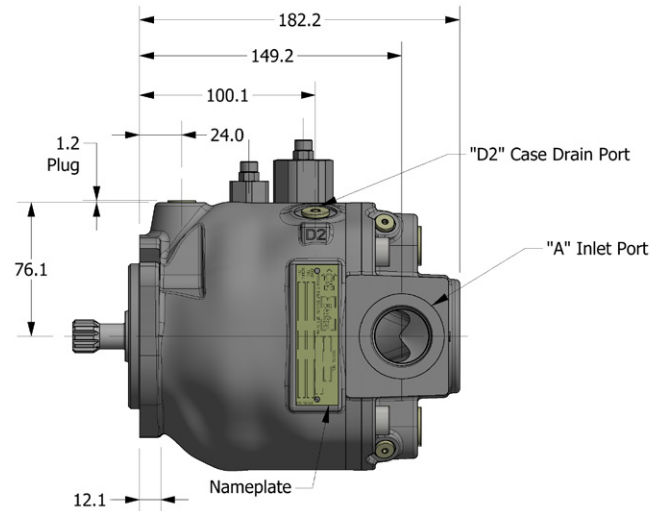
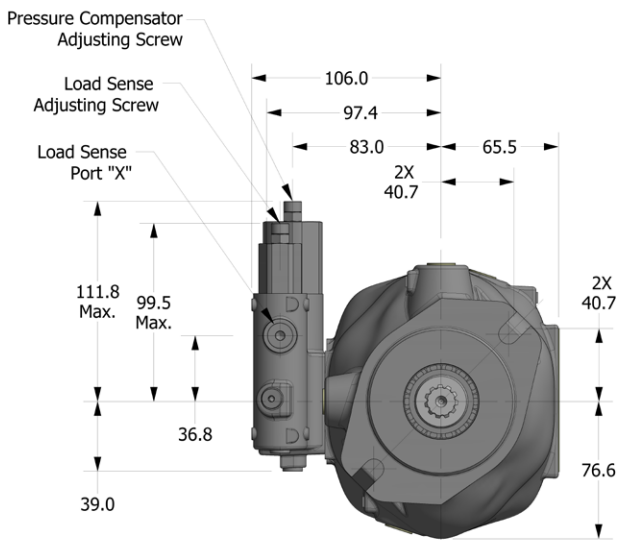
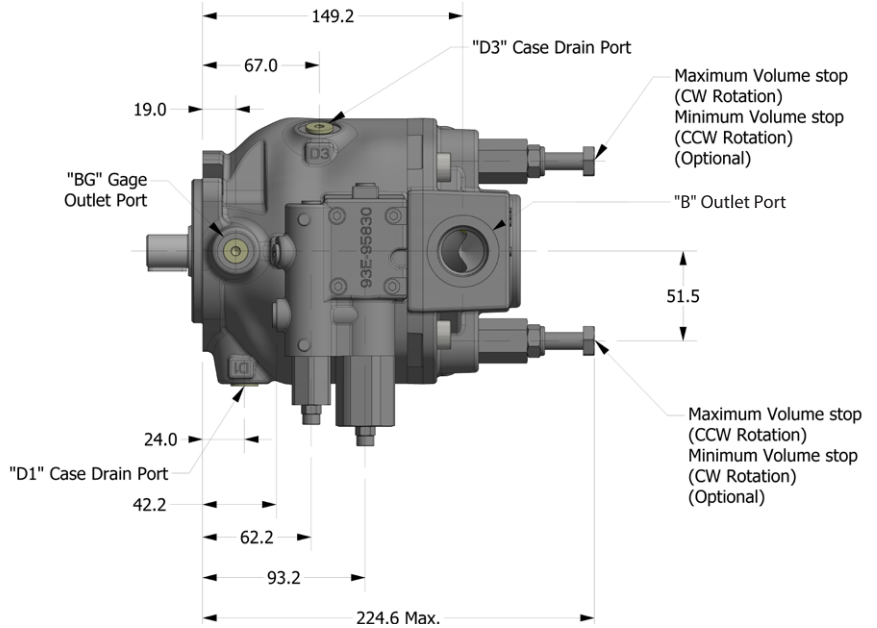

P1/PD-018 Port Sizes			
Ports	SAE Threaded	Metric Threaded	BSPB
"A" Inlet	SAE-16	M33x2	-
"B" Outlet	SAE-12	M27x2	-
BG, X	SAE-4	M12x1.5	1/4"
D1, D2, D3	SAE-6	M16x1.5	3/8"

Note A: SAE o-ring port conforms to SAE J514
 Note B: Metric o-ring boss port conforms to ISO 6149-1
 Note C: BSPB port conforms to ISO 228-1

**Pump Installation - P1/PD-018
Side Ports with Thru-Drive
"L" or "AM" Control Option**

P1/PD-018 Port Sizes					
Ports	SAE Flanged	SAE Threaded	Metric Flanged	Metric Threaded	BSPP
"A" Inlet	1" Code 61	SAE-16	DN25	M33x2	-
W Threads	3/8-16 UNC-2B	-	M10x1.5-6H	-	-
"B" Outlet	3/4" Code 61	SAE-12	DN20	M27x2	-
Y Threads	3/8-16 UNC-2B	-	M10x1.5-6H	-	-
BG, X	SAE-4		M12x1.5		1/4"
D1, D2, D3	SAE-6		M16x1.5		3/8"

Note A: SAE flanged ports conform to SAE J518
 Note B: SAE o-ring port conforms to SAE J514
 Note C: Metric flanged ports conform to ISO 6162
 Note D: Metric o-ring boss port conforms to ISO 6149-1
 Note E: BSPP port conforms to ISO 228-1

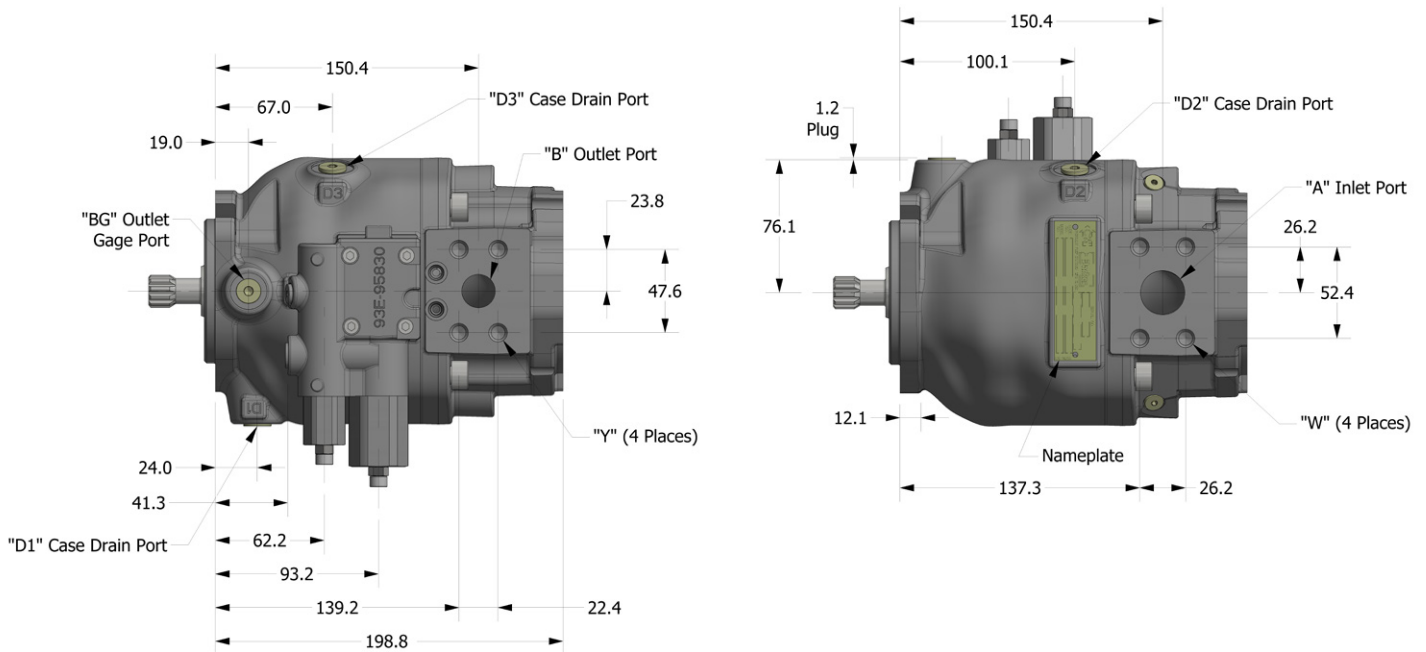

Thru-Drive Mounting Options

SAE-A Mounting Options Information
Model Number T0*A Spline: ANSI B92.1 1996 SAE 16-4 (A) Involute Spline Class 7 Flat Root Side Fit Number of Teeth - 9 Pitch - 16/32 Pressure Angle - 30° Major Diameter - 13.06/12.93 mm Pitch Diameter - 14.29 mm
Model Number T0*H Spline: ANSI B92.1 1996 SAE 19-4 Involute Spline Class 7 Flat Root Side Fit Number of Teeth - 11 Pitch - 16/32 Pressure Angle - 30° Minor Diameter - 16.14/16.02 mm Pitch Diameter - 17.46 mm

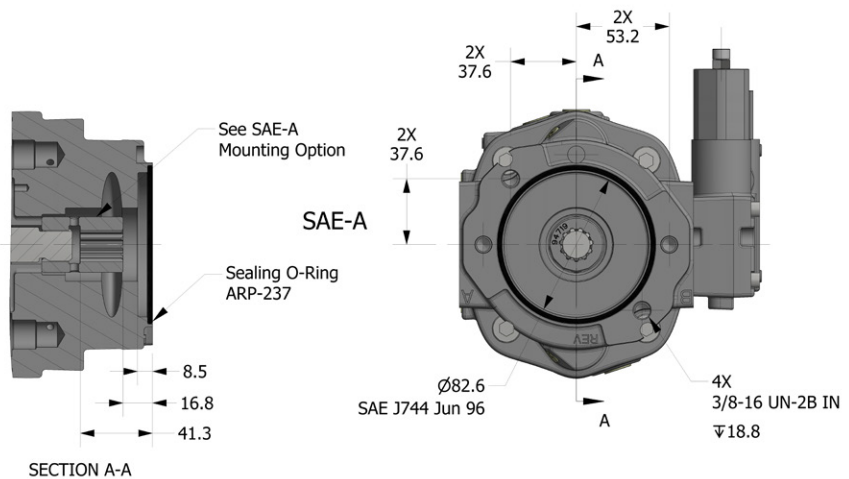

**Pump Installation - P1/PD-028
Input Shaft Dimensions**

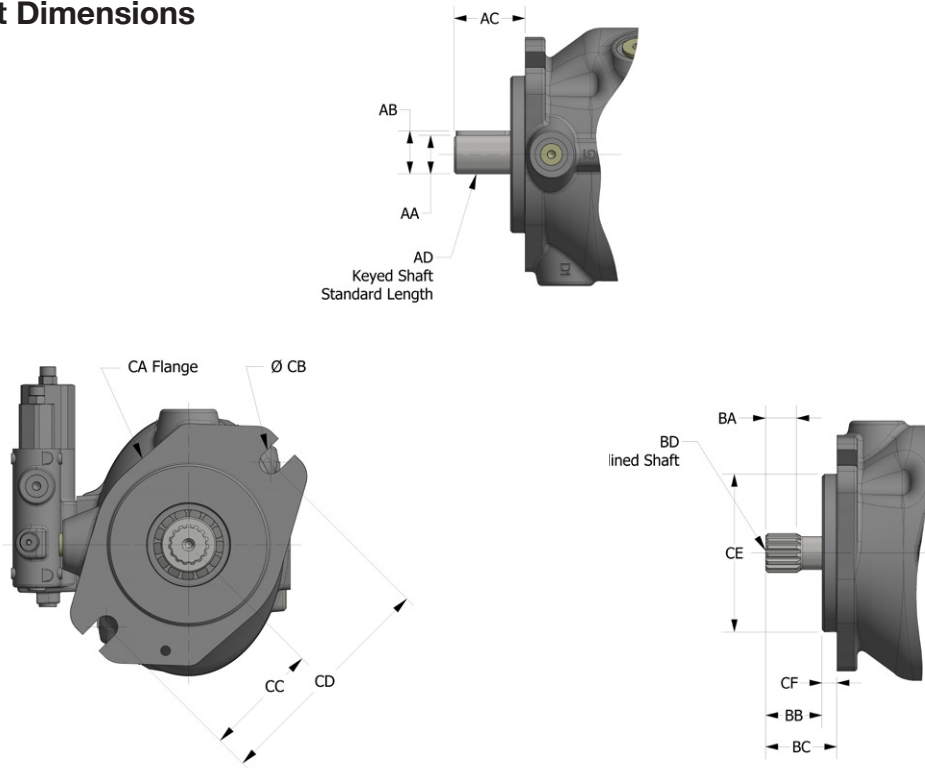

P1/PD-028 Mounting Flange & Shaft Dimensions			
Dimension	ISO (Code 04)	SAE (Code 01 or 02)	SAE (Code 08)
AA	25.01/24.99	25.40/25.35	N/A
AB	27.20/26.71	28.16/27.80	N/A
AC	50.0	46.0	N/A
AD	ISO 3019-2: E25N	SAE J744 25-1 (B-B)	N/A
BA	N/A	20.0	15.0
BB	N/A	38.0	33.0
BC	N/A	46.0	41.0
BD	N/A	SPLINE: ANSI B92.1-1996 SAE 25-4 (B-B) INVOLUTE SPLINE CLASS 7 FLAT ROOT SIDE FIT NUMBER OF TEETH - 15 PITCH - 16/32 PRESSURE ANGLE - 30° MAJOR DIAMETER - 25.40/24.84 PITCH DIAMETER - 23.813	SPLINE: ANSI B92.1-1996 SAE 22-4 (B) INVOLUTE SPLINE CLASS 7 FLAT ROOT SIDE FIT NUMBER OF TEETH - 13 PITCH - 16/32 PRESSURE ANGLE - 30° MAJOR DIAMETER - 22.23/21.67 PITCH DIAMETER - 20.638
CA	ISO 3019-2: 100B2SW	SAE J744: JUN96 101-2 (B)	SAE J744: JUN96 101-2 (B)
CB	13.7/13.3	14.6/14.2	14.6/14.2
CC	70.0	73.0	73.0
CD	140.0	146.0	146.0
CE	100.00/99.95	101.60/101.55	101.60/101.55
CF	9.5/9.0	9.7/9.5	9.7/9.5
Keyway Width	8.03/7.98	6.40/6.35	N/A

**Pump Installation - P1/PD-028
End Port
“L” or “AM” Control Option**

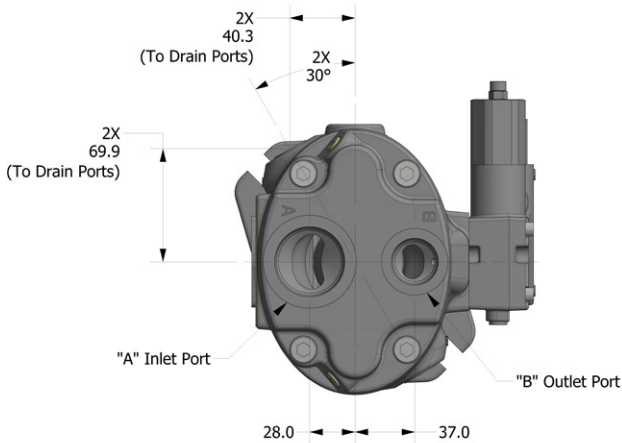
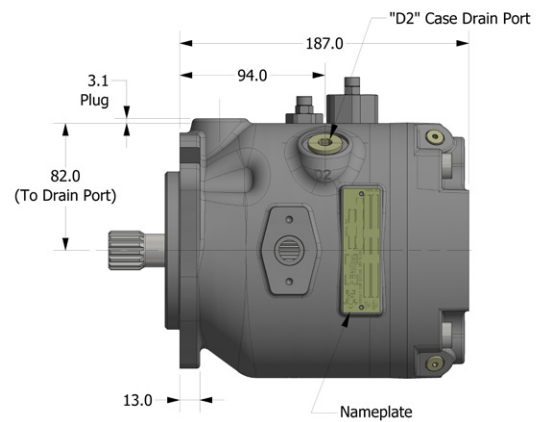
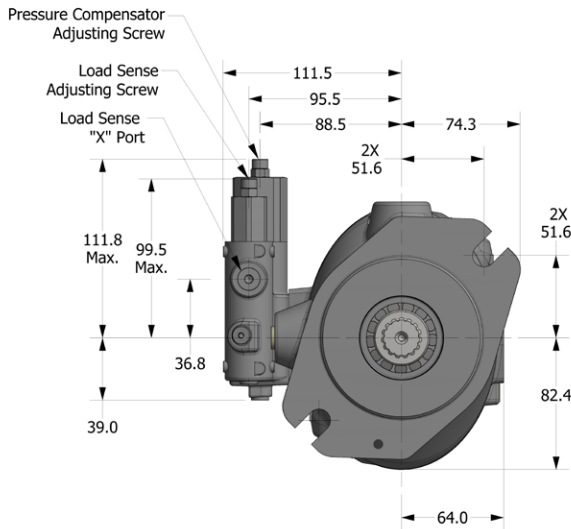
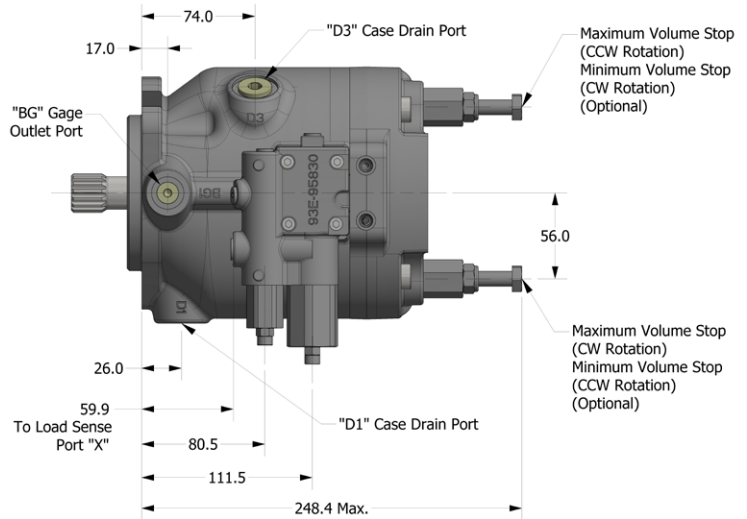

P1/PD-028 Port Sizes					
Ports	SAE Flanged	SAE Threaded	Metric Flanged	Metric Threaded	BSPP
"A" Inlet	1-1/4" Code 61	SAE-20	DN32	M42x2	-
W Threads	7/16-14 UNC-2B	-	M10x1.5-6H	-	-
"B" Outlet	3/4" Code 61	SAE-12	DN19	M27x2	-
Y Threads	3/8-16 UNC-2B	-	M10x1.5-6H	-	-
BG, X	SAE-4		M12x1.5		1/4"
D1, D2, D3	SAE-8		M22x1.5		1/2"

Note A: SAE flanged ports conform to SAE J518
 Note B: SAE o-ring port conforms to SAE J514
 Note C: Metric flanged ports conform to ISO 6162
 Note D: Metric o-ring boss port conforms to ISO 6149-1
 Note E: BSPP port conforms to ISO 228-1

**Pump Installation - P1/PD-028
Side Port
"L" or "AM" Control Option**

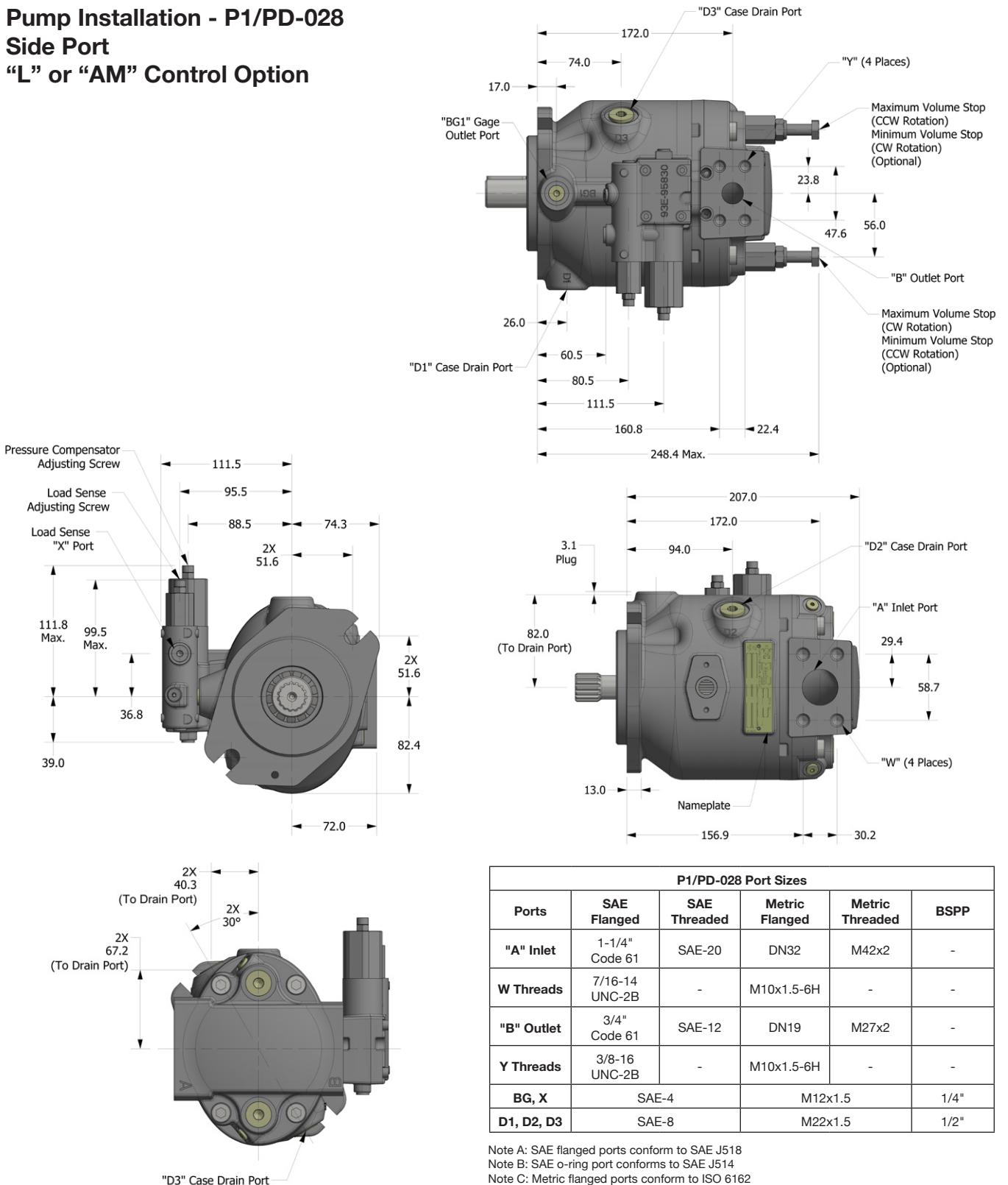

P1/PD-028 Port Sizes					
Ports	SAE Flanged	SAE Threaded	Metric Flanged	Metric Threaded	BSPP
"A" Inlet	1-1/4" Code 61	SAE-20	DN32	M42x2	-
W Threads	7/16-14 UNC-2B	-	M10x1.5-6H	-	-
"B" Outlet	3/4" Code 61	SAE-12	DN19	M27x2	-
Y Threads	3/8-16 UNC-2B	-	M10x1.5-6H	-	-
BG, X	SAE-4		M12x1.5		1/4"
D1, D2, D3	SAE-8		M22x1.5		1/2"

Note A: SAE flanged ports conform to SAE J518
 Note B: SAE o-ring port conforms to SAE J514
 Note C: Metric flanged ports conform to ISO 6162
 Note D: Metric o-ring boss port conforms to ISO 6149-1
 Note E: BSPP port conforms to ISO 228-1

**Pump Installation - P1/PD-028
Side Ports with Thru-Drive
“L” or “AM” Control Option**

P1/PD-028 Port Sizes					
Ports	SAE Flanged	SAE Threaded	Metric Flanged	Metric Threaded	BSPP
"A" Inlet	1-1/4" Code 61	SAE-20	DN32	M42x2	-
W Threads	7/16-14 UNC-2B	-	M10x1.5-6H	-	-
"B" Outlet	3/4" Code 61	SAE-12	DN19	M27x2	-
Y Threads	3/8-16 UNC-2B	-	M10x1.5-6H	-	-
BG, X	SAE-4		M12x1.5		1/4"
D1, D2, D3	SAE-8		M22x1.5		1/2"

Note A: SAE flanged ports conform to SAE J518
 Note B: SAE o-ring port conforms to SAE J514
 Note C: Metric flanged ports conform to ISO 6162
 Note D: Metric o-ring boss port conforms to ISO 6149-1
 Note E: BSPP port conforms to ISO 228-1

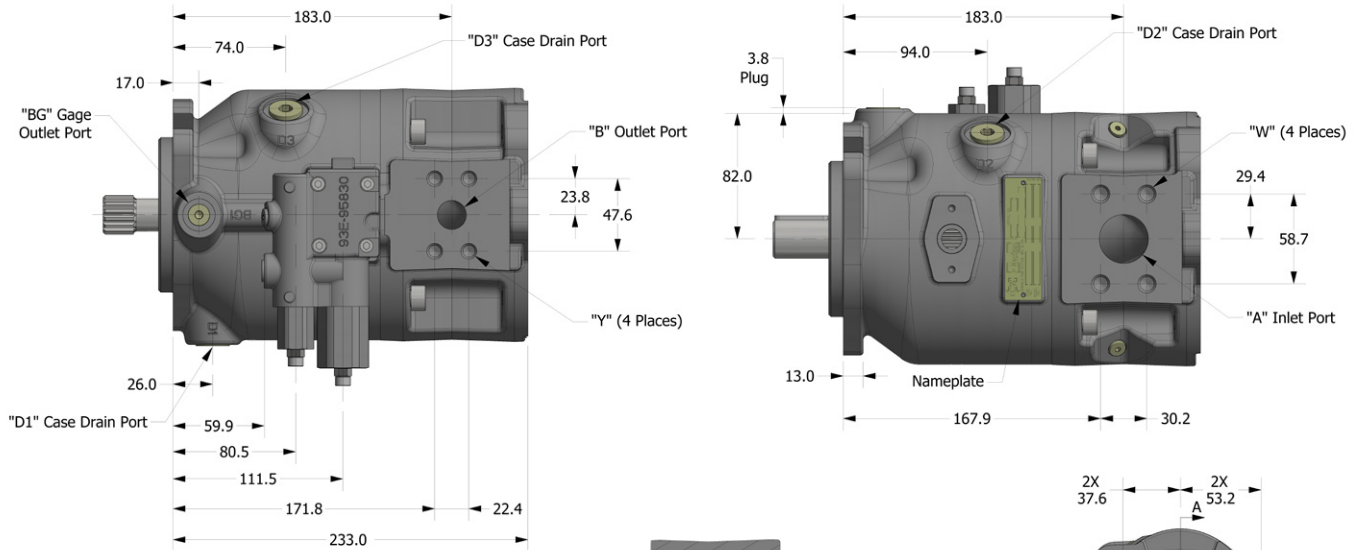

Thru-Drive Mounting Options

SAE-A Mounting Options Information	
Model Number T0*A Spline: ANSI B92.1 1996 SAE 16-4 (A) Involute Spline Class 7 Flat Root Side Fit Number of Teeth - 9 Pitch - 16/32 Pressure Angle - 30° Major Diameter - 13.06/12.93 mm Pitch Diameter - 14.29 mm	Model Number T0*H Spline: ANSI B92.1 1996 SAE 19-4 Involute Spline Class 7 Flat Root Side Fit Number of Teeth - 11 Pitch - 16/32 Pressure Angle - 30° Minor Diameter - 16.14/16.02 mm Pitch Diameter - 17.46 mm

SAE-B Mounting Options Information	
Model Number T0*B Spline: ANSI B92.1 1996 SAE 22-4 (B) Involute Spline Class 7 Flat Root Side Fit Number of Teeth - 13 Pitch - 16/32 Pressure Angle - 30° Minor Diameter - 19.28/19.15 mm Pitch Diameter - 20.64 mm	Model Number T0*Q Spline: ANSI B92.1 1996 SAE 25-4 (B-B) Involute Spline Class 7 Flat Root Side Fit Number of Teeth - 15 Pitch - 16/32 Pressure Angle - 30° Minor Diameter - 22.40/22.28 mm Pitch Diameter - 23.81 mm

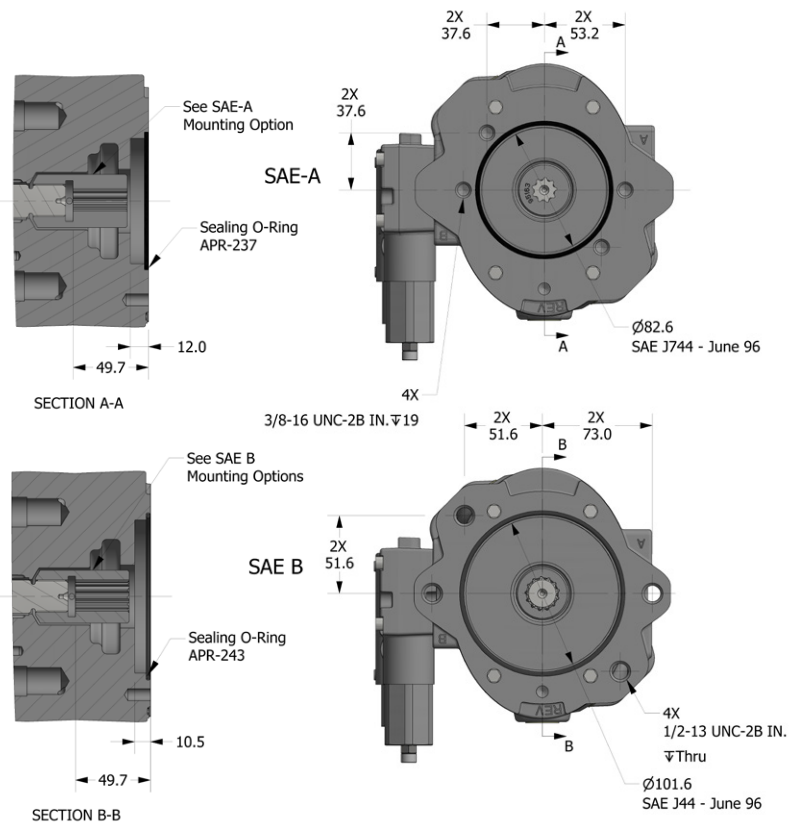

**Pump Installation - P1/PD-045
Input Shaft Dimensions**

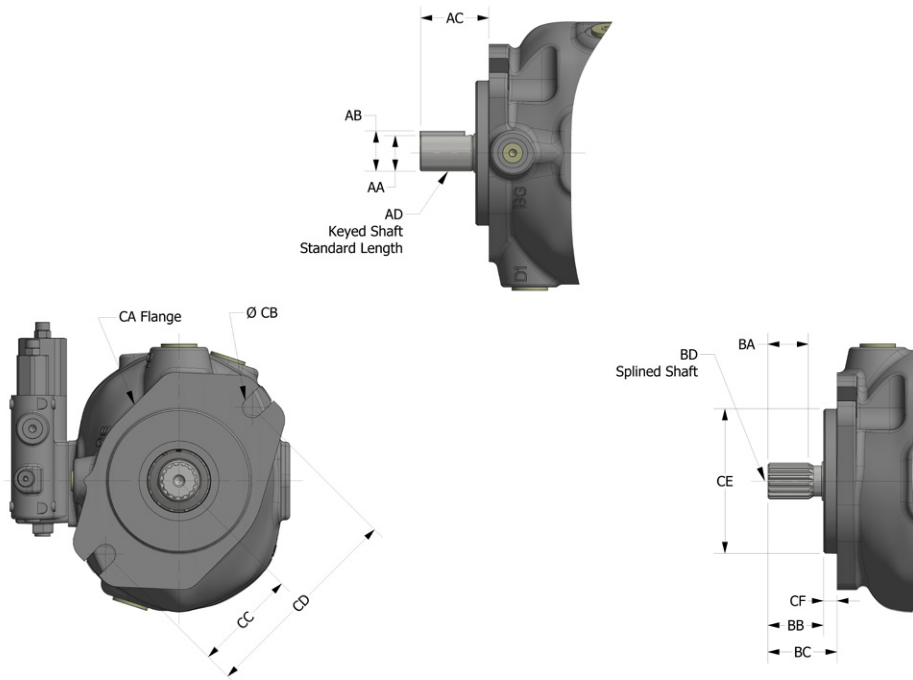

P1/PD-045 Mounting Flange & Shaft Dimensions			
Dimension	ISO (Code 04)	SAE (Code 01 or 02)	SAE (Code 08)
AA	25.01/24.99	25.40/25.35	N/A
AB	28.01/27.77	28.26/27.97	N/A
AC	52.0	46.0	N/A
AD	ISO 3019-2: E25N	SAE J744 25-1 (B-B)	N/A
BA	N/A	28.5	23.0
BB	N/A	38.0	33.0
BC	N/A	46.0	41.0
BD	N/A	SPLINE: ASA B5.15-1960 SAE 25-4 (B-B) INVOLUTE SPLINE CLASS 2 FLAT ROOT SIDE FIT NUMBER OF TEETH - 15 PITCH - 16/32 PRESSURE ANGLE - 30° MAJOR DIAMETER - 24.98/24.85 PITCH DIAMETER - 23.813	SPLINE: ASA B5.15-1960 SAE 22-4 (B) INVOLUTE SPLINE CLASS 2 FLAT ROOT SIDE FIT NUMBER OF TEETH - 13 PITCH - 16/32 PRESSURE ANGLE - 30° MAJOR DIAMETER - 21.81/21.67 PITCH DIAMETER - 20.638
CA	ISO 3019-2: 100B2SW	SAE J744: JUN96 101-2 (B)	SAE J744: JUN96 101-2 (B)
CB	13.8/13.5	14.6/14.2	14.6/14.2
CC	70.0	73.0	73.0
CD	140.0	146.0	146.0
CE	100.00/99.95	101.60/101.55	101.60/101.55
CF	9.5/9.0	9.7/9.2	9.7/9.2
Keyway Width	8.01/7.96	6.40/6.35	N/A

**Pump Installation - P1/PD-045
End Port
“L” or “AM” Control Option**

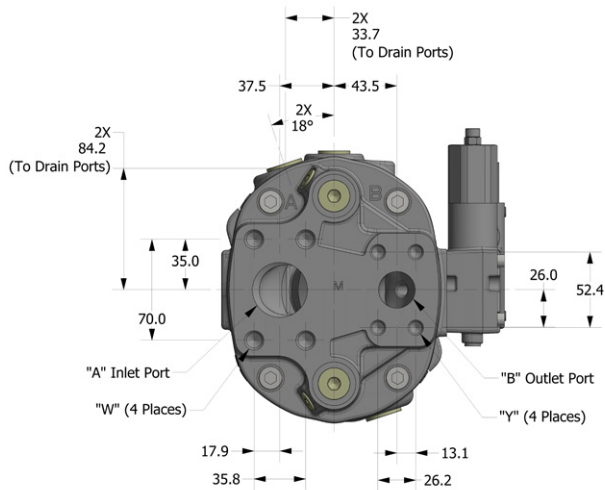
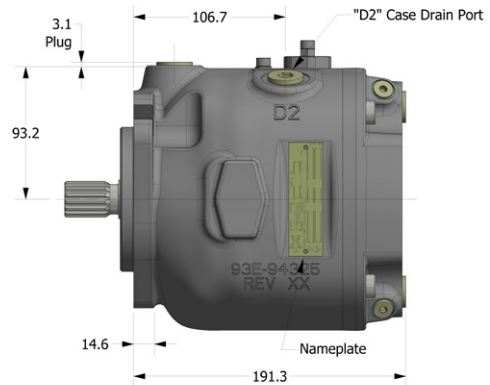
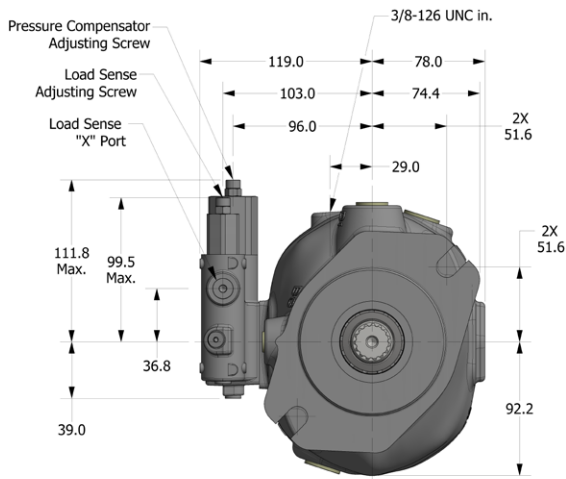
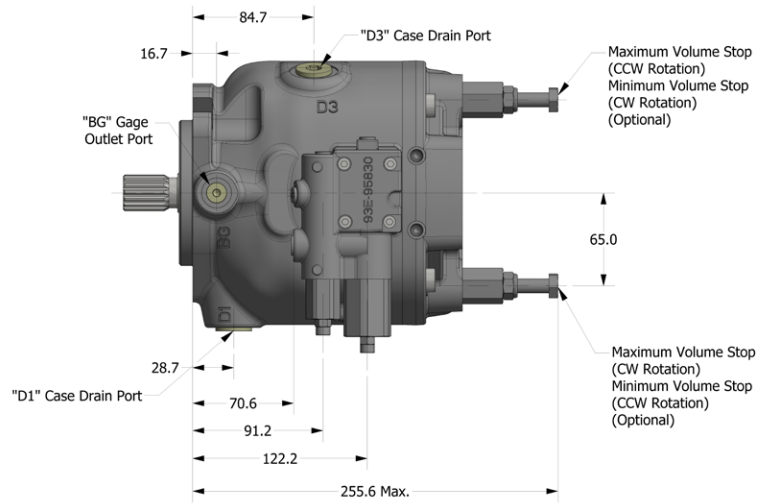

P1/PD-045 Port Sizes					
Ports	SAE Flanged	SAE Threaded	Metric Flanged	Metric Threaded	BSPP
"A" Inlet	1-1/2" Code 61	SAE-24	DN38	M48x2	-
W Threads	1/2-13 UNC-2B	-	M12x1.75-6H	-	-
"B" Outlet	1" Code 61	SAE-16	DN25	M33x2	-
Y Threads	3/8-16 UNC-28	-	M10x1.5-6H	-	-
BG, X	SAE-4		M12x1.5		1/4"
D1, D2, D3	SAE-10		M22x1.5		1/2"

Note A: SAE flanged ports conform to SAE J518
 Note B: SAE o-ring port conforms to SAE 1926
 Note C: Metric flanged ports conform to ISO 6162
 Note D: Metric o-ring boss port conforms to ISO 6149-1
 Note E: BSPP port conforms to ISO 228-1

**Pump Installation - P1/PD-045
Side Port
"L" or "AM" Control Option**

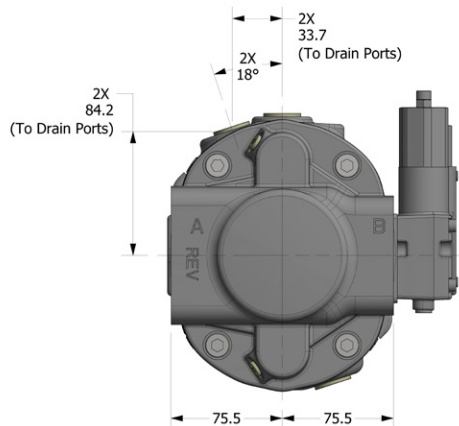
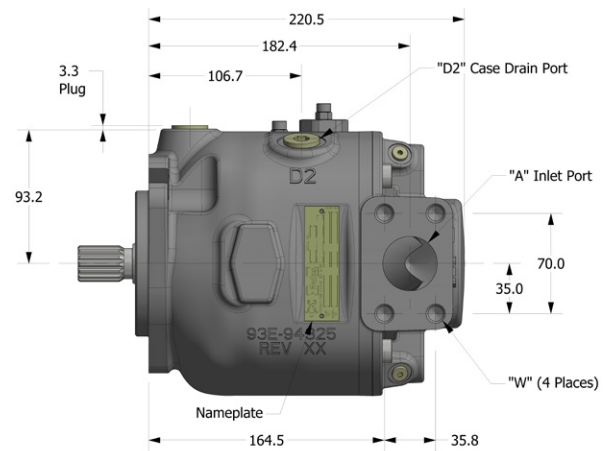
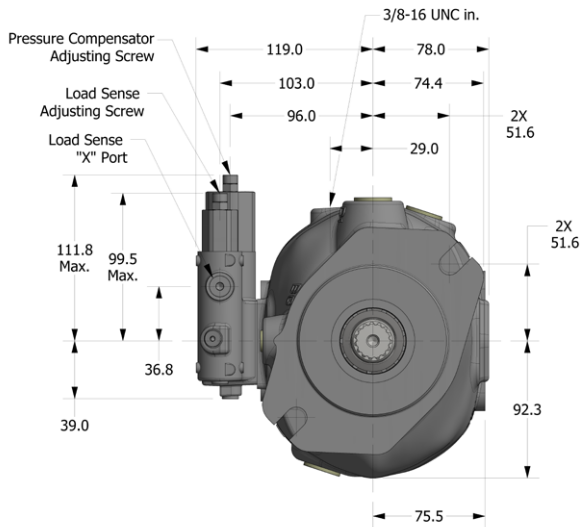
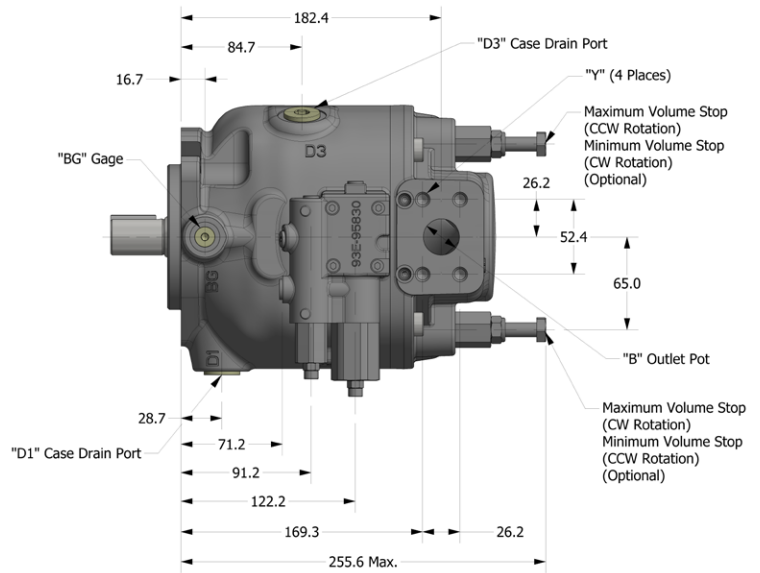

P1/PD-045 Port Sizes					
Ports	SAE Flanged	SAE Threaded	Metric Flanged	Metric Threaded	BSPP
"A" Inlet	1-1/2" Code 61	SAE-24	DN38	M48x2	-
W Threads	1/2-13 UNC-2B	-	M12x1.75-6H	-	-
"B" Outlet	1" Code 61	SAE-16	DN25	M33x2	-
Y Threads	3/8-16 UNC-28	-	M10x1.5-6H	-	-
BG, X	SAE-4		M12x1.5		1/4"
D1, D2, D3	SAE-10		M22x1.5		1/2"

Note A: SAE flanged ports conform to SAE J518
 Note B: SAE o-ring port conforms to SAE 1926
 Note C: Metric flanged ports conform to ISO 6162
 Note D: Metric o-ring boss port conforms to ISO 6149-1
 Note E: BSPP port conforms to ISO 228-1

**Pump Installation - P1/PD-045
Side Ports with Thru-Drive
“L” or “AM” Control Option**

P1/PD-045 Port Sizes					
	SAE Flanged	SAE Threaded	Metric Flanged	Metric Threaded	BSPB
"A" Inlet	1-1/2" Code 61	SAE-24	DN38	M48x2	-
W Threads	1/2-13 UNC-2B	-	M12x1.75-6H	-	-
"B" Outlet	1" Code 61	SAE-16	DN25	M33x2	-
Y Threads	3/8-16 UNC-28	-	M10x1.5-6H	-	-
BG, X	SAE-4		M12x1.5		1/4"
D1, D2, D3	SAE-10		M22x1.5		1/2"

Note A: SAE flanged ports conform to SAE J518
 Note B: SAE o-ring port conforms to SAE 1926
 Note C: Metric flanged ports conform to ISO 6162
 Note D: Metric o-ring boss port conforms to ISO 6149-1
 Note E: BSPP port conforms to ISO 228-1

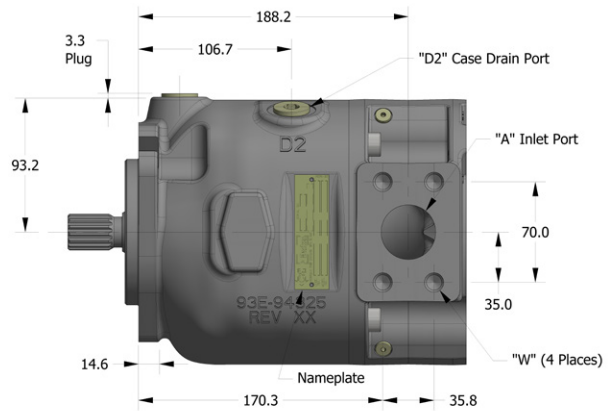
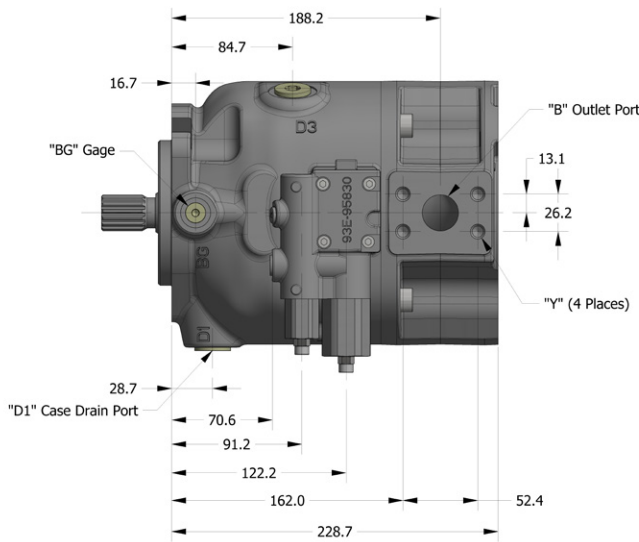

Thru-Drive Mounting Options

SAE-A Mounting Options Information	
Model Number T0*A Spline: ANSI B92.1 1996 SAE 16-4 (A) Involute Spline Class 7 Flat Root Side Fit Number of Teeth - 9 Pitch - 16/32 Pressure Angle - 30° Major Diameter - 13.06/12.93 mm Pitch Diameter - 14.29 mm	Model Number T0*H Spline: ANSI B92.1 1996 SAE 19-4 Involute Spline Class 7 Flat Root Side Fit Number of Teeth - 11 Pitch - 16/32 Pressure Angle - 30° Minor Diameter - 16.14/16.02 mm Pitch Diameter - 17.46 mm

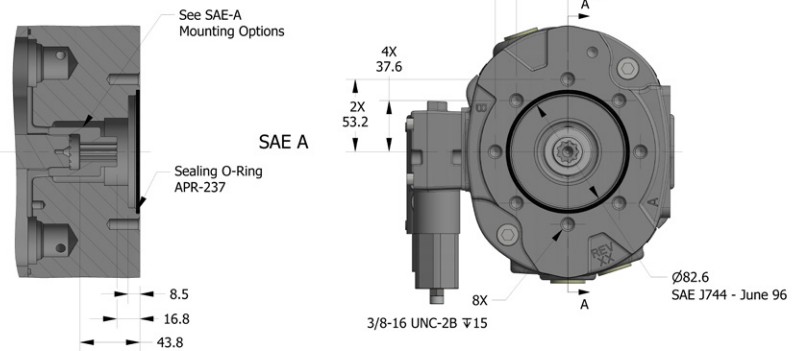

SAE-B Mounting Options Information	
Model Number T0*B Spline: ANSI B92.1 1996 SAE 22-4 (B) Involute Spline Class 7 Flat Root Side Fit Number of Teeth - 13 Pitch - 16/32 Pressure Angle - 30° Minor Diameter - 19.28/19.15 mm Pitch Diameter - 20.64 mm	Model Number T0*Q Spline: ANSI B92.1 1996 SAE 25-4 (B-B) Involute Spline Class 7 Flat Root Side Fit Number of Teeth - 15 Pitch - 16/32 Pressure Angle - 30° Minor Diameter - 22.40/22.28 mm Pitch Diameter - 23.81 mm

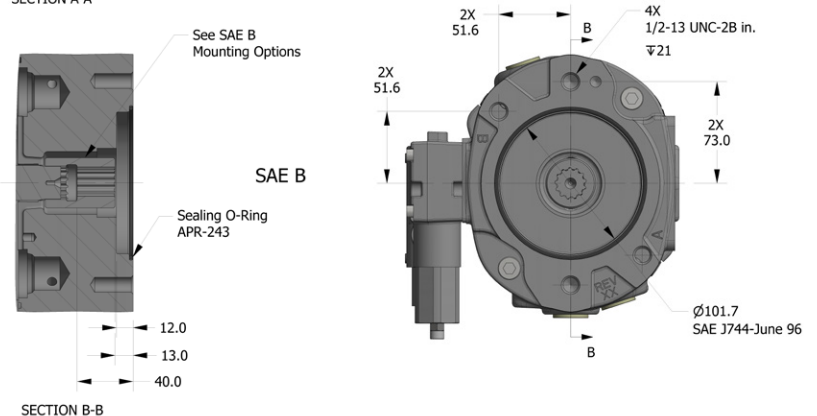

**Pump Installation - P1/PD-060
Input Shaft Dimensions**

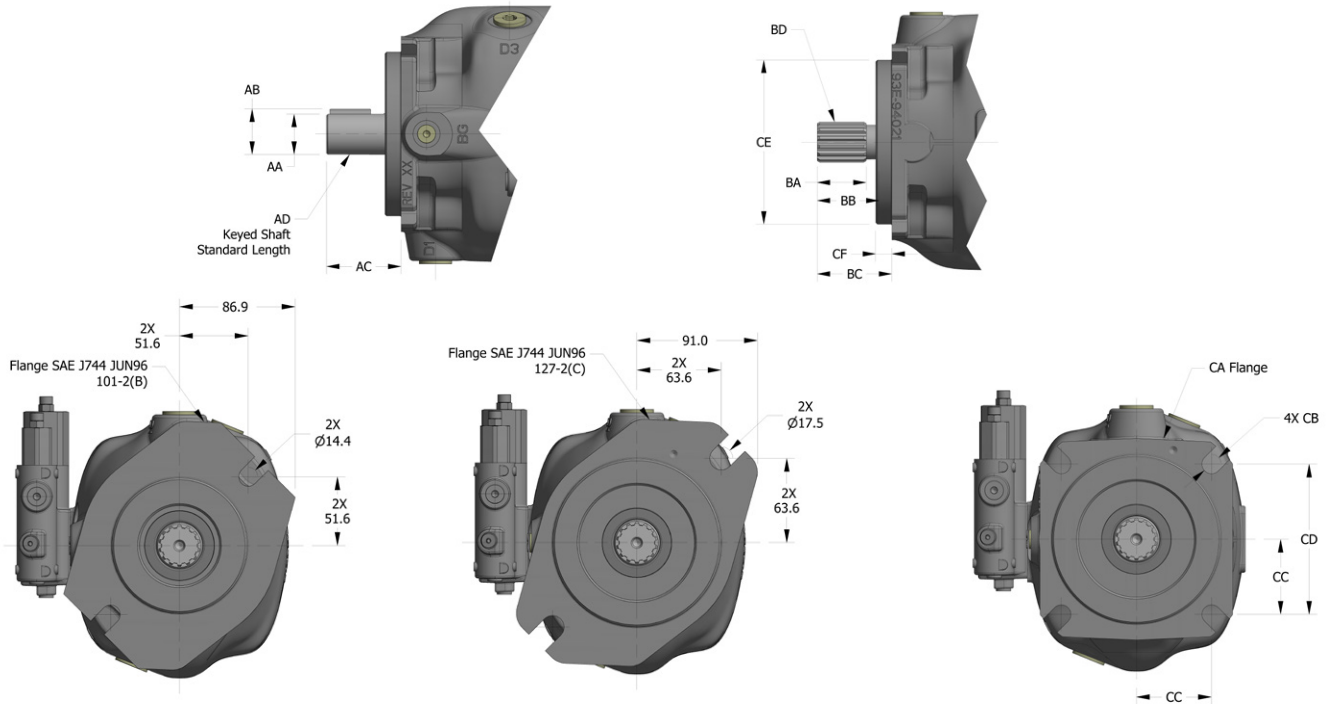

P1/PD-060 Mounting Flange & Shaft Dimensions				
Dimension	ISO (Code 04)	SAE (Code 01 or 02)	SAE (Code 09)	SAE (Code 10)
AA	32.03/32.00	31.75/31.70	N/A	N/A
AB	35.00/34.71	35.33/35.07	N/A	N/A
AC	67.0	56.0	N/A	N/A
AD	ISO 3019-2: E32N	SAE J744 32-1 (C)	N/A	N/A
BA	N/A	36.0	26.0	15.5
BB	N/A	48.0	38.0	33.0
BC	N/A	56.0	46.0	41.0
BD	N/A	SPLINE: ASA B5.15-1960 SAE 32-4 (C) INVOLUTE SPLINE CLASS 2 FLAT ROOT SIDE FIT NUMBER OF TEETH - 14 PITCH - 12/24 PRESSURE ANGLE - 30° MAJOR DIAMETER - 31.22/31.09 PITCH DIAMETER - 29.634	SPLINE: ANSI B92.1-1996 SAE 25-4 (B-B) INVOLUTE SPLINE CLASS 7 FLAT ROOT SIDE FIT NUMBER OF TEETH - 15 PITCH - 16/32 PRESSURE ANGLE - 30° MAJOR DIAMETER - 25.00/24.84 PITCH DIAMETER - 23.813	SPLINE: ANSI B92.1-1996 SAE 22-4 (B) INVOLUTE SPLINE CLASS 7 FLAT ROOT SIDE FIT NUMBER OF TEETH - 13 PITCH - 16/32 PRESSURE ANGLE - 30° MAJOR DIAMETER - 22.23/21.67 PITCH DIAMETER - 20.638
CA	ISO 3019-2: 125B4SW	SAE J744: JUN 96 127-4 (C)	SAE J744: JUN96 101-2 (B)	SAE J744: JUN96 101-2 (B)
CB	13.8/13.5	14.6/14.2	14.6/14.2	14.6/14.2
CC	56.6	56.8	N/A	N/A
CD	113.1 square	113.5 square	N/A	N/A
CE	125.00/124.94	127.00/126.95	101.60/101.55	101.60/101.55
CF	9.5/9.0	12.7/12.2	9.7/9.2	9.7/9.2
Keyway Width	10.01/9.96	8.00/7.95	N/A	N/A

**Pump Installation - P1/PD-060
End Port
“L” or “AM” Control Option**

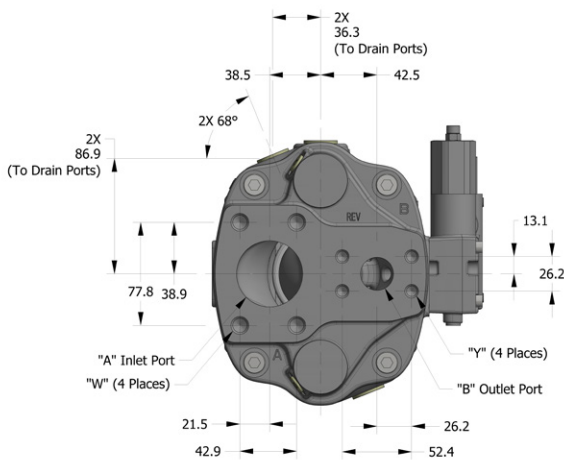
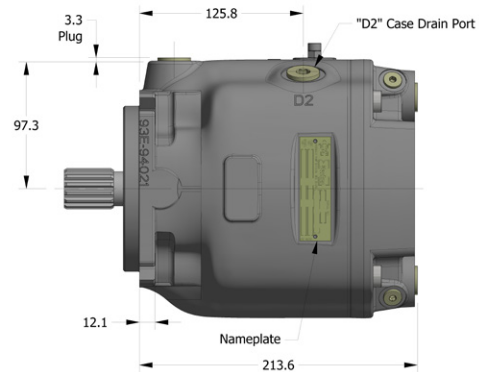
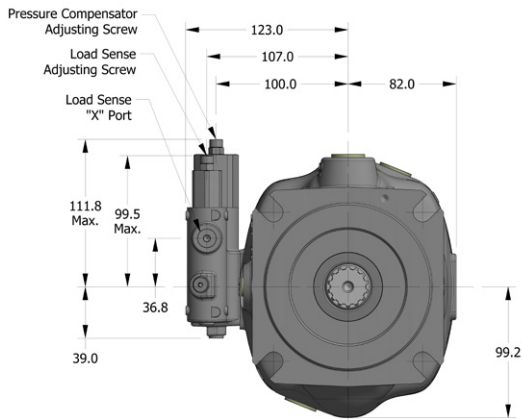
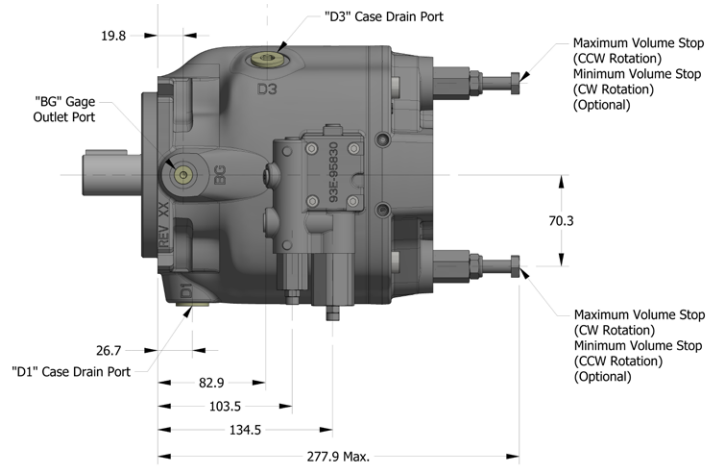

P1/PD-060 Port Sizes				
Ports	SAE Flanged	SAE Threaded	Metric Flanged	BSPP
"A" Inlet	2" Code 61	2-1/2-12 UNF-2B	DN51	2"
W Threads	1/2-13 UNC-2B	-	M12x1.75-6H	-
"B" Outlet	1" Code 61	1-5/8-12 UNF-2B	DN25	1-1/4"
Y Threads	3/8-16 UNC-28	-	M10x1.5-6H	-
BG, X	SAE-4		M12x1.5	1/4"
D1, D2, D3	SAE-10		M22x1.5	3/4"

Note A: SAE flanged ports conform to SAE J518
 Note B: SAE o-ring port conforms to SAE 1926
 Note C: Metric flanged ports conform to ISO 6162
 Note D: Metric o-ring boss port conforms to ISO 6149-1
 Note E: BSPP port conforms to ISO 228-1

*Cannot use standard SAE Code 61 split flanges with the end ported option



**Pump Installation - P1/PD-060
Side Port
“L” or “AM” Control Option**

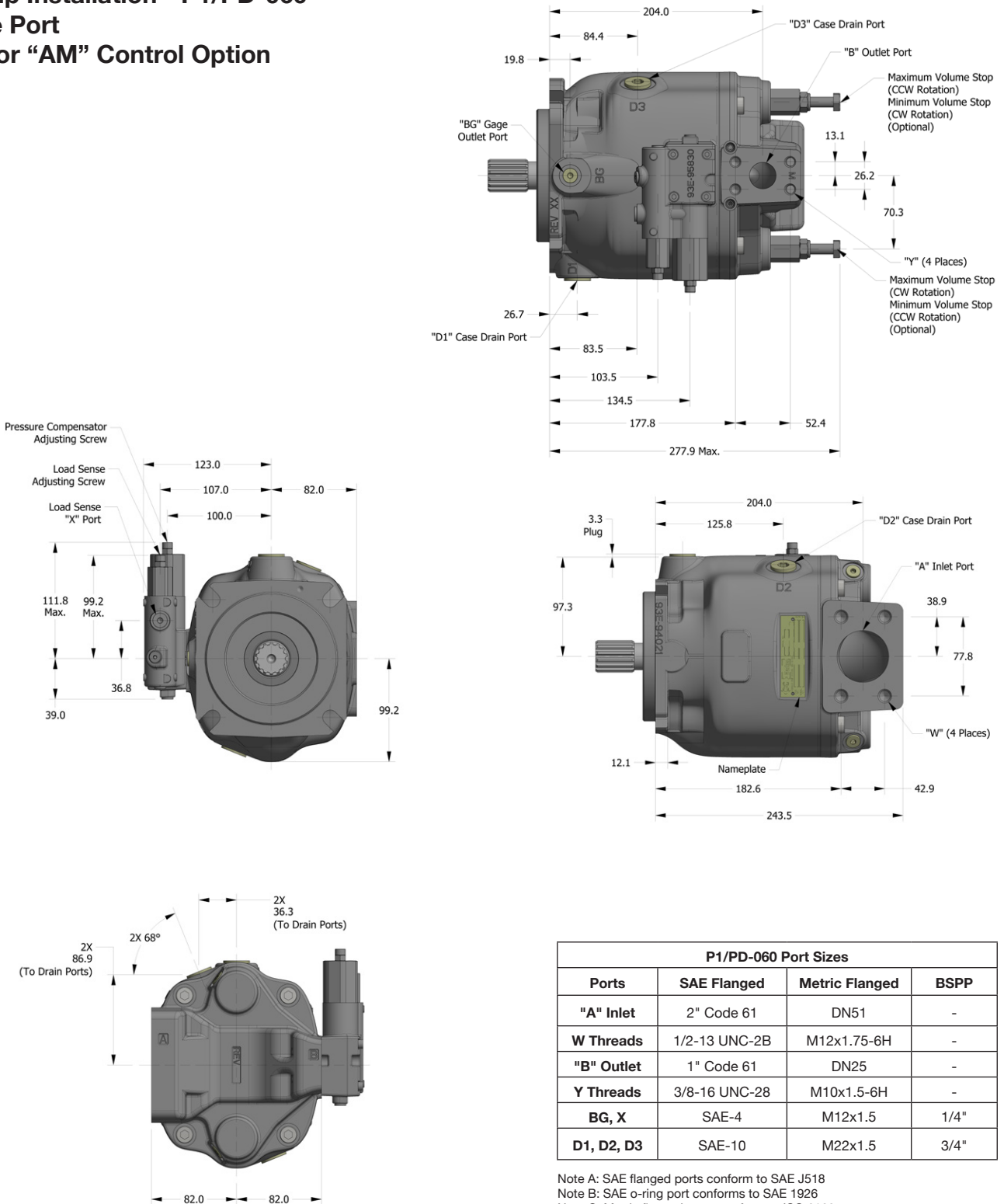

Note A: SAE flanged ports conform to SAE J518
 Note B: SAE o-ring port conforms to SAE 1926
 Note C: Metric flanged ports conform to ISO 6162
 Note D: Metric o-ring boss port conforms to ISO 6149-1
 Note E: BSPP port conforms to ISO 228-1



**Pump Installation - P1/PD-060
Side Ports with Thru-Drive
“L” or “AM” Control Option**

P1/PD-060 Port Sizes			
Ports	SAE Flanged	Metric Flanged	BSPP
"A" Inlet	2" Code 61	DN51	-
W Threads	1/2-13 UNC-2B	M12x1.75-6H	-
"B" Outlet	1" Code 61	DN25	-
Y Threads	3/8-16 UNC-28	M10x1.5-6H	-
BG, X	SAE-4	M12x1.5	1/4"
D1, D2, D3	SAE-10	M22x1.5	3/4"

Note A: SAE flanged ports conform to SAE J518
 Note B: SAE o-ring port conforms to SAE 1926
 Note C: Metric flanged ports conform to ISO 6162
 Note D: Metric o-ring boss port conforms to ISO 6149-1
 Note E: BSPP port conforms to ISO 228-1

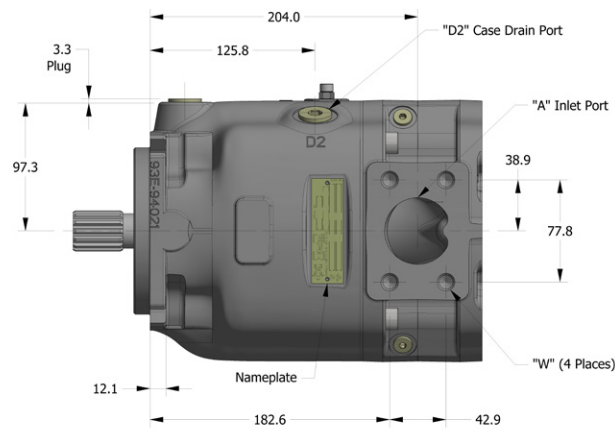
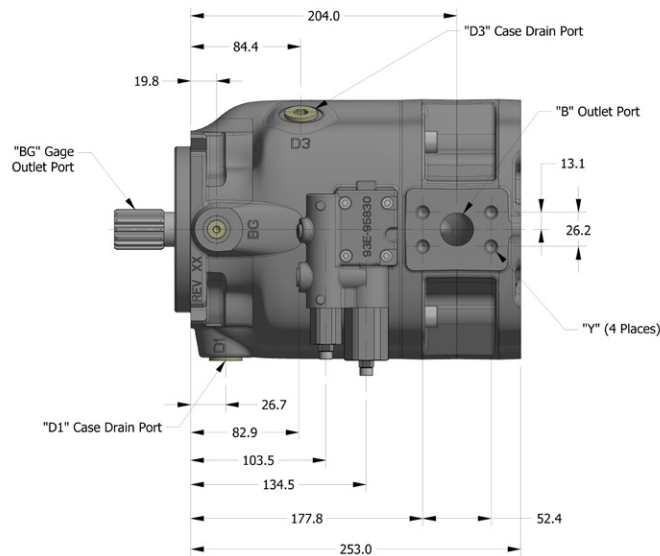

**Pump Installation - P1/PD-060
Side Ports with Thru-Drive
Mounting Options**

SAE-A

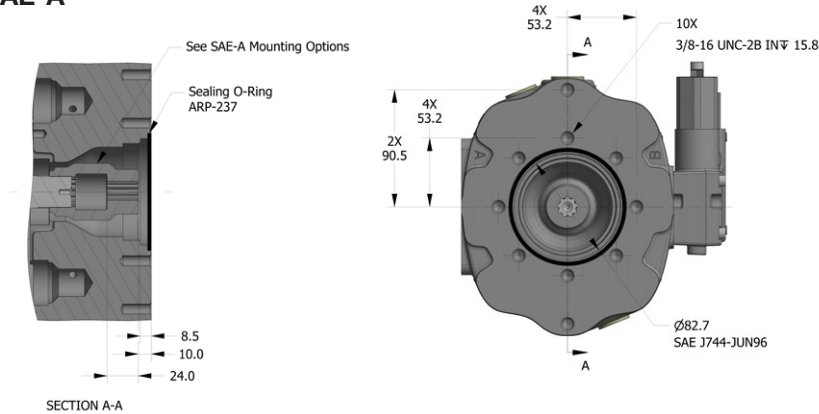

SAE-A Mounting Options Information	
Model Number	T0*A
Spline:	ANSI B92.1 1996
SAE	16-4 (A) Involute Spline
Class	7 Flat Root Side Fit
Number of Teeth	- 9
Pitch	- 16/32
Pressure Angle	- 30°
Major Diameter	- 13.06/12.93 mm
Pitch Diameter	- 14.29 mm
Model Number	T0*H
Spline:	ANSI B92.1 1996
SAE	19-4 Involute Spline
Class	7 Flat Root Side Fit
Number of Teeth	- 11
Pitch	- 16/32
Pressure Angle	- 30°
Minor Diameter	- 16.14/16.02 mm
Pitch Diameter	- 17.46 mm

SAE-B

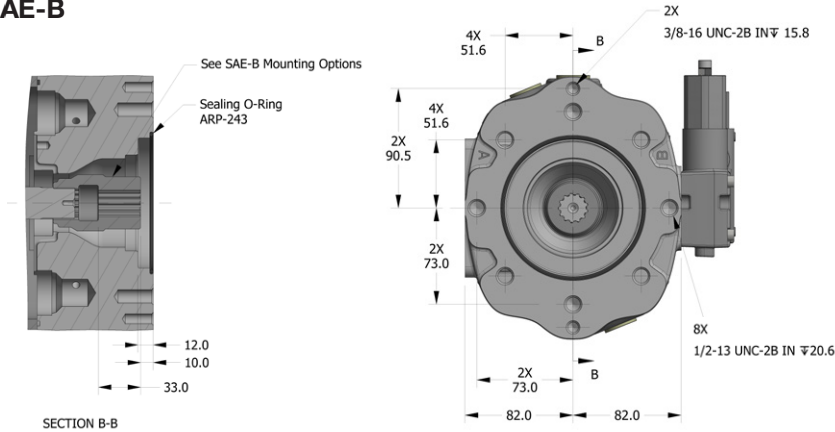

SAE-B Mounting Options Information	
Model Number	T0*B
Spline:	ANSI B92.1 1996
SAE	22-4 (B) Involute Spline
Class	7 Flat Root Side Fit
Number of Teeth	- 13
Pitch	- 16/32
Pressure Angle	- 30°
Minor Diameter	- 19.28/19.15 mm
Pitch Diameter	- 20.64 mm
Model Number	T0*Q
Spline:	ANSI B92.1 1996
SAE	25-4 (B-B) Involute Spline
Class	7 Flat Root Side Fit
Number of Teeth	- 15
Pitch	- 16/32
Pressure Angle	- 30°
Minor Diameter	- 22.40/22.28 mm
Pitch Diameter	- 23.81 mm

SAE-C

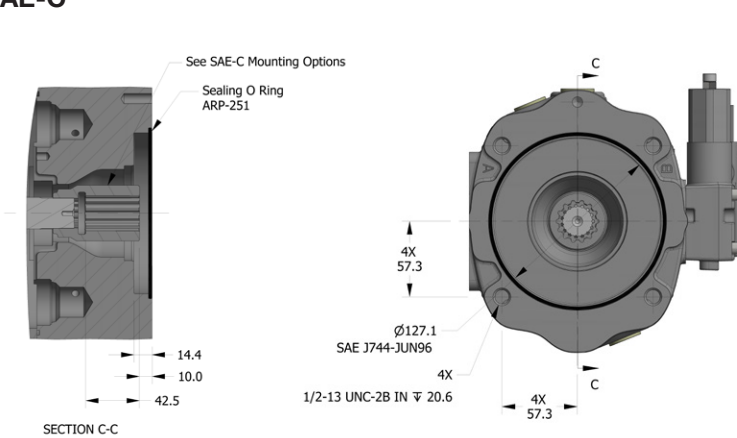

SAE-C Mounting Options Information	
Model Number	T0*C
Spline:	ANSI B92.1 1996
SAE	32-4 (C) Involute Spline
Class	2 Flat Root Side Fit
Number of Teeth	- 14
Pitch	- 12/24
Pressure Angle	- 30°
Minor Diameter	- 27.74/27.61 mm
Pitch Diameter	- 29.63 mm

**Pump Installation - P1/PD-075 & 085
Input Shafts**

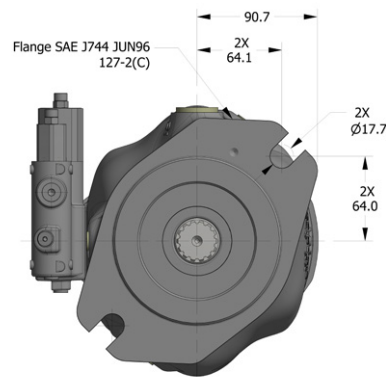
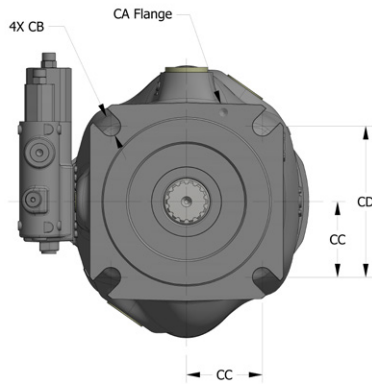
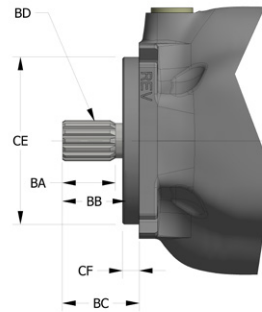
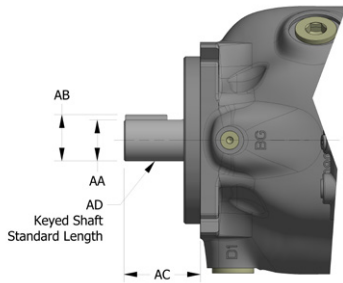

P1/PD-075 & 085 Mounting Flange & Shaft Dimensions		
Dimension	ISO (Code 04)	SAE (Code 01 or 02)
AA	32.03/32.00	31.75/31.70
AB	35.00/34.71	35.33/35.07
AC	68.0	56.0
AD	ISO 3019-2: E32N	SAE J744 32-1 (C)
BA	N/A	36.0
BB	N/A	48.0
BC	N/A	56.0
BD	N/A	SPLINE: ASA B5.15-1960 SAE 32-4 (C) INVOLUTE SPLINE CLASS 1 FLAT ROOT SIDE FIT NUMBER OF TEETH - 14 PITCH - 12/24 PRESSURE ANGLE - 30° MAJOR DIAMETER - 31.22/31.09 PITCH DIAMETER - 29.634
CA	ISO 3019-2: 125B4SW	SAE J744: JUN 96 127-4 (C)
CB	13.8/13.5	14.6/14.2
CC	56.6	56.8
CD	113.1 square	113.5 square
CE	125.00/124.95	127.00/126.95
CF	9.5/9.0	12.7/12.2
Keyway Width	10.01/9.96	8.00/7.95

Pump Installation - P1/PD-075 & 085

End Port

“L” or “AM” Control Option

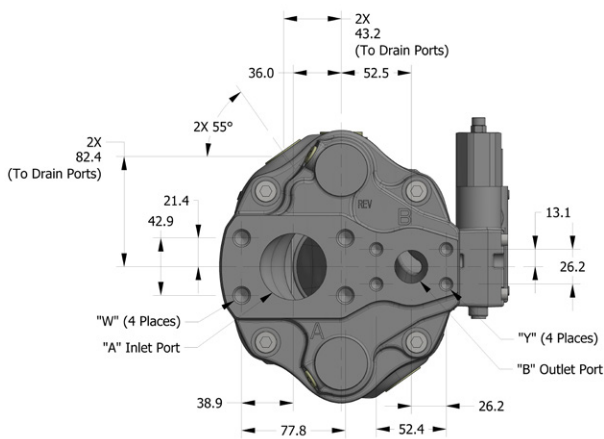
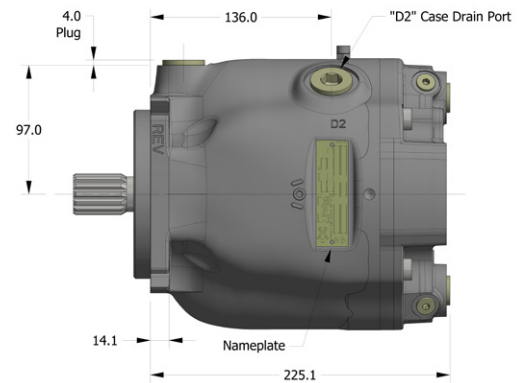
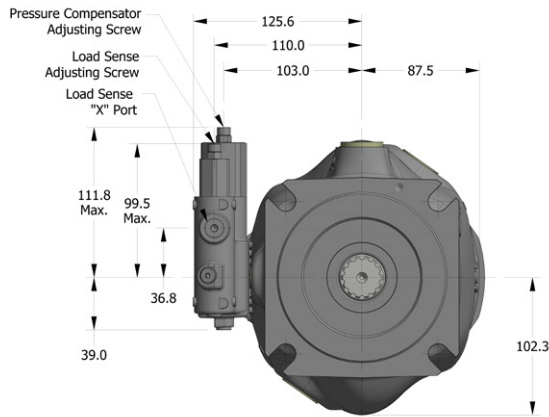
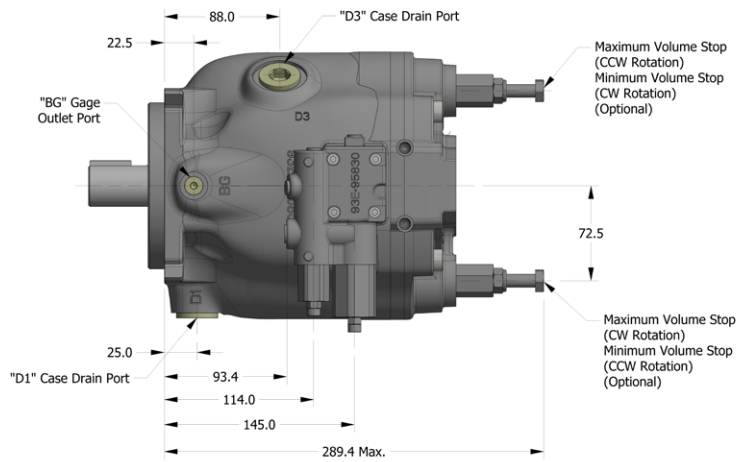

P1/PD-075 & 085 Port Sizes			
Ports	SAE Flanged	Metric Flanged	BSPP
"A" Inlet	2" Code 61	DN51	-
W Threads	1/2-13 UNC-2B	M12x1.75-6H	-
"B" Outlet	1" Code 61	DN25	-
Y Threads	3/8-16 UNC-28	M10x1.5-6H	-
BG, X	SAE-4	M12x1.5	1/4"
D1, D2, D3	SAE-12	M27x2	3/4"

Note A: SAE flanged ports conform to SAE J518
 Note B: SAE o-ring port conforms to SAE 1926
 Note C: Metric flanged ports conform to ISO 6162
 Note D: Metric o-ring boss port conforms to ISO 6149-1
 Note E: BSPP port conforms to ISO 228-1

Pump Installation - P1/PD-075 & 085
Side Port
“L” or “AM” Control Option

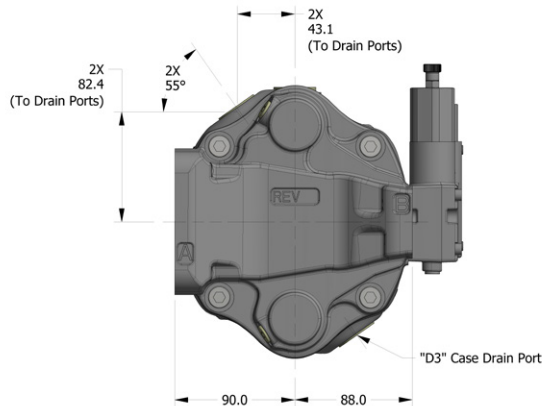
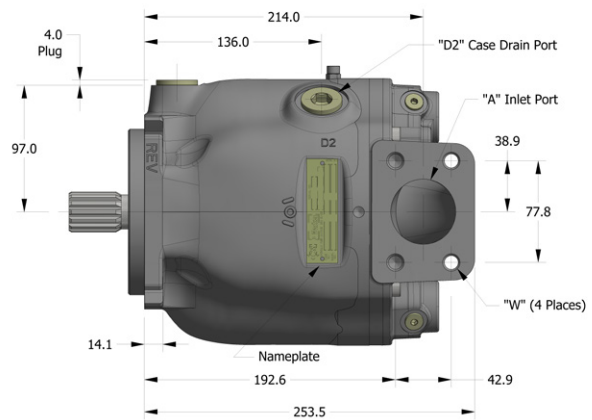
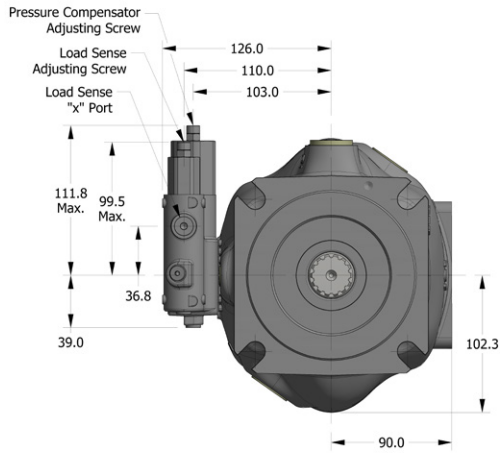
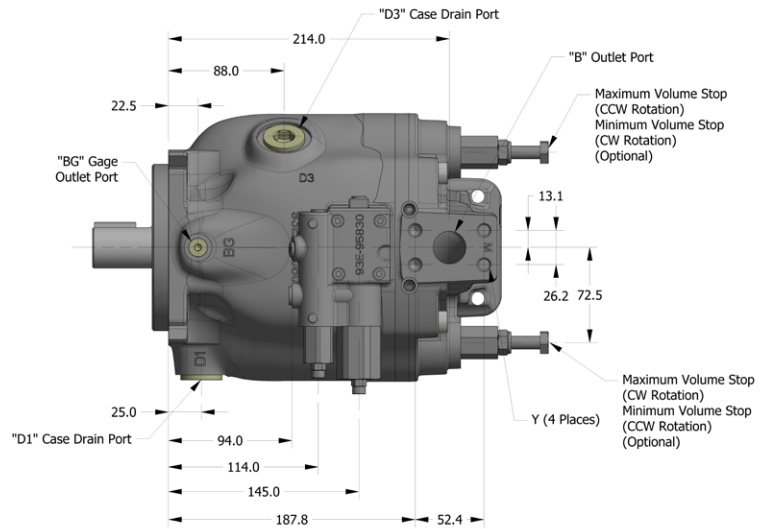

P1/PD-075 & 085 Port Sizes			
Ports	SAE Flanged	Metric Flanged	BSPP
"A" Inlet	2" Code 61	DN51	-
W Threads	1/2-13 UNC-2B	M12x1.75-6H	-
"B" Outlet	1" Code 61	DN25	-
Y Threads	3/8-16 UNC-28	M10x1.5-6H	-
BG, X	SAE-4	M12x1.5	1/4"
D1, D2, D3	SAE-12	M27x2	3/4"

Note A: SAE flanged ports conform to SAE J518
 Note B: SAE o-ring port conforms to SAE 1926
 Note C: Metric flanged ports conform to ISO 6162
 Note D: Metric o-ring boss port conforms to ISO 6149-1
 Note E: BSPP port conforms to ISO 228-1

**Pump Installation - P1/PD-075 & 085
Side Ports with Thru-Drive
“L” or “AM” Control Option**

P1/PD-075 & 085 Port Sizes			
Ports	SAE Flanged	Metric Flanged	BSPP
"A" Inlet	2" Code 61	DN51	-
W Threads	1/2-13 UNC-2B	M12x1.75-6H	-
"B" Outlet	1" Code 61	DN25	-
Y Threads	3/8-16 UNC-28	M10x1.5-6H	-
BG, X	SAE-4	M12x1.5	1/4"
D1, D2, D3	SAE-12	M27x2	3/4"

Note A: SAE flanged ports conform to SAE J518
 Note B: SAE o-ring port conforms to SAE 1926
 Note C: Metric flanged ports conform to ISO 6162
 Note D: Metric o-ring boss port conforms to ISO 6149-1
 Note E: BSPP port conforms to ISO 228-1

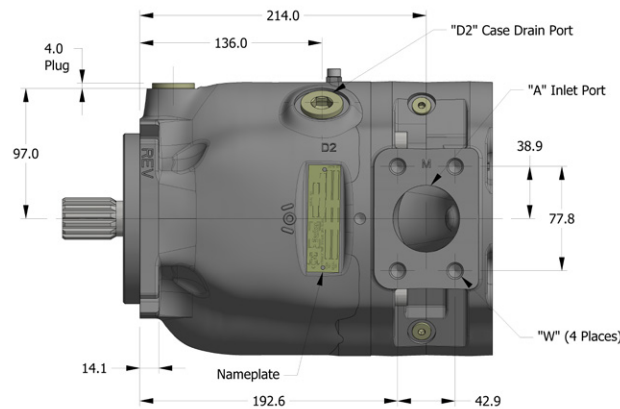
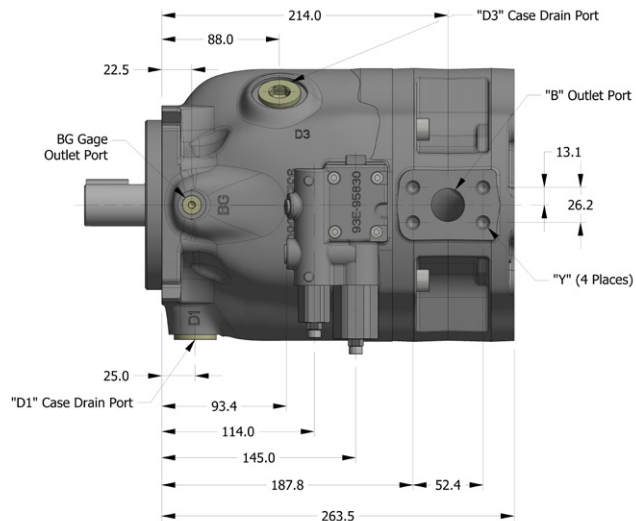

**Pump Installation - P1/PD-075 & 085
Side Ports with Thru-Drive
Mounting Options**

SAE-A

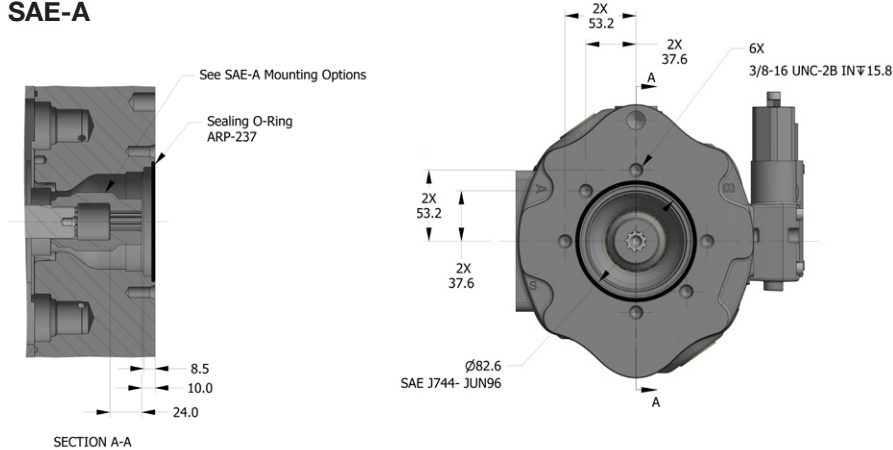

SAE-A Mounting Options Information	
Model Number	T0*A
Spline:	ANSI B92.1 1996
SAE	16-4 (A) Involute Spline
	Class 5 Flat Root Side Fit
Number of Teeth	- 9
Pitch	- 16/32
Pressure Angle	- 30°
Major Diameter	- 13.06/12.93 mm
Pitch Diameter	- 14.29 mm
Model Number	T0*H
Spline:	ANSI B92.1 1996
SAE	19-4 Involute Spline
	Class 5 Flat Root Side Fit
Number of Teeth	- 11
Pitch	- 16/32
Pressure Angle	- 30°
Minor Diameter	- 16.14/16.02 mm
Pitch Diameter	- 17.46 mm

SAE-B

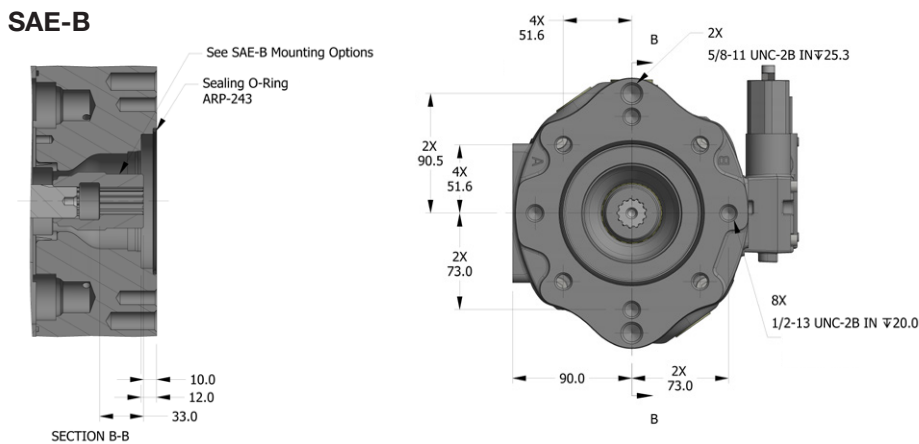

SAE-B Mounting Options Information	
Model Number	T0*B
Spline:	ANSI B92.1 1996
SAE	22-4 (B) Involute Spline
	Class 5 Flat Root Side Fit
Number of Teeth	- 13
Pitch	- 16/32
Pressure Angle	- 30°
Minor Diameter	- 19.28/19.15 mm
Pitch Diameter	- 20.64 mm
Model Number	T0*Q
Spline:	ANSI B92.1 1996
SAE	25-4 (B-B) Involute Spline
	Class 5 Flat Root Side Fit
Number of Teeth	- 15
Pitch	- 16/32
Pressure Angle	- 30°
Minor Diameter	- 22.40/22.28 mm
Pitch Diameter	- 23.81 mm

SAE-C

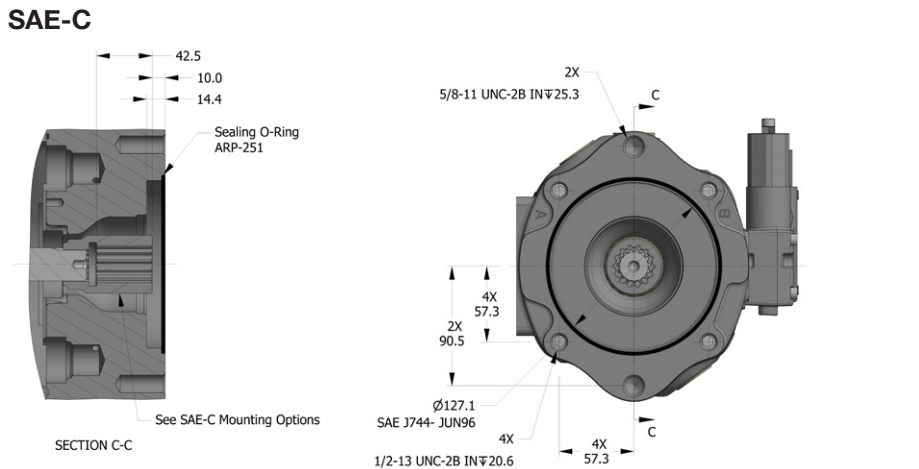

SAE-C Mounting Options Information	
Model Number	T0*C
Spline:	ANSI B92.1 1996
SAE	32-4 (C) Involute Spline
	Class 1 Flat Root Side Fit
Number of Teeth	- 14
Pitch	- 12/24
Pressure Angle	- 30°
Minor Diameter	- 27.74/27.61 mm
Pitch Diameter	- 29.63 mm

**Pump Installation - P1/PD-100
Input Shafts**

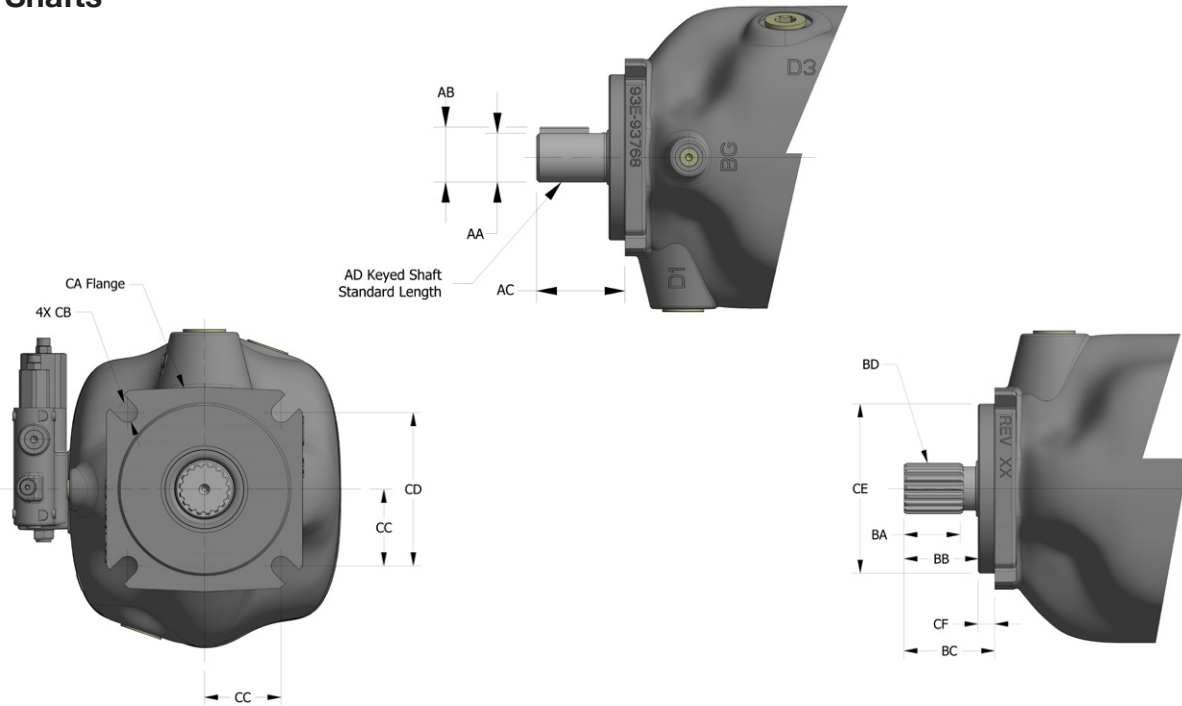

P1/PD-100 Mounting Flange & Shaft Dimensions			
Dimension	ISO (Code 04)	SAE (Code 01 or 02)	SAE (Code 06)
AA	40.03/40.00	38.10/38.05	N/A
AB	43.00/42.71	42.35/42.17	N/A
AC	92.6	62.3	N/A
AD	ISO 3019-2: E40N	SAE J744 38-1 (C-C)	N/A
BA	N/A	42.1	38.0
BB	N/A	54.0	48.0
BC	N/A	62.3	56.0
BD	N/A	SPLINE: ASA-B5.15-1960 SAE 38-4 (C-C) INVOLUTE SPLINE CLASS 1 FLAT ROOT SIDE FIT NUMBER OF TEETH - 17 PITCH - 12/24 PRESSURE ANGLE - 30 MAJOR DIAMETER - 37.57/37.44 PITCH DIAMETER - 35.984	SPLINE: ASA-B5.15-1960 SAE 32-4 (C) INVOLUTE SPLINE CLASS 1 FLAT ROOT SIDE FIT NUMBER OF TEETH - 14 PITCH - 12/24 PRESSURE ANGLE - 30 MAJOR DIAMETER - 31.22/31.09 PITCH DIAMETER - 29.634
CA	ISO 3019-2: 125B4SW	SAE J744: JUN 96 127-4 (C)	SAE 744: JUN 96 127-4 (C)
CB	13.8/13.5	14.6/14.2	14.6/14.2
CC	56.6	56.8	56.8
CD	113.1 square	113.5 square	113.5 square
CE	125.00/124.95	127.00/126.95	127.00/126.95
CF	9.5/9.0	12.7/12.2	12.7/12.2
Keyway Width	12.01/11.96	9.58/9.53	8.00/7.95

Pump Installation - P1/PD-100
End Ports
“L” or “AM” Control Option

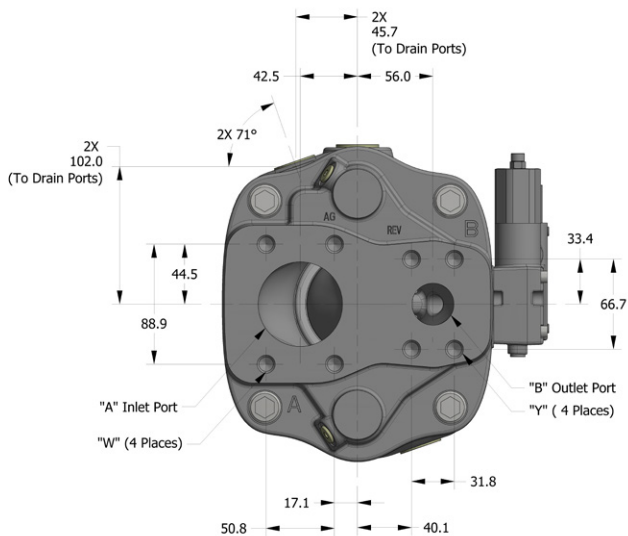
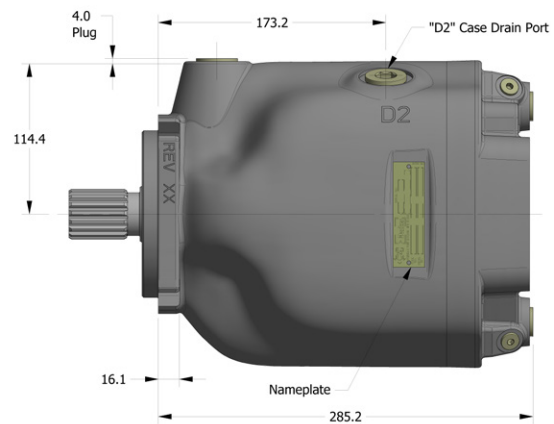
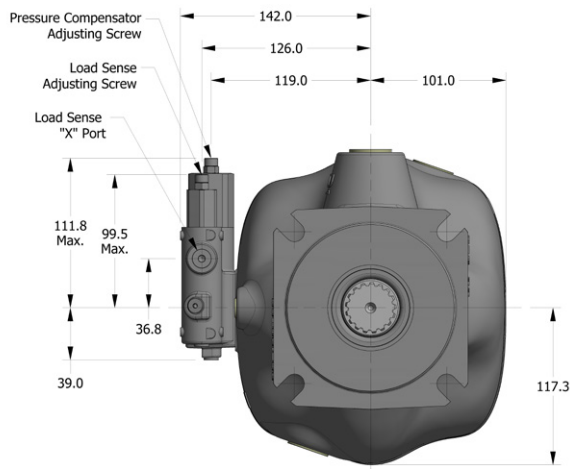
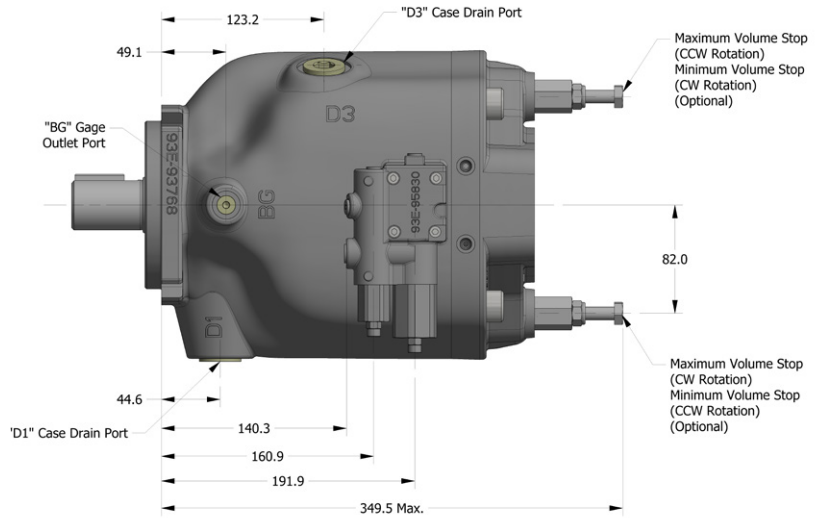

P1/PD-100 Port Sizes			
Ports	SAE Flanged	Metric Flanged	BSPP
"A" Inlet	2-1/2" Code 61	DN63	-
W Threads	1/2-13 UNC-2B	M12x1.75-6H	-
"B" Outlet	1-1/4" Code 62	DN32	-
Y Threads	1/2-13 UNC-28	M12x1.75-6H	-
BG, X	SAE-4	M12x1.5	1/4"
D1, D2, D3	SAE-12	M27x2	3/4"

Note A: SAE flanged ports conform to SAE J518
 Note B: SAE o-ring port conforms to SAE 1926
 Note C: Metric flanged ports conform to ISO 6162
 Note D: Metric o-ring boss port conforms to ISO 6149-1
 Note E: BSPP port conforms to ISO 228-1

**Pump Installation - P1/PD-100
Side Ports
“L” or “AM” Control Option**

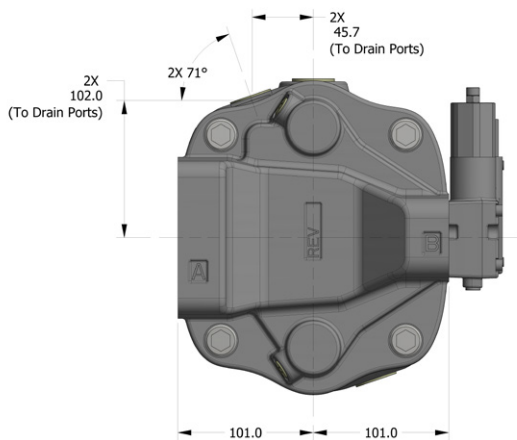
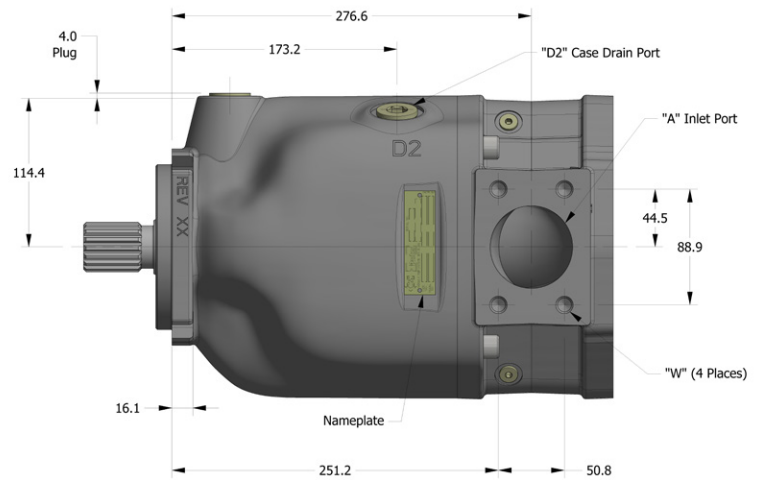
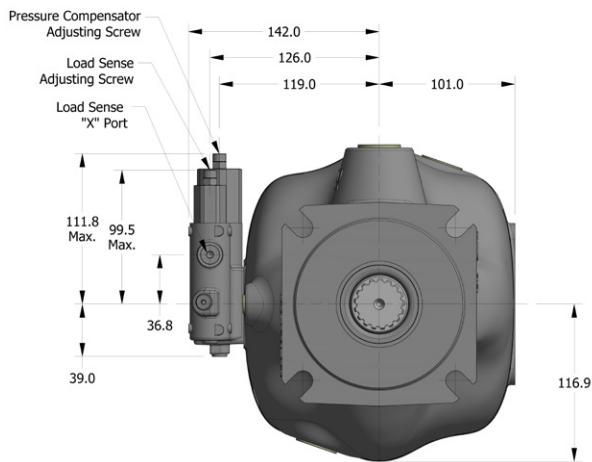
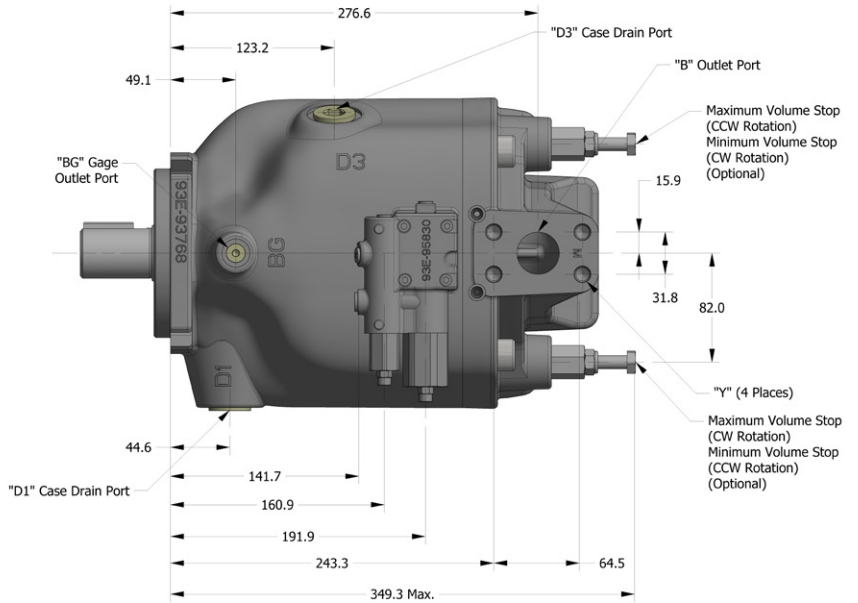

P1/PD-100 Port Sizes			
Ports	SAE Flanged	Metric Flanged	BSPP
"A" Inlet	2-1/2" Code 61	DN63	-
W Threads	1/2-13 UNC-2B	M12x1.75-6H	-
"B" Outlet	1-1/4" Code 62	DN32	-
Y Threads	1/2-13 UNC-28	M12x1.75-6H	-
BG, X	SAE-4	M12x1.5	1/4"
D1, D2, D3	SAE-12	M27x2	3/4"

Note A: SAE flanged ports conform to SAE J518
 Note B: SAE o-ring port conforms to SAE 1926
 Note C: Metric flanged ports conform to ISO 6162
 Note D: Metric o-ring boss port conforms to ISO 6149-1
 Note E: BSPP port conforms to ISO 228-1

**Pump Installation - P1/PD-100
Side Ports with Thru-Drive
“L” or “AM” Control Option**

P1/PD-100 Port Sizes			
Ports	SAE Flanged	Metric Flanged	BSPP
"A" Inlet	2-1/2" Code 61	DN63	-
W Threads	1/2-13 UNC-2B	M12x1.75-6H	-
"B" Outlet	1-1/4" Code 62	DN32	-
Y Threads	1/2-13 UNC-28	M12x1.75-6H	-
BG, X	SAE-4	M12x1.5	1/4"
D1, D2, D3	SAE-12	M27x2	3/4"

Note A: SAE flanged ports conform to SAE J518
 Note B: SAE o-ring port conforms to SAE 1926
 Note C: Metric flanged ports conform to ISO 6162
 Note D: Metric o-ring boss port conforms to ISO 6149-1
 Note E: BSPP port conforms to ISO 228-1

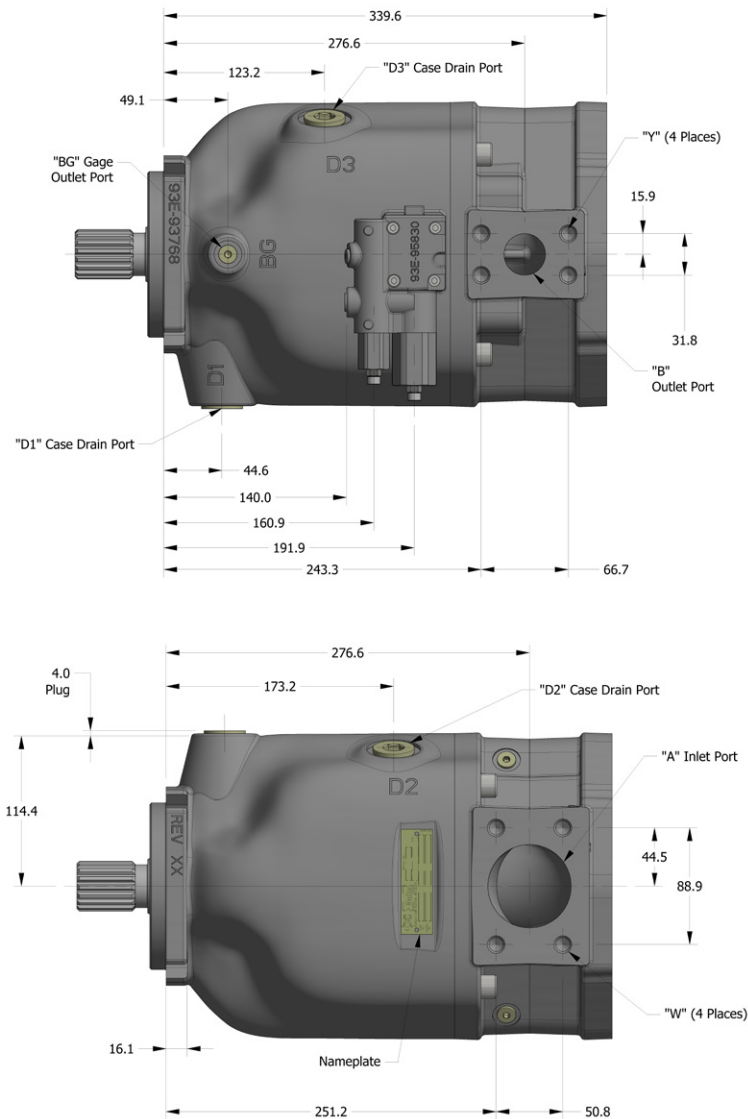

**Pump Installation - P1/PD-100
Side Ports with Thru-Drive
Mounting Options**

SAE-A

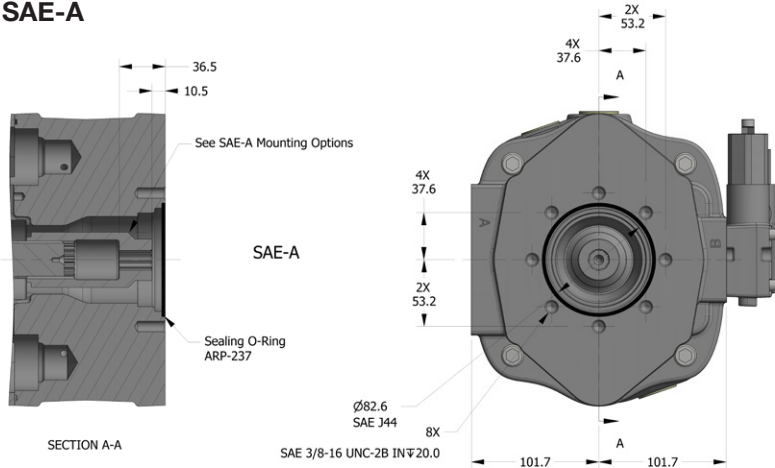

SAE-A Mounting Options Information

Model Number T0*A
Spline: ANSI B92.1 1996
SAE 16-4 (A) Involute Spline
Class 5 Flat Root Side Fit
Number of Teeth - 9
Pitch - 16/32
Pressure Angle - 30°
Major Diameter - 13.06/12.93 mm
Pitch Diameter - 14.29 mm

Model Number T0*H
Spline: ANSI B92.1 1996
SAE 19-4 Involute Spline
Class 5 Flat Root Side Fit
Number of Teeth - 11
Pitch - 16/32
Pressure Angle - 30°
Minor Diameter - 16.14/16.02 mm
Pitch Diameter - 17.46 mm

SAE-B

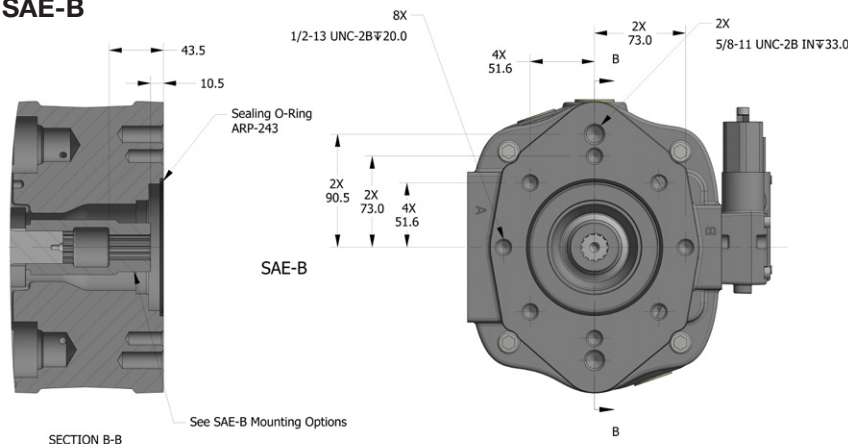

SAE-B Mounting Options Information

Model Number T0*B
Spline: ANSI B92.1 1996
SAE 22-4 (B) Involute Spline
Class 5 Flat Root Side Fit
Number of Teeth - 13
Pitch - 16/32
Pressure Angle - 30°
Minor Diameter - 19.28/19.15 mm
Pitch Diameter - 20.64 mm

Model Number T0*Q
Spline: ANSI B92.1 1996
SAE 25-4 (B-B) Involute Spline
Class 5 Flat Root Side Fit
Number of Teeth - 15
Pitch - 16/32
Pressure Angle - 30°
Minor Diameter - 22.40/22.28 mm
Pitch Diameter - 23.81 mm

SAE-C

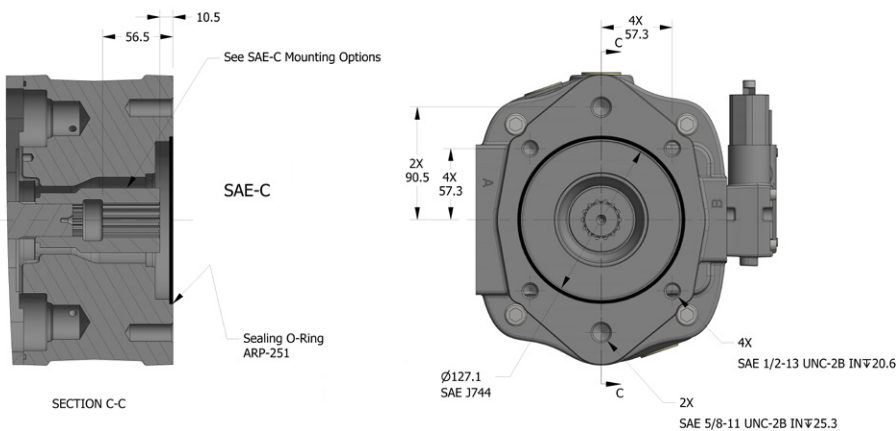

SAE-C Mounting Options Information

Model Number T0*C
Spline: ANSI B92.1 1996
SAE 32-4 (C) Involute Spline
Class 1 Flat Root Side Fit
Number of Teeth - 14
Pitch - 12/24
Pressure Angle - 30°
Minor Diameter - 27.74/27.61 mm
Pitch Diameter - 29.63 mm

Model Number T0*N
Spline: ANSI B92.1 1996
SAE 38-4 (C-C) Involute Spline
Class 1 Flat Root Side Fit
Number of Teeth - 17
Pitch - 12/24
Pressure Angle - 30°
Minor Diameter - 34.01/33.88 mm
Pitch Diameter - 35.98 mm

**Pump Installation - P1/PD-140
Input Shafts**

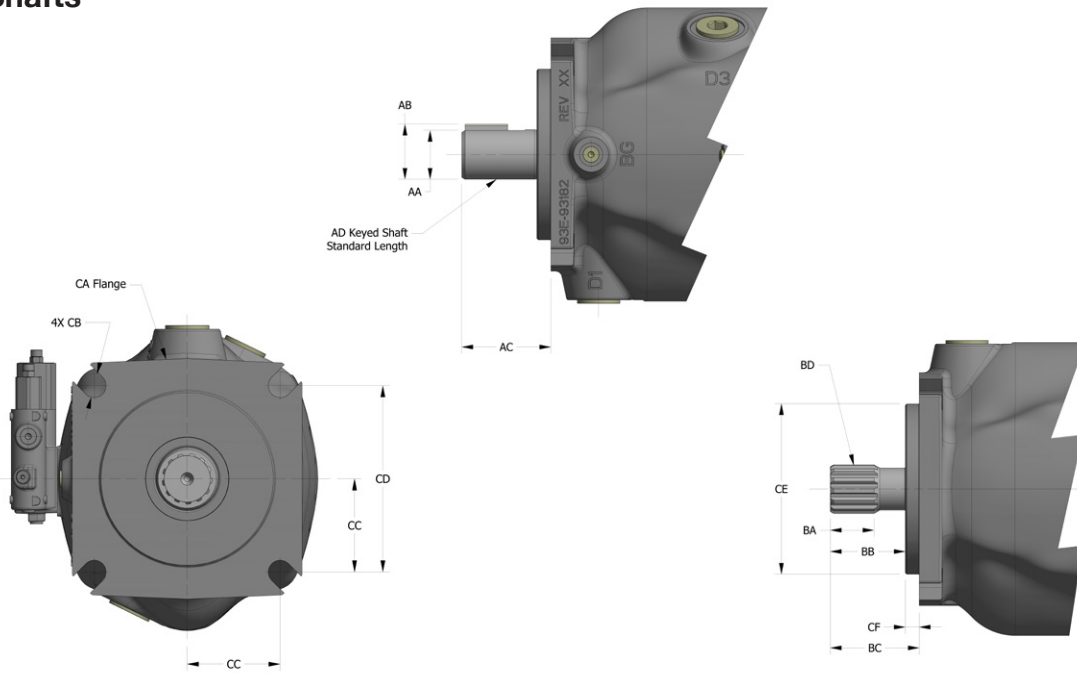

P1/PD-140 Mounting Flange & Shaft Dimensions		
Dimension	ISO (Code 04)	SAE (Code 01 or 02)
ØAA	50.03/50.00	44.45/44.43
AB	53.40/53.21	49.35/49.18
AC	92.0	75.0
AD	ISO 3019-2: E50N	SAE J744 44-1 (D)
BA	N/A	39.0
BB	N/A	67.0
BC	N/A	75.0
BD	N/A	SPLINE: SAE J498-B 1969 SAE 44-4(D) INVOLUTE SPLINE CLASS 1 FLAT ROOT SIDE FIT NUMBER OF TEETH - 13 PITCH - 8/16 PRESSURE ANGLE - 30° MAJOR DIAMETER - 43.71/43.59 PITCH DIAMETER - 41.275
CA	ISO 3019-2: 180B4SW	SAE J744: JUN 96 152-4 (D)
CB	18.2/17.8	20.9/20.5
CC	79.2	80.8
CD	158.4	161.6
CE	180.00/179.95	152.40/152.35
CF	9.5/9.0	12.7/12.2
Keyway Width	14.00/13.95	11.14/11.09

**Pump Installation - P1/PD-140
End Ports
“L” or “AM” Control Option**

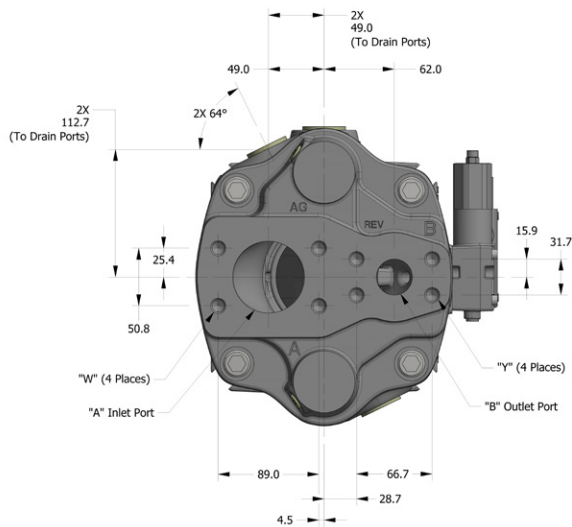
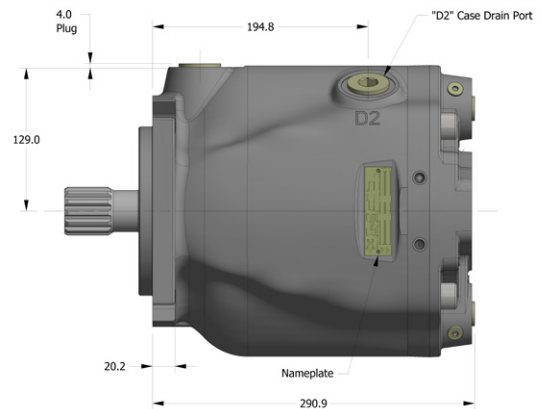
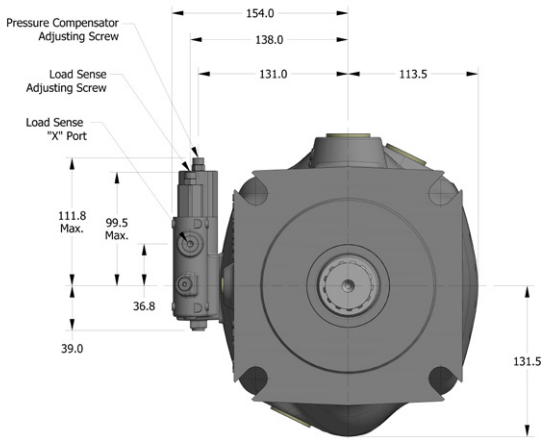
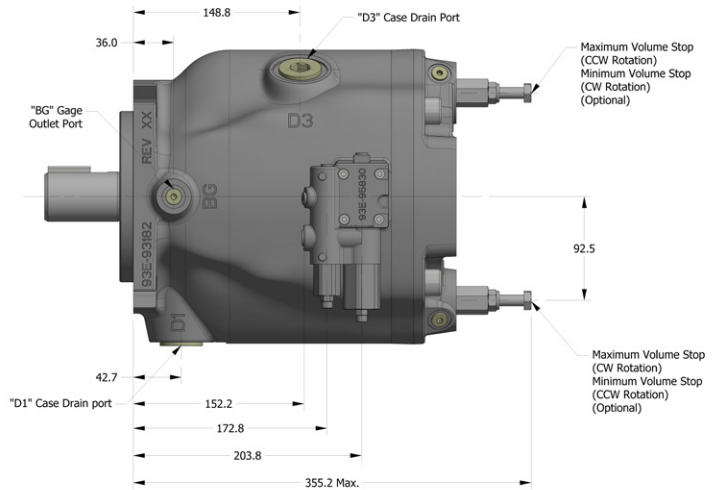

P1/PD-140 Port Sizes			
Ports	SAE Flanged	Metric Flanged	BSPP
"A" Inlet	2-1/2" Code 61	DN63	-
W Threads	1/2-13 UNC-2B	M12x1.75-6H	-
"B" Outlet	1-1/4" Code 62	DN32	-
Y Threads	1/2-13 UNC-28	M12x1.75-6H	-
BG, X	SAE-4	M12x1.5	1/4"
D1, D2, D3	SAE-16	M33x2	1"

Note A: SAE flanged ports conform to SAE J518
 Note B: SAE o-ring port conforms to SAE 1926
 Note C: Metric flanged ports conform to ISO 6162
 Note D: Metric o-ring boss port conforms to ISO 6149-1
 Note E: BSPP port conforms to ISO 228-1

**Pump Installation - P1/PD-140
Side Ports
“L” or “AM” Control Option**

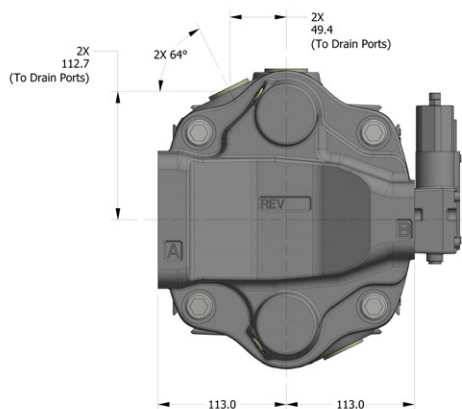
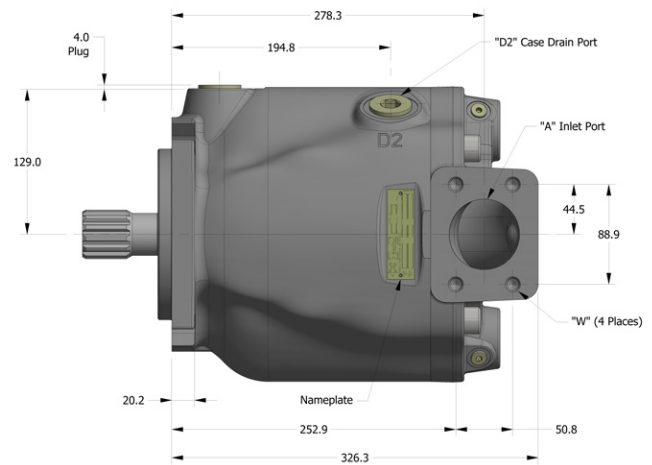
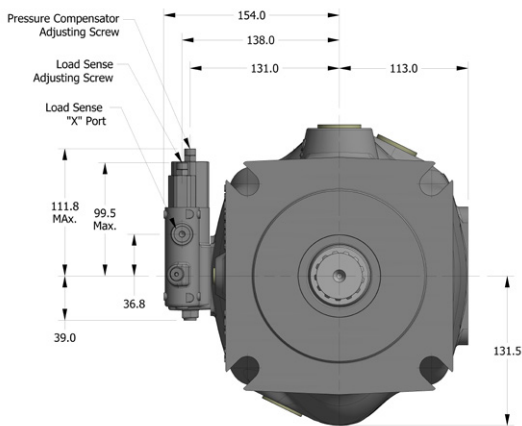
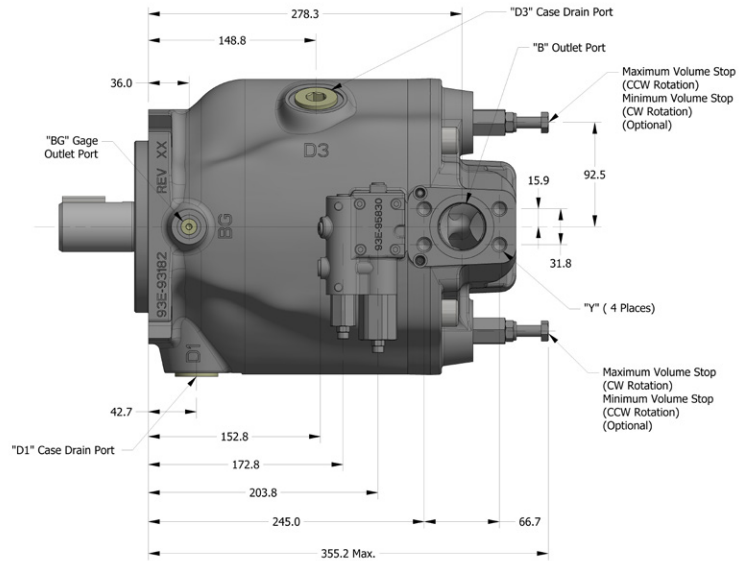

P1/PD-140 Port Sizes			
Ports	SAE Flanged	Metric Flanged	BSPP
"A" Inlet	2-1/2" Code 61	DN63	-
W Threads	1/2-13 UNC-2B	M12x1.75-6H	-
"B" Outlet	1-1/4" Code 62	DN32	-
Y Threads	1/2-13 UNC-28	M12x1.75-6H	-
BG, X	SAE-4	M12x1.5	1/4"
D1, D2, D3	SAE-16	M33x2	1"

Note A: SAE flanged ports conform to SAE J518
 Note B: SAE o-ring port conforms to SAE 1926
 Note C: Metric flanged ports conform to ISO 6162
 Note D: Metric o-ring boss port conforms to ISO 6149-1
 Note E: BSPP port conforms to ISO 228-1

**Pump Installation - P1/PD-140
Side Ports with Thru-Drive
“L” or “AM” Control Option**

P1/PD-140 Port Sizes			
Ports	SAE Flanged	Metric Flanged	BSPP
"A" Inlet	2-1/2" Code 61	DN63	-
W Threads	1/2-13 UNC-2B	M12x1.75-6H	-
"B" Outlet	1-1/4" Code 62	DN32	-
Y Threads	1/2-13 UNC-28	M12x1.75-6H	-
BG, X	SAE-4	M12x1.5	1/4"
D1, D2, D3	SAE-16	M33x2	1"

Note A: SAE flanged ports conform to SAE J518
 Note B: SAE o-ring port conforms to SAE 1926
 Note C: Metric flanged ports conform to ISO 6162
 Note D: Metric o-ring boss port conforms to ISO 6149-1
 Note E: BSPP port conforms to ISO 228-1

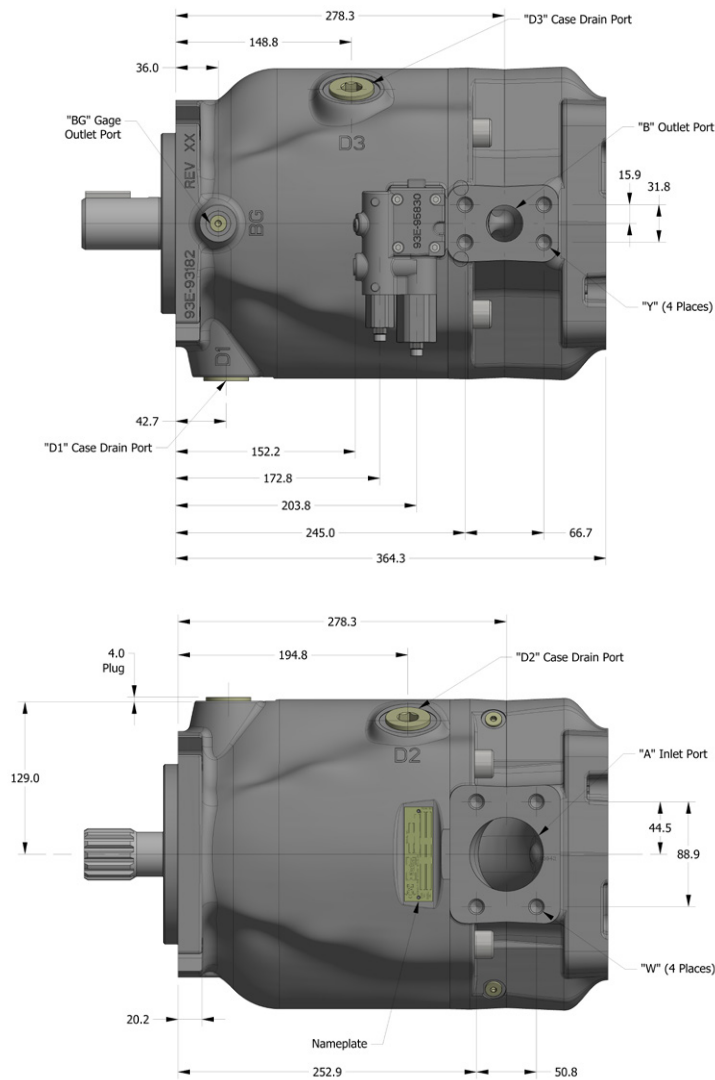

**Pump Installation - P1/PD-140
Side Ports with Thru-Drive
Mounting Options**

SAE-A Mounting Options Information	
Model Number T0*A Spline: ANSI B92.1 1996 SAE 16-4 (A) Involute Spline Class 5 Flat Root Side Fit Number of Teeth - 9 Pitch - 16/32 Pressure Angle - 30° Major Diameter - 13.06/12.93 mm Pitch Diameter - 14.29 mm	Model Number T0*H Spline: ANSI B92.1 1996 SAE 19-4 Involute Spline Class 5 Flat Root Side Fit Number of Teeth - 11 Pitch - 16/32 Pressure Angle - 30° Minor Diameter - 16.14/16.02 mm Pitch Diameter - 17.46 mm

SAE-B Mounting Options Information	
Model Number T0*B Spline: ANSI B92.1 1996 SAE 22-4 (B) Involute Spline Class 5 Flat Root Side Fit Number of Teeth - 13 Pitch - 16/32 Pressure Angle - 30° Minor Diameter - 19.28/19.15 mm Pitch Diameter - 20.64 mm	Model Number T0*Q Spline: ANSI B92.1 1996 SAE 25-4 (B-B) Involute Spline Class 5 Flat Root Side Fit Number of Teeth - 15 Pitch - 16/32 Pressure Angle - 30°h Minor Diameter - 22.40/22.28 mm Pitch Diameter - 23.81 mm

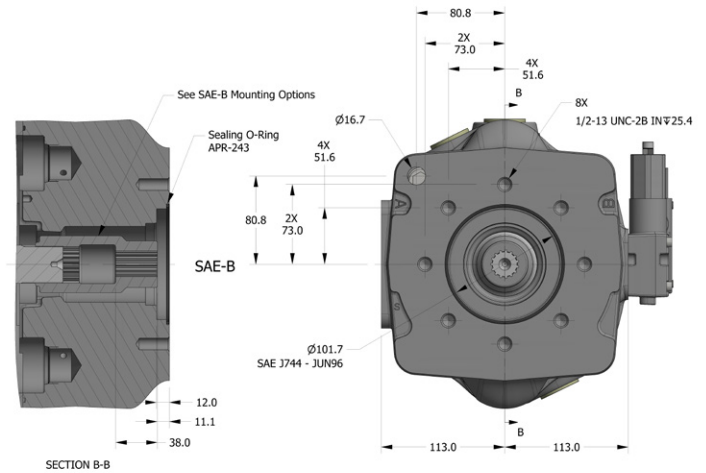
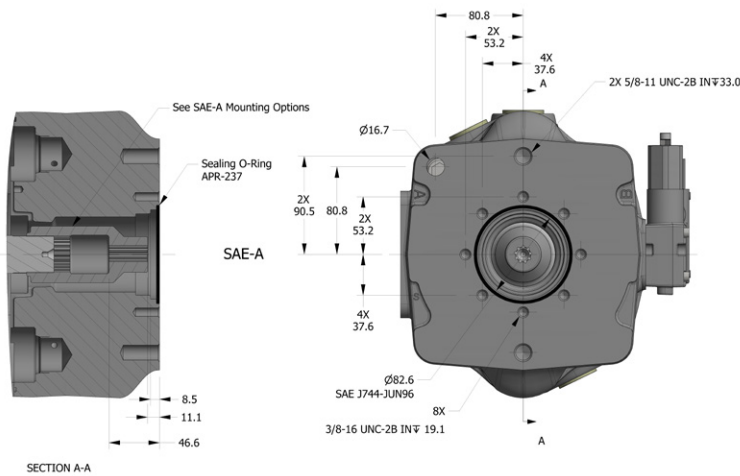

SAE-C Mounting Options Information	
Model Number T0*C Spline: ANSI B92.1 1996 SAE 32-4 (C) Involute Spline Class 5 Flat Root Side Fit Number of Teeth - 14 Pitch - 12/24 Pressure Angle - 30° Minor Diameter - 27.74/27.61 mm Pitch Diameter - 29.63 mm	Model Number T0*N Spline: ANSI B92.1 1996 SAE 38-4 (C-C) Involute Spline Class 5 Flat Root Side Fit Number of Teeth - 17 Pitch - 12/24 Pressure Angle - 30° Minor Diameter - 34.01/33.88 mm Pitch Diameter - 35.98 mm

SAE-D Mounting Options Information	
Model Number T0*D Spline: ANSI B92.1 1996 SAE 44-4 (D) Involute Spline Class 1 Flat Root Side Fit Number of Teeth - 13 Pitch - 8/16 Pressure Angle - 30° Minor Diameter - 38.38/38.25 mm Pitch Diameter - 41.28 mm	

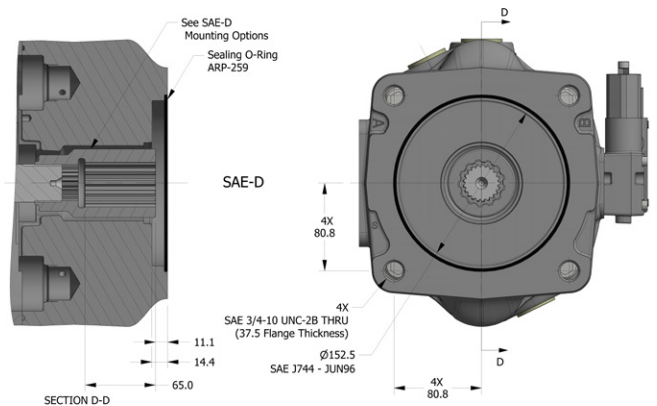
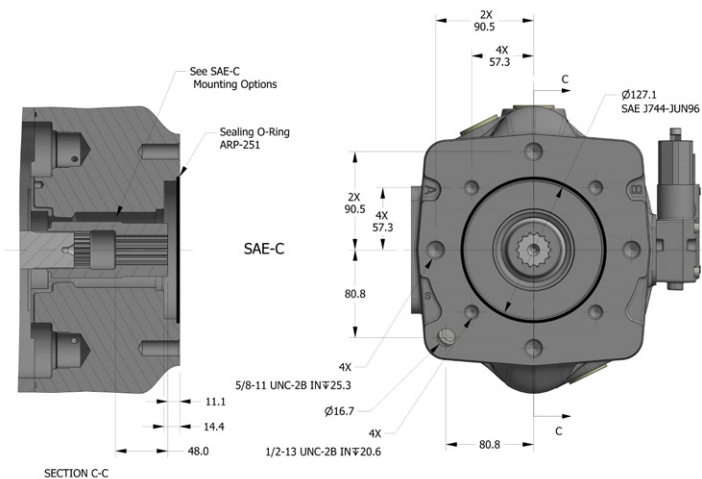

C0 Control

For C0 control dimensions see frame size dimensional section because the C0 control uses the same control housing as L & AM controls.

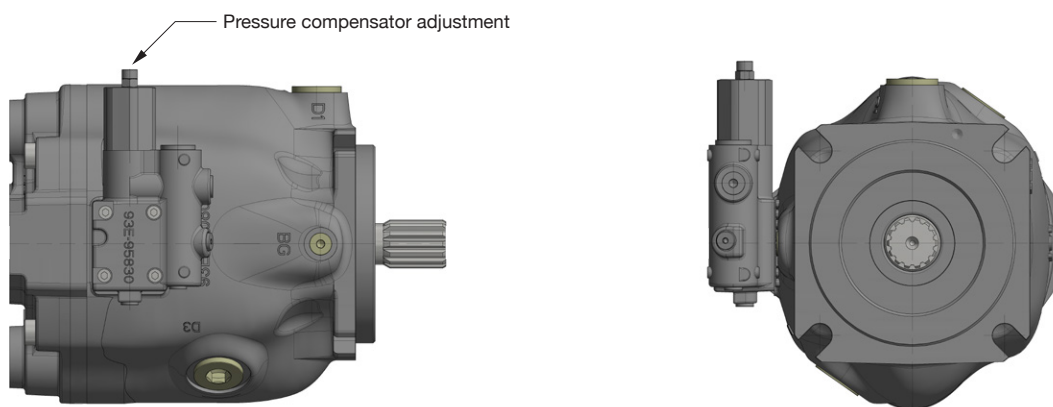

P*075 shown

L0T & AMT Control

L0T & AMT (45 & 60cc)

The L0T & AMT controls on the 45 & 60cc use the same adapter block that is used on the AN & ANT controls.

L0T & AMT (75-140cc)

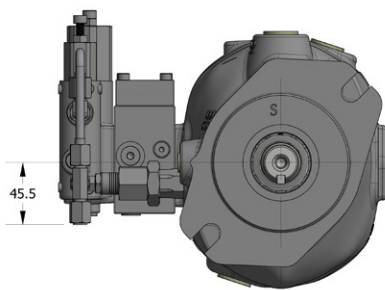
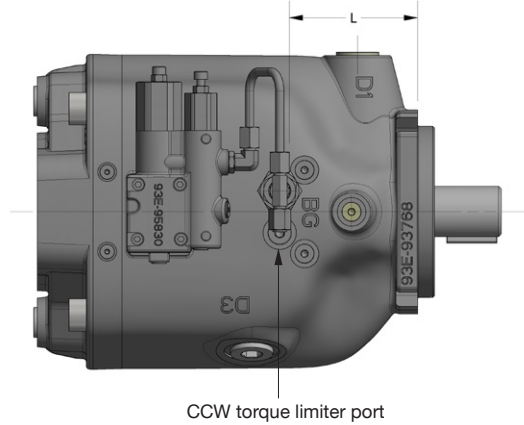
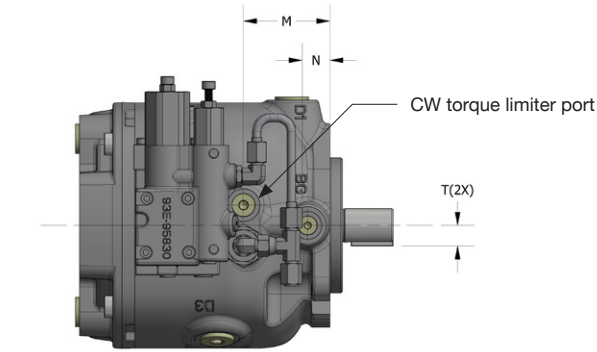

P*045 CCW shown

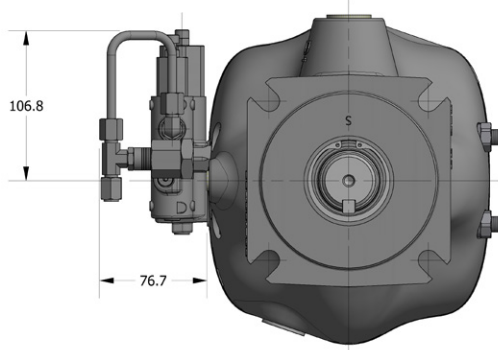

P*100 CW shown

L0T & AMT Control Dimensions (mm)				
Model	L	M	N	T
P*045	**	65	21	15
P*060	**	70	25	20
P*075/085	64	72	**	15
P*100	95	103	**	16
P*140	117	128	**	16

AN & ANT Control

The AN & ANT controls use the AM compensator with the addition of an adapter block and tubing.

AN Control (All sizes)

ANT Control (45-140cc only)

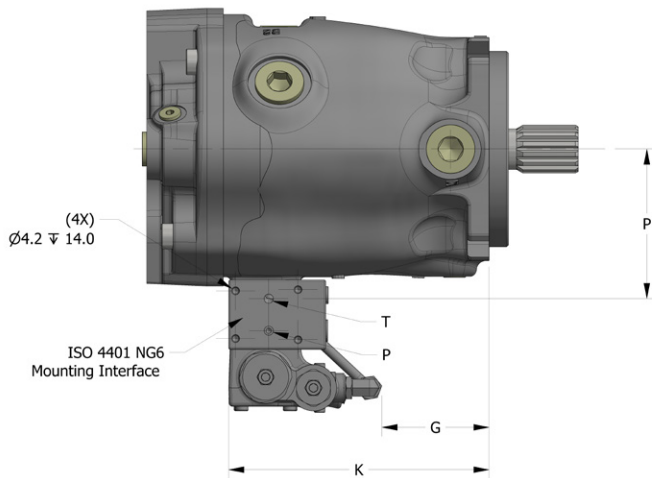
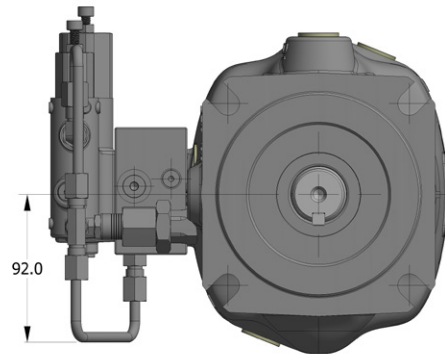
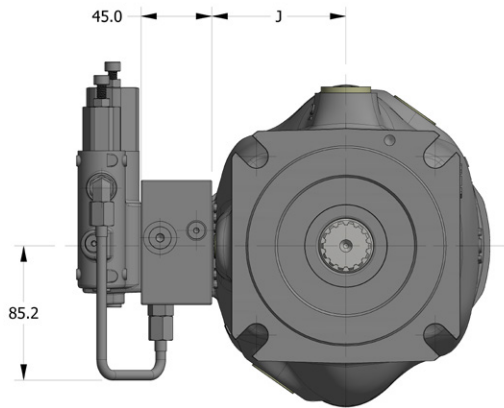
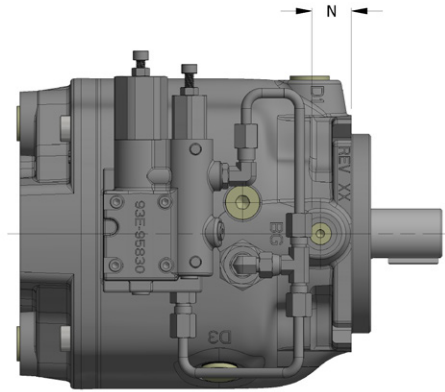
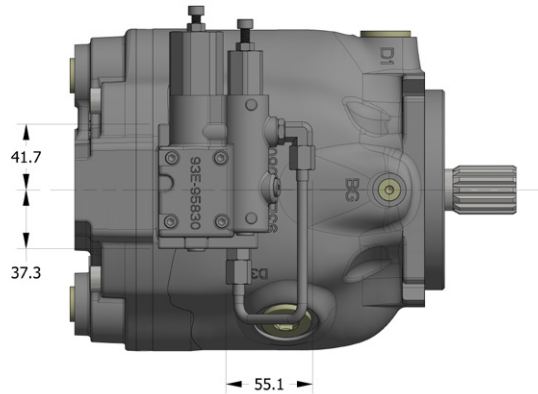

P*060 shown

AN & ANT Control Dimensions (mm)					
Model	G	J	K	N	P
P*018	18	65	117	**	77
P*028	37	71	135	**	83
P*045	47	78	146	21	90
P*060	60	82	159	25	94
P*075/085	70	85	169	28	97
P*100	117	101	216	58	113
P*140	129	113	228	51	125

P*075 shown

AE/AF Control

The AE/AF control uses the AM compensator with same adapter block that used on the AN & ANT controls

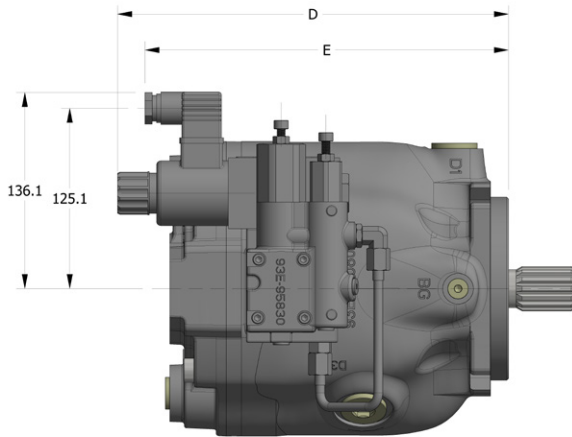

C0*, L0* Unload Control

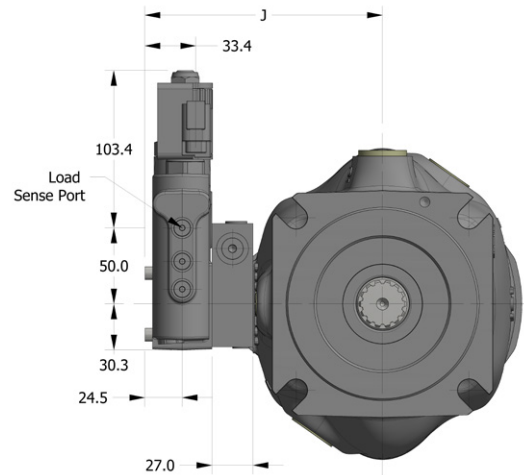
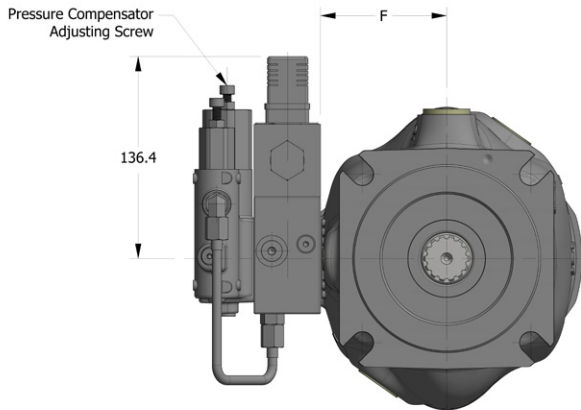
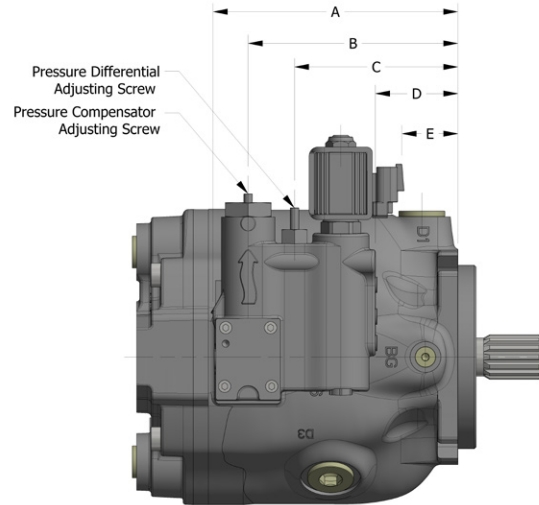

P*075 shown

AE/AF Control Dimensions by Frame Size (mm)			
Model	D	E	F
P*018	207	188	65
P*028	225	206	71
P*045	236	217	78
P*060	248	229	82
P*075/085	271	252	85
P*100	305	286	101
P*140	317	298	113

Unload (*03 & *06) Control Dimensions by Frame Size (mm)						
Model	A	B	C	D	E	J
P*028	134	109	77	25	12	142
P*045	145	120	88	35	15	149
P*060	157	132	100	48	27	153
P*075/085	167	142	110	71	50	156
P*100	214	189	157	105	86	172
P*140	226	201	169	117	94	184

AG/AH Control

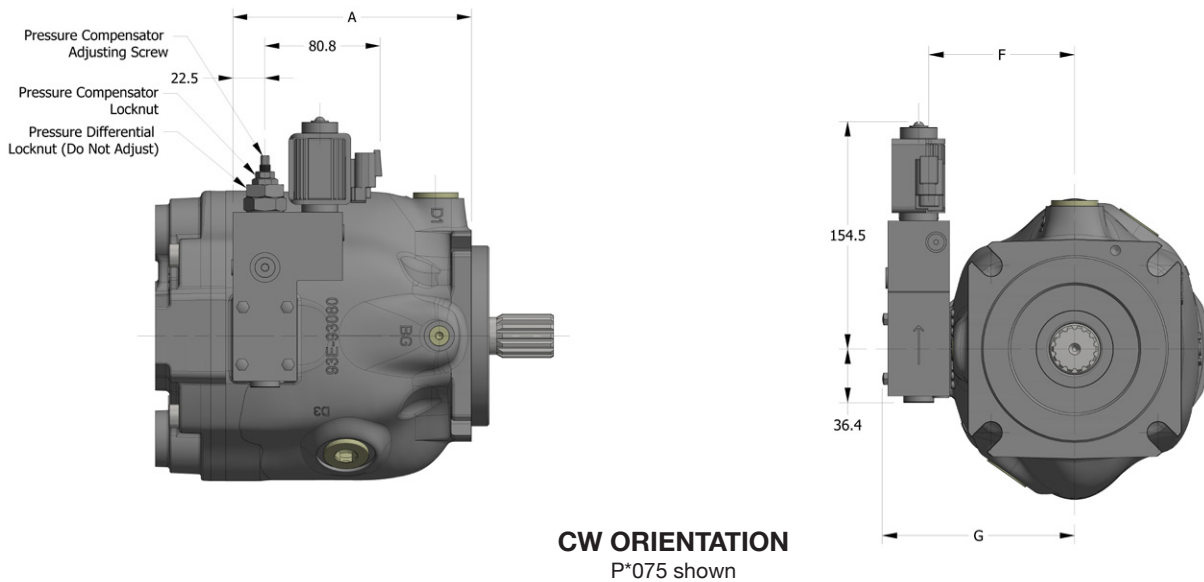
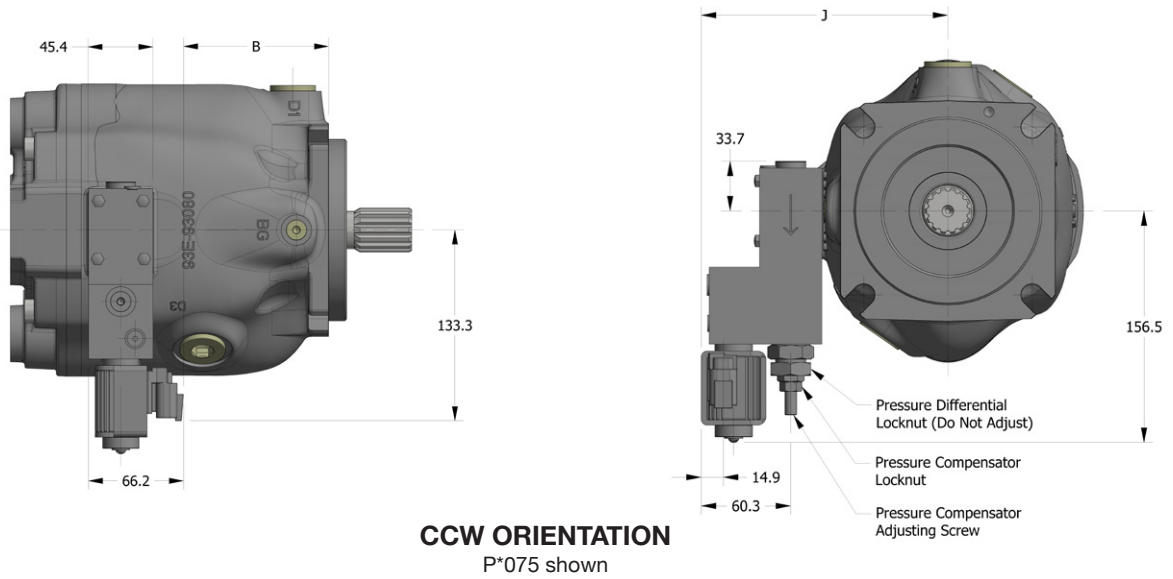

AG/AH Control Dimensions by Frame Size (mm)					
Model	A	B	F	G	J
P*018	116	71	79	111	142
P*028	134	89	85	116	148
P*045	145	100	92	124	155
P*060	157	112	96	128	160
P*075/085	168	123	99	131	162
P*100	214	169	115	147	179
P*140	226	181	127	159	190

P, T, S, U Electronic Control Options

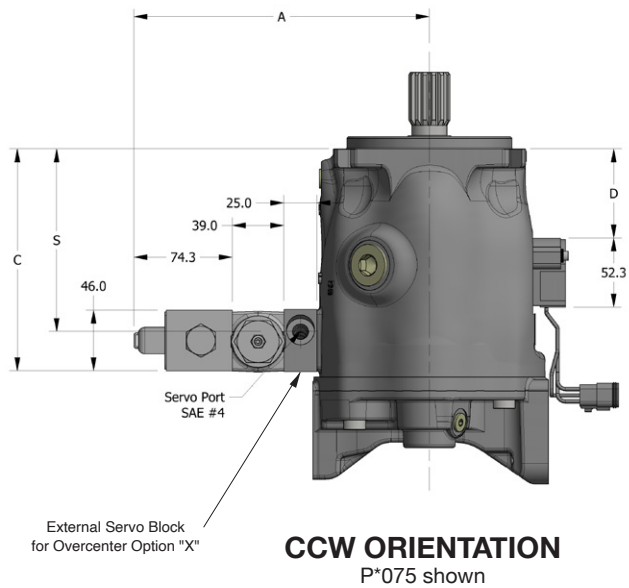
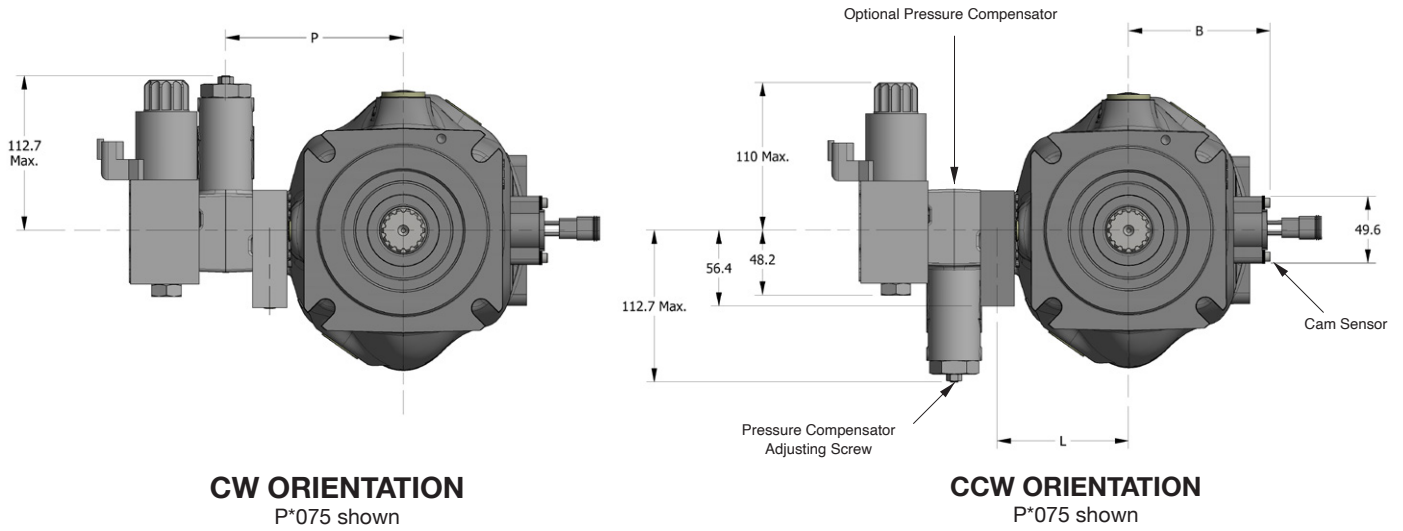

RDEC Control Dimensions by Frame Size (mm)							
Model	A	B	C	D	L	P	S
P*018	203	85	116	49	**	85	**
P*028	209	89	135	56	**	91	**
P*045	216	96	145	60	91	123	116
P*060	220	105	158	64	95	127	133
P*075/085	223	108	168	68	98	130	138
P*100	239	121	215	101	114	146	185
P*140	251	130	227	96	126	158	196