

- **Three-piece cast iron construction**  
High efficiency and long life in severe operating environments.
- **Low friction bushing**  
Provides strength in heavy duty applications.
- **Balanced thrust plates**  
Optimize pump efficiency.
- **Largest journal bearings available**  
for high pressure and long life.



Product Features	Description
<b>Pump Type</b>	Heavy-duty, cast iron, external gear
<b>Mounting</b>	SAE standard flanges, ZF, others
<b>Ports</b>	SAE split flanges and other types of threaded ports, see Specifications
<b>Shaft Style</b>	SAE splined, keyed, and others, see Specifications
<b>Maximum Speed</b>	400 - 3000 rpm, see Specifications
<b>Theor. displacement</b>	See Specifications
<b>Drive</b>	Clockwise, counterclockwise, double. Direct drive with flexible coupling is recommended. Pumps subject to radial loads must be specified with an outboard bearing. Axial loading is not allowed.
<b>Inlet pressure</b>	30 psia (15psig) maximum pressure / 5 in. Hg maximum vacuum at operating temperature
<b>Outlet pressure</b>	See Specifications
<b>Hydraulic fluids</b>	Mineral oil, fire resistant fluids: water-oil emulsions 60/40, MFB; water-glycol, HFC; phosphate-esters, HFD (FPM seals required)

Product Features	Description
<b>Fluid viscosity</b>	From 7.5 to 1600 cSt (50 to 7500 sus). Recommended 15 to 75 cSt.
<b>Fluid temperature</b>	Mineral oil with standard seals: 0°F to 180°F (-20°C to 80°C); Fire resistant fluids HFB, HFC: 0°F to 150°F (-20°C to 65°C)
<b>Filtration</b>	ISO 4406 code: <ul style="list-style-type: none"> <li>• 19/16 at 2000 psi/140 bar</li> <li>• 17/14 at 3000 psi/210 bar</li> <li>• 15/12 at 4000 psi/275 bar</li> </ul>
<b>Direction of rotation (looking at the drive shaft)</b>	CW, CCW, Bi-Rotational
<b>Multiple pump assemblies</b>	Up to 6 gear selections of the same model, even with different gear widths
<b>Separate or common inlet capability</b>	Common

**⚠ WARNING:** This product can expose you to chemicals including lead or DEHP which are known to the state of California to cause cancer, birth defects, and other reproductive harm. [www.p65warnings.ca.gov](http://www.p65warnings.ca.gov)

**PGP/PGM330 Specifications**

PGP330 Frame Size	05	07	10	12	15	17	20
Displacement – cm <sup>3</sup> /rev (in <sup>3</sup> /rev)	16.1 (0.99)	24.2 (1.48)	32.3 (1.97)	40.4 (2.46)	48.4 (2.96)	56.5 (3.45)	64.6 (3.94)
Max continuous pressure – bar (psi)	241 (3,500)	241 (3,500)	241 (3,500)	241 (3,500)	241 (3,500)	224 (3,250)	207 (3,000)
Max Speed – RPM	3,000	3,000	3,000	3,000	3,000	3,000	3,000
Approximate Weight – Lbs. [kg]	33.6 [15.2]	34.8 [15.8]	36 [16.3]	37.3 [16.9]	38.5 [17.5]	40 [18.1]	41.3 [18.7]

PGM330 Frame Size	05	07	10	12	15	17	20
Displacement – cm <sup>3</sup> /rev (in <sup>3</sup> /rev)	16.1 (0.99)	24.2 (1.48)	32.3 (1.97)	40.4 (2.46)	48.4 (2.96)	56.5 (3.45)	64.6 (3.94)
Max continuous pressure – bar (psi)	241 (3,500)	241 (3,500)	241 (3,500)	241 (3,500)	241 (3,500)	224 (3,250)	207 (3,000)
Max Speed – RPM	3,000	3,000	3,000	3,000	3,000	3,000	3,000
Approximate Weight – Lbs. [kg]	33.6 [15.2]	34.8 [15.8]	36 [16.3]	37.3 [16.9]	38.5 [17.5]	40.0 [18.1]	41.3 [18.7]

**PGP/PGM330 Dimensions**

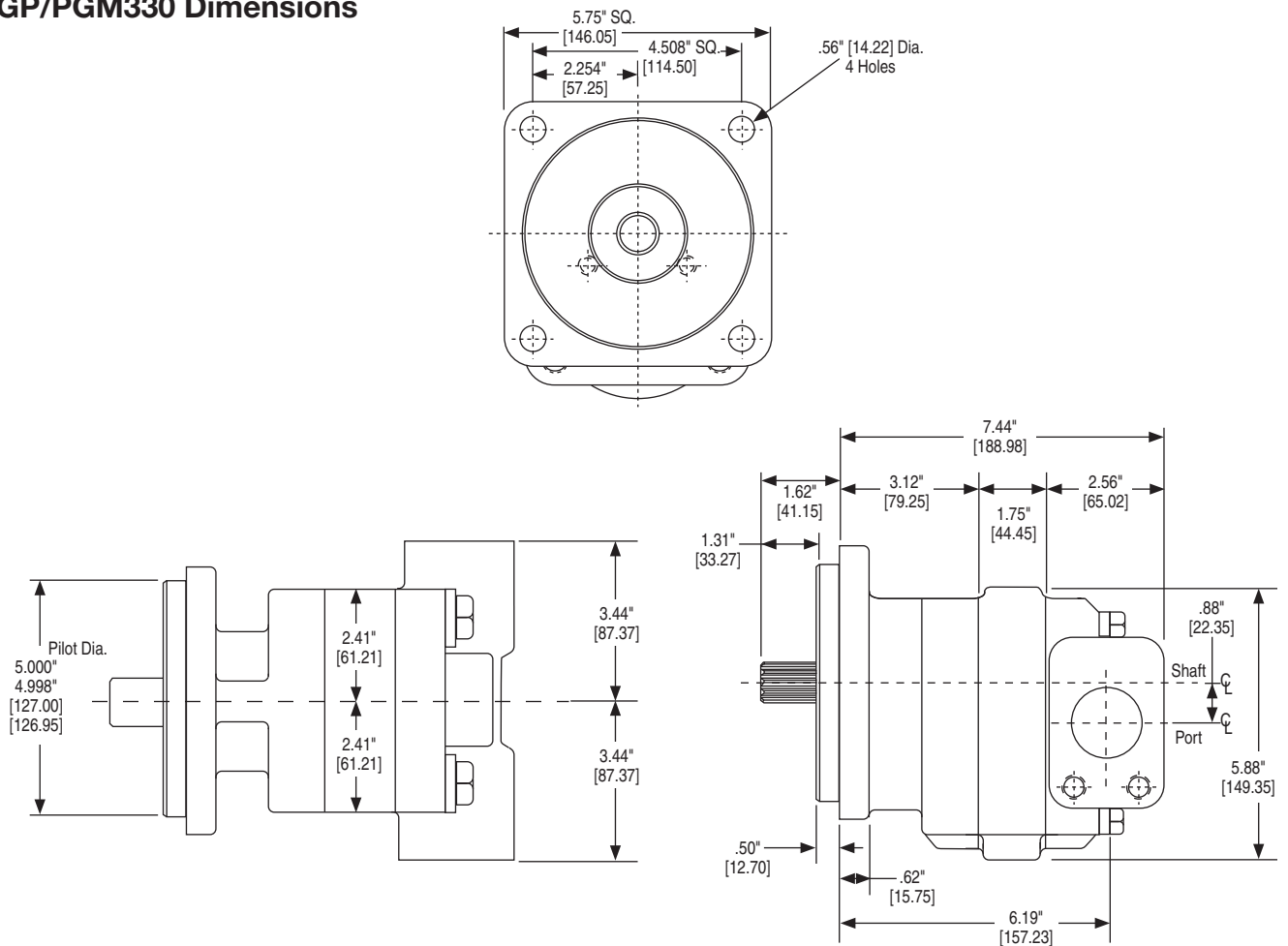

**WARNING:** This product can expose you to chemicals including lead or DEHP which are known to the state of California to cause cancer, birth defects, and other reproductive harm. [www.p65warnings.ca.gov](http://www.p65warnings.ca.gov)

**PGP/PGM330 Performance Data**

**PGP330 Pump Performance Data**

Speed RPM	Output Flow Input Power	Gear Widths						
		1/2"	3/4"	1"	1-1/4"	1-1/2"	1-3/4"	2"
900	GPM	3.2	5.1	7.0	8.8	10.6	12.4	14.3
	LPM	12	19	26	33	40	47	54
	HP	9	13	17	21	26	28	29
	kW	6	10	13	16	19	21	22
1200	GPM	4.5	7.0	9.5	12.0	14.5	16.9	19.4
	LPM	17	26	36	45	55	64	73
	HP	11	17	23	28	34	37	39
	kW	8	13	17	21	25	28	29
1500	GPM	5.8	8.9	12.1	15.2	18.3	21.4	24.5
	LPM	22	34	46	57	69	81	93
	HP	14	21	28	35	43	46	49
	kW	11	16	21	26	32	34	36
1800	GPM	7.1	10.8	14.7	18.4	22.1	25.9	29.6
	LPM	27	41	55	70	84	98	112
	HP	17	26	34	43	51	55	58
	kW	13	19	25	32	38	41	44
2100	GPM	8.4	12.7	17.2	21.6	26.0	30.3	34.7
	LPM	32	48	65	82	98	115	131
	HP	20	30	40	50	60	65	68
	kW	15	22	30	37	44	48	51
2400	GPM	9.6	14.7	19.8	24.8	29.8	34.8	39.8
	LPM	36	55	75	94	113	132	151
	HP	23	34	45	57	68	74	78
	kW	17	25	34	42	51	55	58
3000	GPM	12.2	18.5	24.9	31.2	37.5	43.8	50.1
	LPM	46	70	94	118	142	166	190
	HP	28	43	57	71	85	92	97
	kW	21	32	42	53	64	69	73

**PGM330 Motor Performance Data**

Speed RPM	Output Torque	Gear Widths									
		1" 3500 psi		1-1/4" 3500 psi		1-1/2" 3500 psi		1-3/4" 3250 psi		2" 3000 psi	
		A	B	A	B	A	B	A	B	A	B
900	in/lbs	10.1	1010	12.3	1270	14.5	1530	16.7	1665	19.0	1770
	Nm	38	114.1	47	143.5	55	172.9	63	188.1	72	200.0
1200	in/lbs	12.8	1005	15.7	1265	18.6	1525	21.4	1660	24.3	1760
	Nm	49	113.6	59	142.9	70	172.3	81	187.6	92	198.9
1500	in/lbs	15.6	1000	19.1	1255	22.6	1515	26.1	1650	29.6	1750
	Nm	59	113.0	72	141.8	85	171.2	99	186.4	112	197.7
1800	in/lbs	18.4	995	22.5	1250	26.6	1505	30.8	1640	34.9	1740
	Nm	69	112.4	85	141.2	101	170.0	116	185.3	132	196.6
2100	in/lbs	21.1	990	25.9	1240	30.7	1495	35.4	1625	40.2	1720
	Nm	80	111.9	98	140.1	116	168.9	134	183.6	152	194.3
2400	in/lbs	23.9	985	29.3	1235	34.7	1480	40.1	1605	45.5	1695
	Nm	90	111.3	111	139.5	131	167.2	152	181.3	172	191.5
3000	in/lbs	29.2	980	35.9	1230	42.6	1475	49.3	1595	56.0	1685
	Nm	110	110.7	136	139.0	161	166.7	186	180.2	212	190.4

A: Input Flow GPM/LPM; B: Output Torque IN/LBS/Nm

Note: In accordance with our policy of continuing product development, we reserve the right to change specifications shown in this catalog without notice.

**WARNING:** This product can expose you to chemicals including lead or DEHP which are known to the state of California to cause cancer, birth defects, and other reproductive harm. [www.p65warnings.ca.gov](http://www.p65warnings.ca.gov)

**Input**

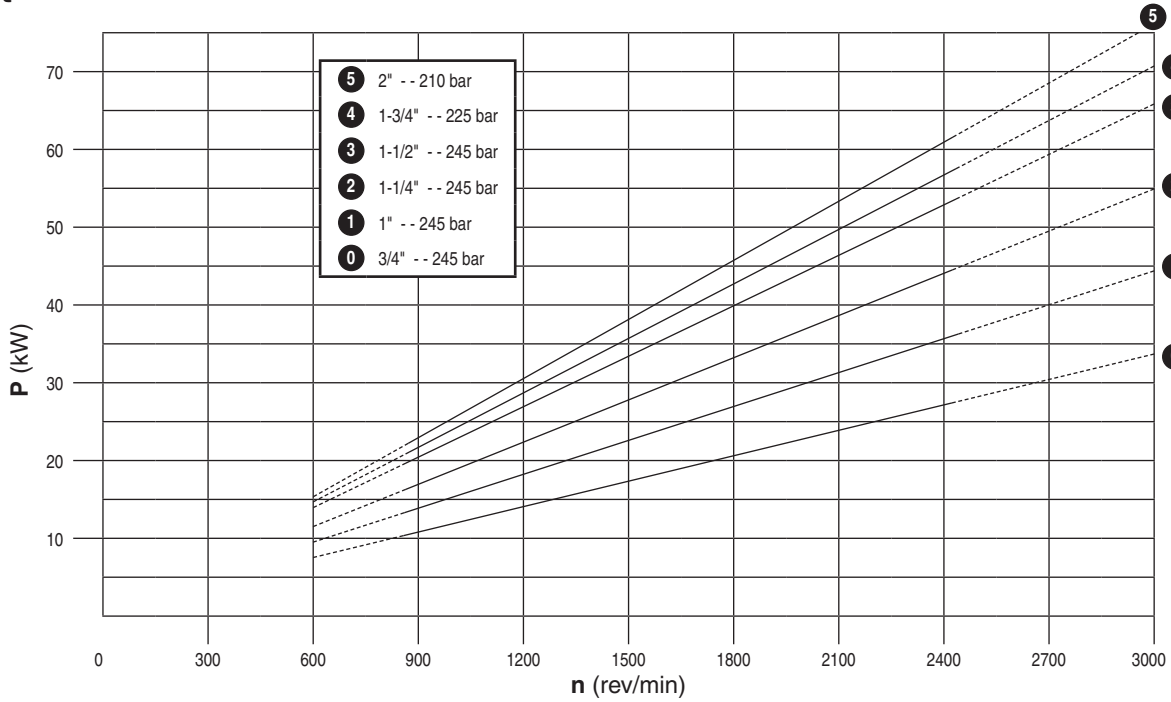

**Output**

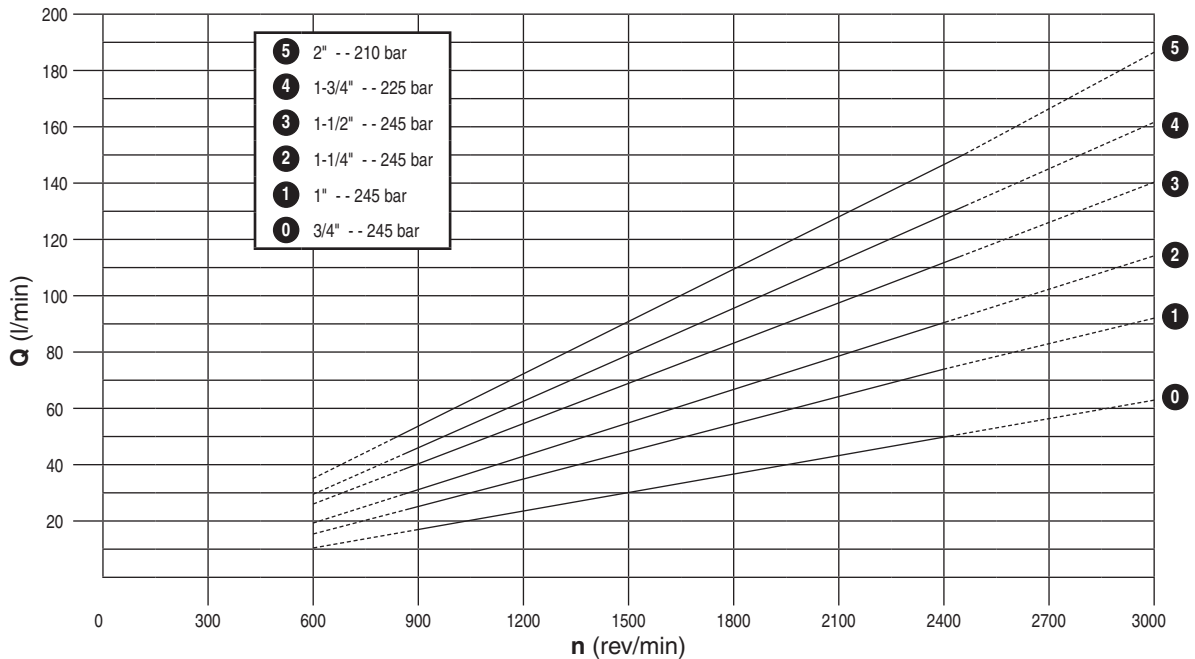

**WARNING:** This product can expose you to chemicals including lead or DEHP which are known to the state of California to cause cancer, birth defects, and other reproductive harm. [www.p65warnings.ca.gov](http://www.p65warnings.ca.gov)

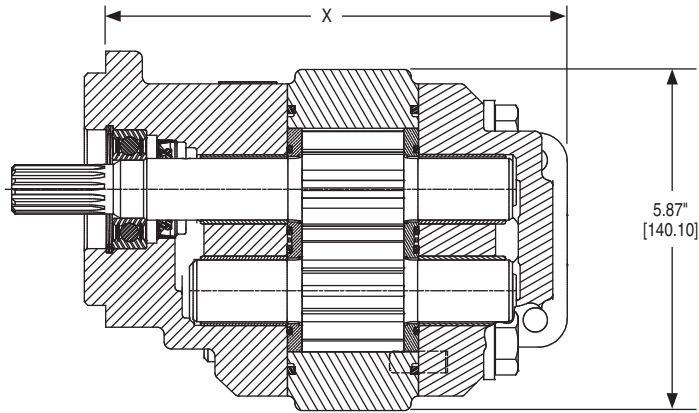

X DIMENSION							
SEC CODE	05	07	10	12	15	17	20
42	6.69" [169.93]	6.94" [176.28]	7.19" [182.63]	7.44" [188.98]	7.69" [195.33]	7.94" [201.68]	8.19" [208.02]
78	6.69" [169.93]	6.94" [176.28]	7.19" [182.63]	7.44" [188.98]	7.69" [195.33]	7.94" [201.68]	8.19" [208.02]
97	6.69" [169.93]	6.94" [176.28]	7.19" [182.63]	7.44" [188.98]	7.69" [195.33]	7.94" [201.68]	8.19" [208.02]

**WARNING:** This product can expose you to chemicals including lead or DEHP which are known to the state of California to cause cancer, birth defects, and other reproductive harm. [www.p65warnings.ca.gov](http://www.p65warnings.ca.gov)

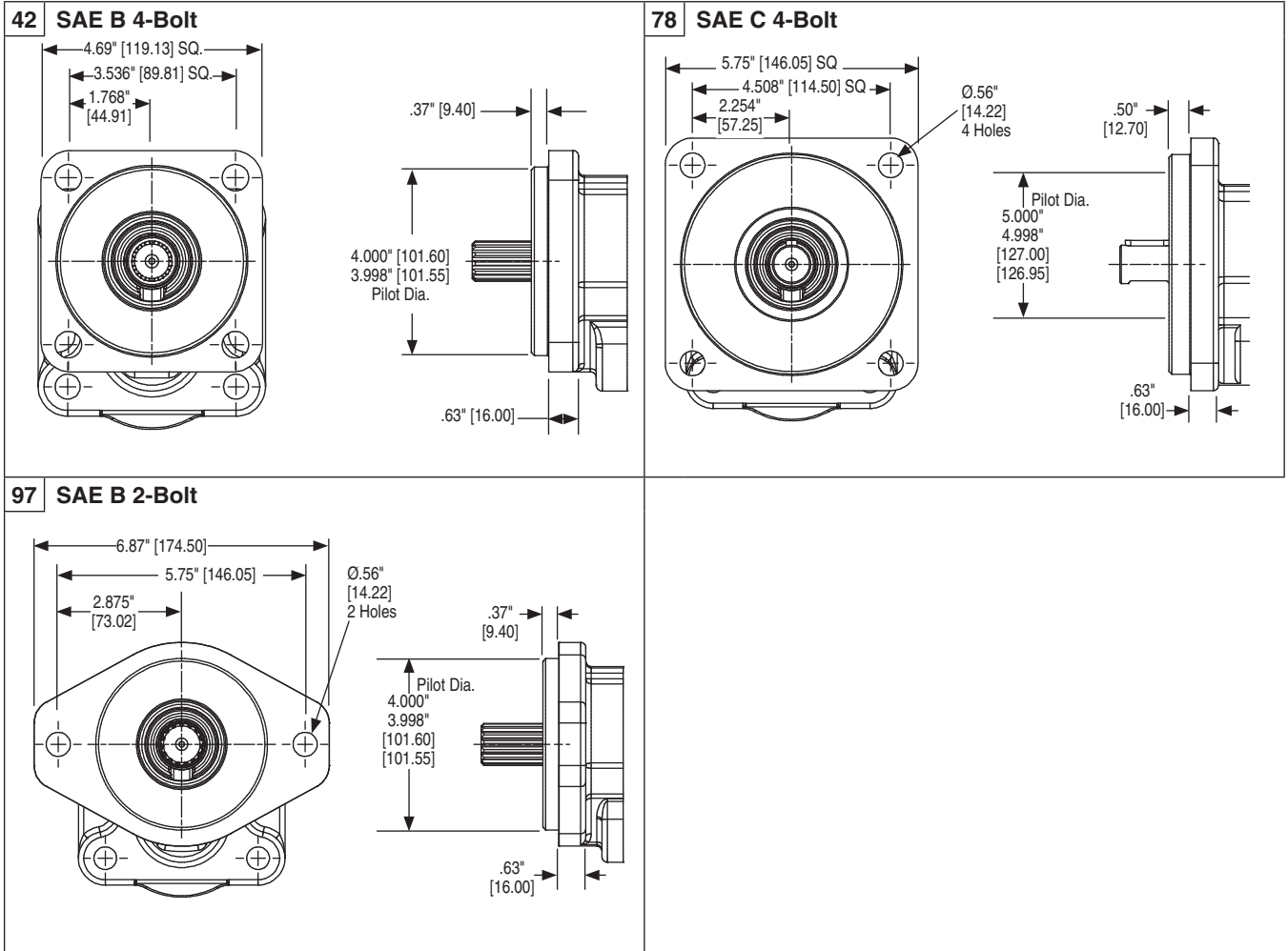

**WARNING:** This product can expose you to chemicals including lead or DEHP which are known to the state of California to cause cancer, birth defects, and other reproductive harm. [www.p65warnings.ca.gov](http://www.p65warnings.ca.gov)

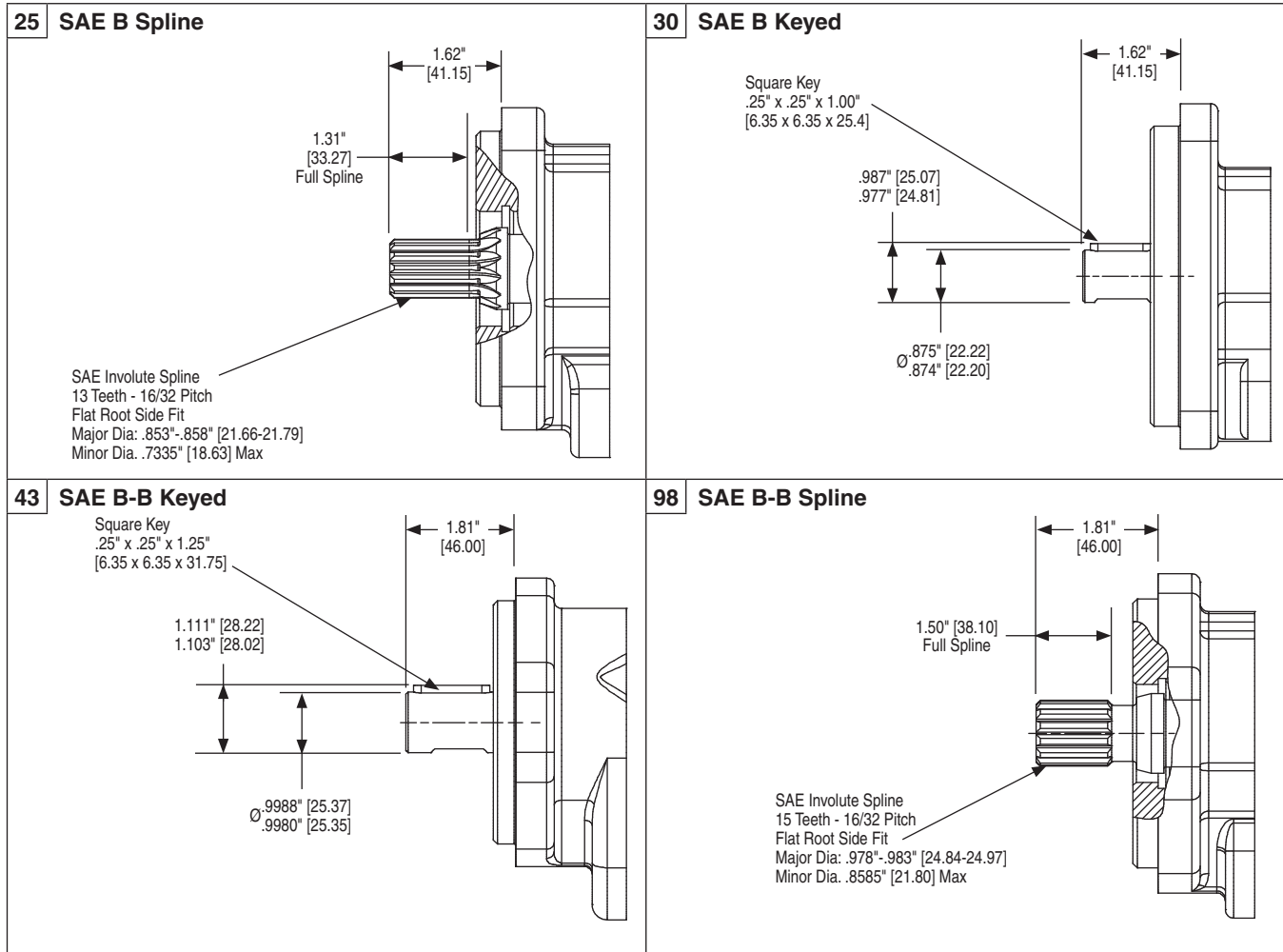

Shaft Style		Integral: 1 2 pieces: 2	Maximum Torque	
			lb-ft	Nm
SAE A	Splined - 9 Teeth	1	-	-
	5/8" Keyed	1 2	- -	- -
SAE B	Splined - 13 Teeth	1 2	242 159	328 215
	7/8" Keyed	1 2	167 159	226 215
SAE BB	Splined - 15 Teeth	1 2	371 159	503 215
	1" Keyed	1 2	250 159	339 215
SAE C	Splined - 14 Teeth	1 2 2	- 159 159	- 215 215
	1.25" Keyed	1 2	- 159	- 215
	Connecting Shaft		159	215

Torque (lb-ft) =  $\frac{\text{Pressure (PSI)} \times \text{Displacement (in}^3\text{/rev)}}{75.4}$

Torque (Nm) =  $\frac{\text{Pressure (Bar)} \times \text{Displacement (cc/rev)}}{62.8}$

**⚠ WARNING:** This product can expose you to chemicals including lead or DEHP which are known to the state of California to cause cancer, birth defects, and other reproductive harm. [www.p65warnings.ca.gov](http://www.p65warnings.ca.gov)

**SAE Flanged Ports UNC Thread (SSS)**

A		B		C		D	E	
inch	mm	inch	mm	inch	mm	UNC	inch	mm
0.50	12.7	0.69	17.5	1.50	38.1	5/16"-18	0.94	23.9
0.75	19.1	0.88	22.3	1.88	47.7	3/8"-16	0.88	22.4
1.00	25.4	1.03	26.2	2.06	52.2	3/8"-16	0.88	22.4
1.25	31.8	1.19	30.2	2.31	58.7	7/16"-14	1.12	28.4
1.50	38.1	1.41	35.7	2.75	69.9	1/2"-13	1.06	26.9
2.00	50.8	1.69	42.9	3.06	77.8	1/2"-13	1.06	26.9
2.50	63.5	2.00	50.8	3.50	88.9	1/2"-13	1.19	30.2

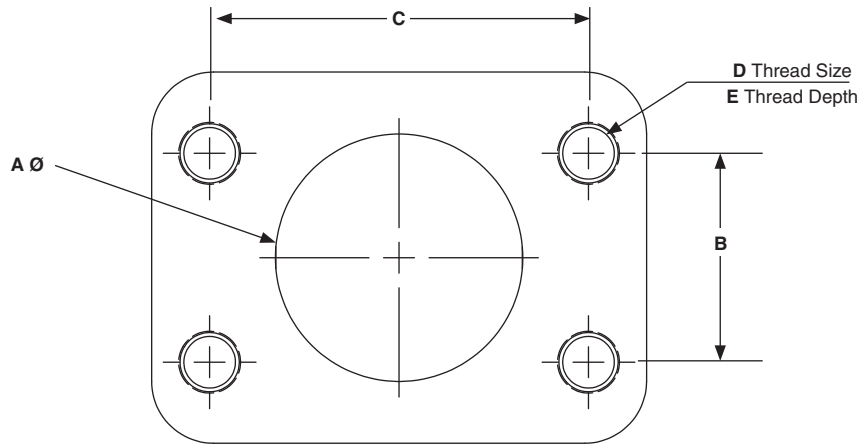

**SAE Straight Thread (ODT)**

ODT	A UNF	B		C		D		E	
		inch	mm	inch	mm	inch	mm	inch	mm
1/2"	3/4"-16	.56	14.3	1.19	30.2	.09	2.4	.10	2.55
5/8"	7/8"-14	.66	16.7	1.34	34.1	.09	2.4	.10	2.55
3/4"	1-1/16"-12	.75	19.1	1.62	41.3	.09	2.4	.13	3.30
1"	1-5/16"-12	.75	19.1	1.91	48.5	.09	2.4	.13	3.30
1-1/4"	1-5/8"-12	.75	19.1	2.27	57.7	.09	2.4	.13	3.35
1-1/2"	1-7/8"-12	.75	19.1	2.56	65.0	.09	2.4	.13	3.35
2"	2-1/2"-12	.75	19.1	3.48	88.4	.09	2.4	.13	3.35

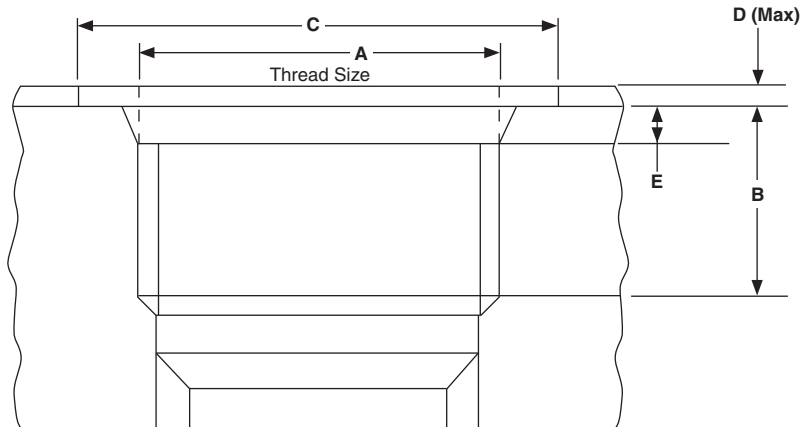

**WARNING:** This product can expose you to chemicals including lead or DEHP which are known to the state of California to cause cancer, birth defects, and other reproductive harm. [www.p65warnings.ca.gov](http://www.p65warnings.ca.gov)



Tandem: Repeat if Necessary

PG	1	330	2	3	3	4	4	5	5	6	6	7	7	8	8	9	9	6	6	7	7	10
----	---	-----	---	---	---	---	---	---	---	---	---	---	---	---	---	---	---	---	---	---	---	----

Code	1 – Type
P	Pump
M	Motor

Code	2 – Unit
A	Single Unit
B	Tandem Unit (flush studs)
C	Single or Tandem with two-piece shaft (O.B. bearing required)
L	Unit with Extended Studs

Code	3 – Shaft End Cover
1	Pump, cw w/o O.B. bearing
2	Pump, ccw w/o O.B. bearing
4	Pump, cw with O.B. bearing
5	Pump, ccw with O.B. bearing
8	Motor, bi-rot with O.B. bearing + 1/4" ODT drain
9	Motor, bi-rot w/o O.B. bearing + 1/4" ODT drain

Code	4 – Shaft End Cover
42	SAE B 4-Bolt
78	SAE C 4-Bolt
97	SAE B 2-Bolt

Code	5 – Port End Cover			
<b>SIDE PORTED</b>				
	CW	CCW	IN	OUT
<b>SAE Split Flange (pump)</b>				
EJ	JE	1-1/2"	1-1/4"	
EK	KE	1-1/2"	1"	
EL	LE	1-1/4"	1-1/4"	
EM	ME	1-1/4"	1"	
EN	NE	1"	1"	
OF	FO	1-1/2"	-	
OG	GO	1-1/4"	-	
OJ	JO	1"	-	
OM	MO	-	1-1/4"	
ON	NO	-	1"	
<b>SAE Split Flange (motor)</b>				
CS-Double		1-1/4"	1-1/4"	
CT-Double		1"	1"	
CV-Double		3/4"	3/4"	
<b>OD Tube Porting (pump)</b>				
FJ	JF	1-1/4"	1"	
FL	LF	1"	1"	
BG	GB	1-1/4"	-	
BJ	JB	1"	-	
BN	NB	-	1"	
<b>OD Tube Porting (motor)</b>				
VC-Double		1-1/4"	1-1/4"	
VN-Double		1"	1"	
VR-Double		3/4"	3/4"	
<b>Unported (pump)</b>				
BI		Unported		
<b>Unported (motor)</b>				
BA		Unported		

Code	6 – Gear Housing
AB	Pump
EB	Motor

Code	7 – Gear Width				
	Gear Width	in. <sup>3</sup> /rev.	cm <sup>3</sup> /rev.	Max Pressure	
				psi	bar
05	1/2"	0.99	16.1	3500	241
07	3/4"	1.48	24.2	3500	241
10	1"	1.97	32.3	3500	241
12	1-1/4"	2.46	40.4	3500	241
15	1-1/2"	2.96	48.4	3500	241
17	1-3/4"	3.45	56.5	3250	224
20	2"	3.94	64.6	3000	207

Code	8 – Shaft Type
7	SAE C Spline (two-piece only)
11	SAE C Keyed (two-piece only)
25	SAE B Spline
30	SAE B Keyed
43	SAE BB Keyed

 **WARNING:** This product can expose you to chemicals including lead or DEHP which are known to the state of California to cause cancer, birth defects, and other reproductive harm. [www.p65warnings.ca.gov](http://www.p65warnings.ca.gov)

Tandem: Repeat if Necessary

PG	1	330	2	3	3	4	4	5	5	6	6	7	7	8	8	9	9	6	6	7	7	10
----	---	-----	---	---	---	---	---	---	---	---	---	---	---	---	---	---	---	---	---	---	---	----

<b>98</b>	SAE BB Splined				
For Single or Tandem Units - unless noted					
<b>Code</b>	<b>9 – Bearing Carriers</b>				
<b>DUAL OUTLET - PUMP ONLY</b>					
Outlets: for clockwise porting the top port number comes first; for counter-clockwise porting the bottom port number comes first					
<b>CW</b>	<b>CCW</b>	<b>IN</b>	<b>OUT</b>		
<b>SAE Split Flange</b>					
<b>AM</b>	<b>MA</b>	2"	1-1/4"	1-1/4"	
<b>AN</b>	<b>NA</b>	2"	1-1/4"	1"	
<b>AP</b>	<b>PA</b>	2"	1"	1"	
<b>AT</b>	<b>TA</b>	1-1/2"	1-1/4"	1-1/4"	
<b>AU</b>	<b>UA</b>	1-1/2"	1-1/4"	1"	
<b>AV</b>	<b>VA</b>	1-1/2"	1"	1"	
<b>AW</b>	<b>WA</b>	1-1/4"	1-1/4"	1-1/4"	
<b>AX</b>	<b>XA</b>	1-1/4"	1-1/4"	1"	
<b>AY</b>	<b>YA</b>	*1-1/4"	1"	1"	
<b>AZ</b>	<b>ZA</b>	1"	1"	1"	
<b>OD Tube Porting</b>					
<b>GV</b>	<b>VG</b>	1-1/2"	1"	1"	
<b>GY</b>	<b>YG</b>	1-1/4"	1"	1"	
<b>GZ</b>	<b>ZG</b>	1"	1"	1"	

\* Outlet port for rear section

<b>Code</b>	<b>9 – Bearing Carriers (cont.)</b>			
<b>SINGLE OUTLET - PUMP ONLY</b>				
Outlet for front section				
<b>CW</b>	<b>CCW</b>	<b>IN</b>	<b>OUT</b>	
<b>SAE Split Flange</b>				
<b>HB</b>	<b>BH</b>	2"	1-1/2"	
<b>HC</b>	<b>CH</b>	2"	1-1/4"	
<b>HF</b>	<b>FH</b>	2"	1"	
<b>HL</b>	<b>LH</b>	1-1/2"	1-1/2"	
<b>HM</b>	<b>MH</b>	1-1/2"	1-1/4"	
<b>HN</b>	<b>NH</b>	1-1/2"	1"	
<b>HO</b>	<b>OH</b>	1-1/4"	1-1/4"	
<b>HP</b>	<b>PH</b>	1-1/4"	1"	
<b>HQ</b>	<b>QH</b>	1"	1"	
<b>RS</b>	<b>SR</b>	1-1/4"	1"	
<b>OD Tube Porting</b>				
<b>KM</b>	<b>MK</b>	1-1/2"	1-1/4"	
<b>KN</b>	<b>NK</b>	1-1/2"	1"	
<b>KO</b>	<b>OK</b>	1-1/4"	1-1/4"	
<b>KP</b>	<b>PK</b>	1-1/4"	1"	
<b>KQ</b>	<b>QK</b>	1"	1"	

<b>Code</b>	<b>9 – Bearing Carriers (cont.)</b>			
<b>COMBINED OUTLET</b>				
Outlet for front section				
<b>CW</b>	<b>CCW</b>	<b>IN</b>	<b>OUT</b>	
<b>SAE Split Flange (pump)</b>				
<b>UN</b>	<b>NU</b>	2"	1-1/2"	
<b>UO</b>	<b>OU</b>	2"	1-1/4"	
<b>UP</b>	<b>PU</b>	1-1/2"	1-1/2"	
<b>UQ</b>	<b>QU</b>	1-1/2"	1-1/4"	
<b>UR</b>	<b>RU</b>	1-1/4"	1-1/4"	
<b>SAE Split Flange (motor)</b>				
<b>BB-Double</b>	1-1/2"		1-1/2"	
<b>CC-Double</b>	1-1/4"		1-1/4"	
<b>EE-Double</b>	1"		1"	
<b>FF-Double</b>	3/4"		3/4"	
<b>OD Tube Porting (pump)</b>				
<b>PQ</b>	<b>QP</b>	1-1/2"	1-1/4"	
<b>PR</b>	<b>RP</b>	1-1/4"	1-1/4"	
<b>OD Tube Porting (motor)</b>				
<b>NN-Double</b>	1-1/4"		1-1/4"	
<b>QQ-Double</b>	1"		1"	
<b>RR-Double</b>	3/4"		3/4"	
<b>Common Inlet Passage</b>				
<b>C</b>	<b>D</b>	No Ports		

<b>Code</b>	<b>10 – Connecting Shaft</b>	
<b>1</b>	Connecting Shaft	
For connecting tandem units		

 **WARNING:** This product can expose you to chemicals including lead or DEHP which are known to the state of California to cause cancer, birth defects, and other reproductive harm. [www.p65warnings.ca.gov](http://www.p65warnings.ca.gov)