

# Pump & Motor Division

PGP/PGM 500 Series  
Service Manual



ENGINEERING YOUR SUCCESS.



### **WARNING – User Responsibility**

FAILURE OR IMPROPER SELECTION OR IMPROPER USE OF THE PRODUCTS AND/OR SYSTEMS DESCRIBED HEREIN OR RELATED ITEMS CAN CAUSE DEATH, PERSONAL INJURY AND PROPERTY DAMAGE.

This document and other information from Parker Hannifin Corporation, its subsidiaries and authorized distributors provide product and/or system options for further investigation by users having technical expertise. It is important that you analyze all aspects of your application and review the information concerning the product or system in the current product catalog. Due to the variety of operating conditions and applications for these products or systems, the user, through its own analysis and testing, is solely responsible for making the products and systems and assuring that all performance, safety and warning requirements of the application are met.

The products described herein, including without limitation, product features, specifications, designs, availability and pricing, are subject to change by Parker Hannifin Corporation and its subsidiaries at any time without notice.

### **Offer of Sale**

The items described in this document are hereby offered for sale by Parker Hannifin Corporation, its subsidiaries or its authorized distributors. This offer and its acceptance are governed by the provisions stated in the "Offer of Sale".

© Copyright 2020, Parker Hannifin Corporation, All Rights Reserved



**WARNING:** This product can expose you to chemicals including lead or DEHP which are known to the state of California to cause cancer, birth defects, and other reproductive harm. [www.p65warnings.ca.gov](http://www.p65warnings.ca.gov)



# Table of Contents

<b>General Information</b> .....	1-4
<b>Single Pump</b> .....	1
<b>Use Genuine Parker Replacement Parts</b> .....	2
<b>Tool List</b> .....	3
<b>Seal Installation Tools</b> .....	4
<b>Exploded View</b> .....	5
<b>Bill of Materials</b> .....	6
<b>Disassembly Instructions</b> .....	7-10
<b>Assembly Instructions</b> .....	11-17
<b>Guidelines of Acceptable Wear</b> .....	18-19
<b>Fluid Recommendations</b> .....	20-22
<b>Start-up Procedure / Test Procedure</b> .....	23
<b>Offer of Sale</b> .....	27-28

 **WARNING:** This product can expose you to chemicals including lead or DEHP which are known to the state of California to cause cancer, birth defects, and other reproductive harm. [www.p65warnings.ca.gov](http://www.p65warnings.ca.gov)



# Single Pump

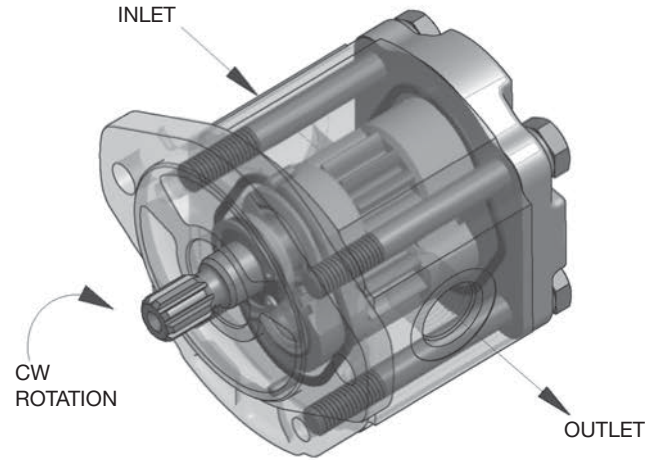
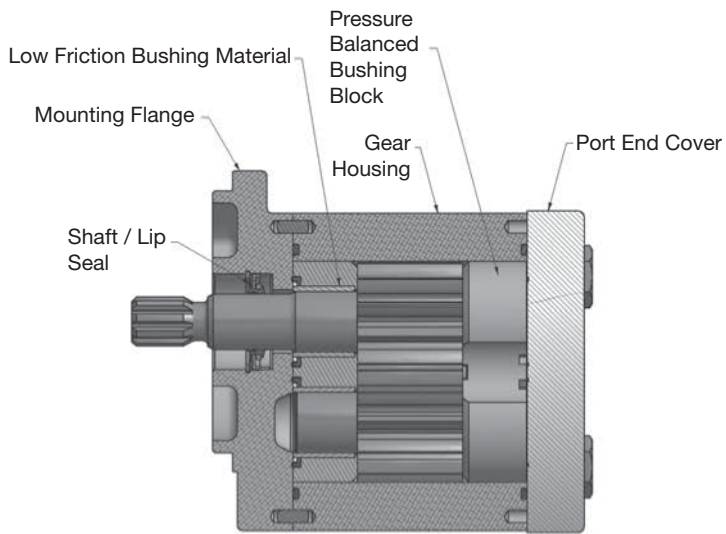
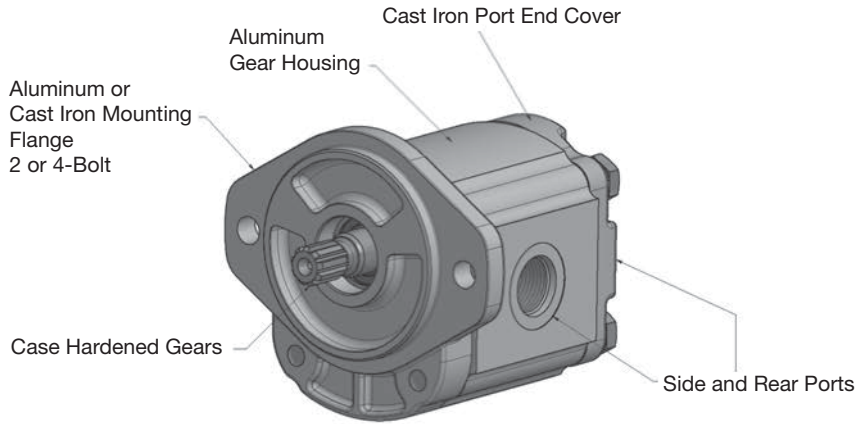

**WARNING:** This product can expose you to chemicals including lead or DEHP which are known to the state of California to cause cancer, birth defects, and other reproductive harm. [www.p65warnings.ca.gov](http://www.p65warnings.ca.gov)



## Use Genuine Parker Replacement Parts

These service instructions will familiarize you with Parker's single and multiple pumps, their component parts, the relative position of each part proper methods for assembly or disassembly of the units.

To facilitate the repair of these units, and before any work is done, we suggest that you first read all of the steps used in disassembly and assembly.

Dirt is the enemy of any hydraulic system. The first requirement of good maintenance of hydraulic equipment is cleanliness. **MAKE SURE YOU DISASSEMBLE AND ASSEMBLE YOUR HYDRAULIC EQUIPMENT IN A CLEAN AREA.**

The pictures show Model PGP511. Notes in the text cover variations between this unit and the other models.

It is important to airblast all parts and wipe them with a clean, lintless cloth before assembly.

**USE CAUTION IN GRIPPING ALL PARTS IN THE VISE TO AVOID DAMAGING MACHINED SURFACES**

A pump must be driven in the direction of rotation for which it was built; otherwise, the pressure will blow the shaft seal. Check the exploded view and notes at right for proper direction of rotation.

### Parker's Replacement Parts

Parker's replacement parts are of original equipment standards. For assured quality of material and workmanship, and for compatibility in assembly, **USE ONLY GENUINE PARTS.**

Check all replacement parts before installing them to be certain that they were not damaged in shipment.

 **WARNING:** This product can expose you to chemicals including lead or DEHP which are known to the state of California to cause cancer, birth defects, and other reproductive harm. [www.p65warnings.ca.gov](http://www.p65warnings.ca.gov)

---



**General Information**

Tool List	
Arbor press	Snap ring pliers
Awl	Prick punch
Clean, lintless cloths	Scale (1/32" or 1/64" graduations)
Deburring tool (an old file with cutting teeth ground off)	Small screw driver
Machinist's hammer	Torque wrench
Soft hammer	Vise with 6" minimum opening
Medium grit carborundurn stone	Bar for lip seal installation
Seal removal tool (See A)	Special mylar sleeve (See B)
Oil and Grease	

**A Seal Removal Tool**

Easily made from an old screw driver. Heat the tip and bend as shown. Grind the tip to fit the notch behind the shaft seal.

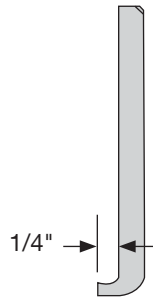

**B Special Mylar Sleeve**

The special mylar sleeve is used to insert the drive shaft through the lip seal without damage. The drawing and chart give details for making this special tool.

NOTE: Please see tool list for lip seal bar installation.

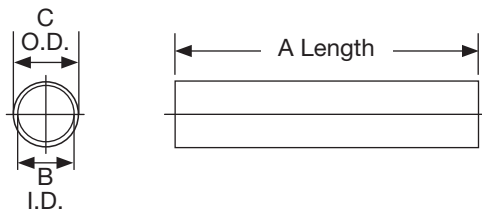

Pump/Motor	A	B	C
PGP/PGM 505	2.71"-3.190"	0.631"-0.634"	0.634"- 0.635"
PGP/PGM 511	2.940"-3.000"	0.690"-0.694"	0.698"-0.702"

**WARNING:** This product can expose you to chemicals including lead or DEHP which are known to the state of California to cause cancer, birth defects, and other reproductive harm. [www.p65warnings.ca.gov](http://www.p65warnings.ca.gov)



**Seal Installation Tools**

Constructed from mild steel

Pump/Motor	SEC	Description	A	B	C	D	E	F	G	H
PGP/PGM 505	A1, A2	Integral Shaft	0.946"	3.500"	0.630"	0.275"	0.748"	0.040"	30°	0.060"
PGP/PGM 505	L5	Continental Shaft	1.024"	3.500"	0.630"	0.275"	0.748"	0.040"	30°	0.060"

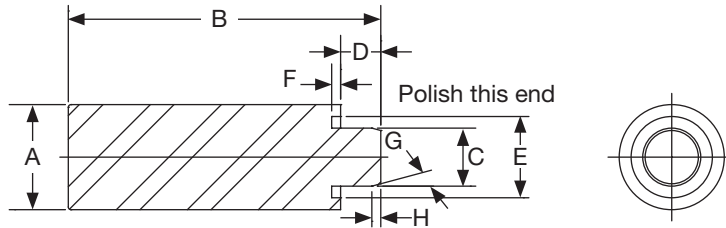

Pump/Motor	SEC	Description	A	B	C	D	E	F
PGP/PGM 511	H2	Integral Shaft	0.786"	1.368"	0.295"	0.974"	0.500"	3.250"
PGP/PGM 511	H3	Integral Shaft	0.786"	1.368"	0.295"	0.516"	0.500"	4.000"

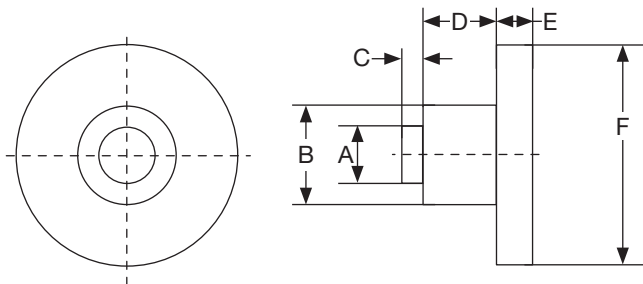

Pump/Motor	SEC	Description	A	B	C	D	E	F	G
PGP/PGM 511	L2	Continental Shaft	1.800"	1.400"	1.750"	2.000"	3.200"	8.250"	0.750"
PGP/PGM 511	L3	Continental Shaft	1.800"	1.400"	2.500"	2.750"	3.200"	8.250"	0.750"

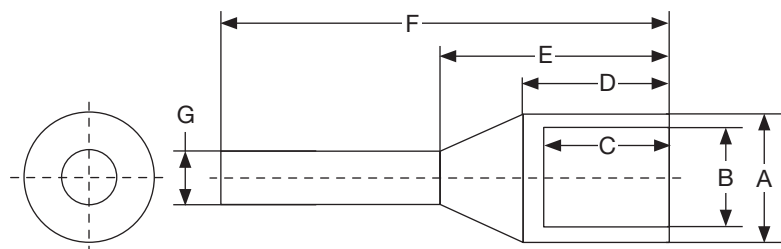

**WARNING:** This product can expose you to chemicals including lead or DEHP which are known to the state of California to cause cancer, birth defects, and other reproductive harm. [www.p65warnings.ca.gov](http://www.p65warnings.ca.gov)



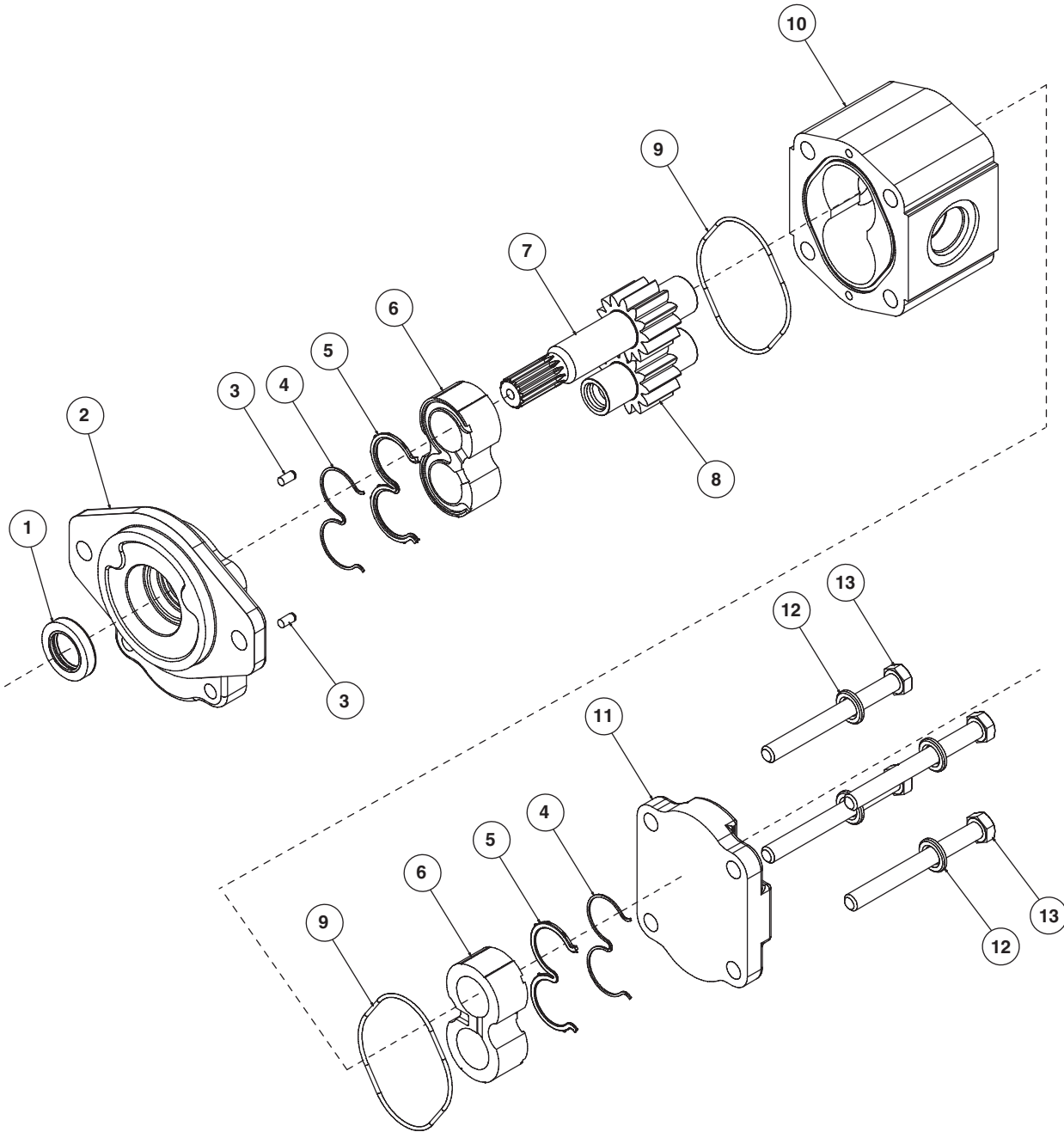

**WARNING:** This product can expose you to chemicals including lead or DEHP which are known to the state of California to cause cancer, birth defects, and other reproductive harm. [www.p65warnings.ca.gov](http://www.p65warnings.ca.gov)





**Bill of Materials**

ITEM	DESCRIPTION	QTY.
1	Lip Seal	1
2	Mounting Flange	1
3	Dowel Pin	2
4	Backup Seal	2
5	Channel Seal	2
6	Thrust Block	2
7	Drive Gear	1
8	Driven Gear	1
9	O-Ring Seal	2
10	Gear Housing	1
11	Port End Cover	1
12	Washer	4
13	Capscrew	4

 **WARNING:** This product can expose you to chemicals including lead or DEHP which are known to the state of California to cause cancer, birth defects, and other reproductive harm. [www.p65warnings.ca.gov](http://www.p65warnings.ca.gov)



## Start Disassembly

**CAUTION:**

1. If prying off sections becomes necessary, take extreme care not to mar or damage machined surfaces. Excessive force while prying can result in misalignment and seriously damage parts.
2. If parts are difficult to fit during assembly, tap gently with a soft hammer. (Never use an iron hammer.)
3. Handle with care to avoid damage to the journals or teeth. Avoid touching gear journals.

- 1) Place the pump in a vise with the drive shaft pointing down (**Fig. 1**). Match-mark all sections. Be sure to align these marks when reassembling.

DO NOT GRIP ON OR NEAR ANY MACHINED SURFACES DURING ASSEMBLY OR DISASSEMBLY.



Figure 1

- 2) Remove four bolts and cap screws on single units or the 4 hex nuts, studs and washers of multiple units (**Fig. 2**). Use an impact driver in a cross-pattern. Inspect threads and cap screws for wear.

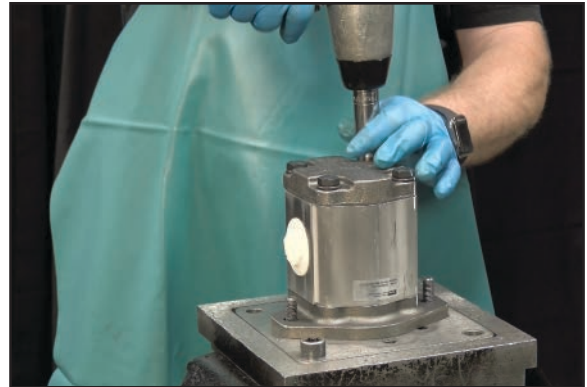



Figure 2

- 3) Lift off the port end cover and look at underside for any damage (**Fig. 3**). If prying is necessary, be careful not to damage the machined surfaces.



Figure 3

 **WARNING:** This product can expose you to chemicals including lead or DEHP which are known to the state of California to cause cancer, birth defects, and other reproductive harm. [www.p65warnings.ca.gov](http://www.p65warnings.ca.gov)

- 4) Remove gear housing (**Fig. 4**). If prying with screwdriver is necessary, be careful not to damage the machined surfaces.



Figure 4

Example of excessive cutout on a gear housing, circled in yellow. (**Fig. 5**).

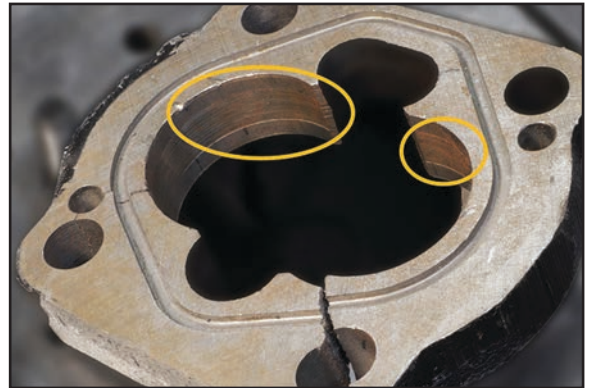

Figure 5

- 5) Mark bushing blocks top and bottom. Remove thrust plate. (**Fig. 6**). Examine and replace if necessary. See wear guide [page 18](#).

Below are some examples of damaged plates (**Fig. 7**):



Figure 6

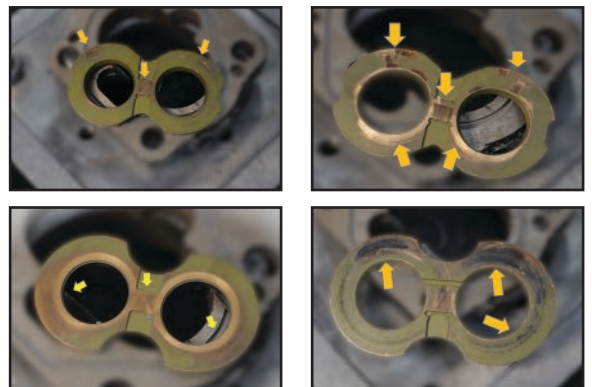

Figure 7

**WARNING:** This product can expose you to chemicals including lead or DEHP which are known to the state of California to cause cancer, birth defects, and other reproductive harm. [www.p65warnings.ca.gov](http://www.p65warnings.ca.gov)

- 6) Before removing gears, draw a match mark in center of the gear teeth. (**Fig. 8**). Doing so will help make sure they are placed back in the correct position when reassembling the pump.
- 7) Carefully remove idler gear first. (**Fig. 9**). Avoid tapping the gear teeth together or against other hardened surfaces.
- 8) Next, remove the drive gear (**Fig. 10**). Keep these gears together because they are a matched set. Examine each for wear and replace if necessary. See wear guide on [page 18](#).
- 9) Carefully remove the thrust block from the bottom of body (**Fig. 11**). Inspect all bushings in thrust block for scoring or discoloration and replace if necessary.



Figure 8



Figure 9



Figure 10



Figure 11

**⚠ WARNING:** This product can expose you to chemicals including lead or DEHP which are known to the state of California to cause cancer, birth defects, and other reproductive harm. [www.p65warnings.ca.gov](http://www.p65warnings.ca.gov)



- 10)** If equipped, remove the snap ring (**Fig. 12**).  
Snap ring is located in front of the shaft seal.



Figure 12

- 11)** Pry out the lip seal (**Fig. 13**). Be careful not to damage seal bore in pump body.

See tool list on [page 3](#) for prying device.



Figure 13

- 12)** Remove, replace section seal and examine for debris or wear. (**Fig. 14**).  
When replacing the seal, grease thoroughly and insert firmly into the gear housing before reassembling. Contact an authorized Parker Service Center to determine and order the proper seal kit for your pump.

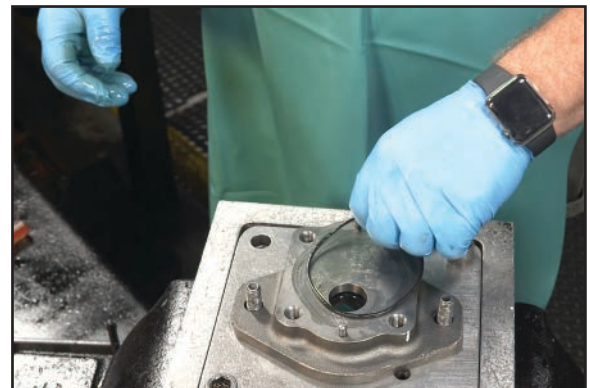



Figure 14

 **WARNING:** This product can expose you to chemicals including lead or DEHP which are known to the state of California to cause cancer, birth defects, and other reproductive harm. [www.p65warnings.ca.gov](http://www.p65warnings.ca.gov)

### Start Assembly

- 1) Before start, clean all machined surfaces and make sure are free of debris.
- 2) Prep new lip seal for replacement (**Fig. 1**).
- 3) Grease new lip seal (**Fig. 2**). Coat the outer edge of the lip seal and its recess with non-hardening sealant or equivalent before replacing.
- 4) Replace lip seal (**Fig. 3 & 4**). With the metal side of the lip seal up, press it into the mounting flange side of the shaft end cover with an arbor press and bar (see Tool List on [page 3](#)). Be careful not to damage the lip of the seal.  
Press in until flush with the recess. Wipe off excess sealant.



Figure 1



Figure 2



Figure 3



Figure 4

**WARNING:** This product can expose you to chemicals including lead or DEHP which are known to the state of California to cause cancer, birth defects, and other reproductive harm. [www.p65warnings.ca.gov](http://www.p65warnings.ca.gov)

- 5) Replace bearing (**Fig. 5**). Place new bearing over lip seal for installation.

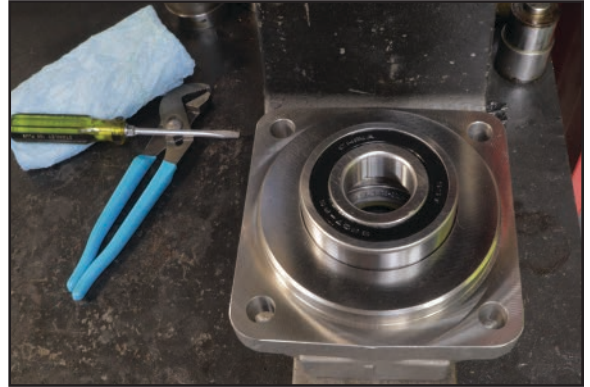

Figure 5

- 6) Press new bearing over lip seal (**Fig. 6 & 7**). Using arbor press, seat new bearing flush with lip seal.



Figure 6



Figure 7

 **WARNING:** This product can expose you to chemicals including lead or DEHP which are known to the state of California to cause cancer, birth defects, and other reproductive harm. [www.p65warnings.ca.gov](http://www.p65warnings.ca.gov)



- 7) Assemble the snap ring (**Fig. 8 & 9**). Using snap ring pliers, seat new snap ring on top of bearing and lip seal.

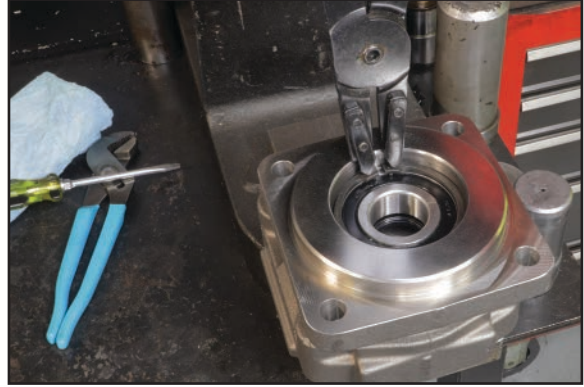

Figure 8



Figure 9

- 8) Mount shaft end cover facing down in a vise (**Fig. 10**).

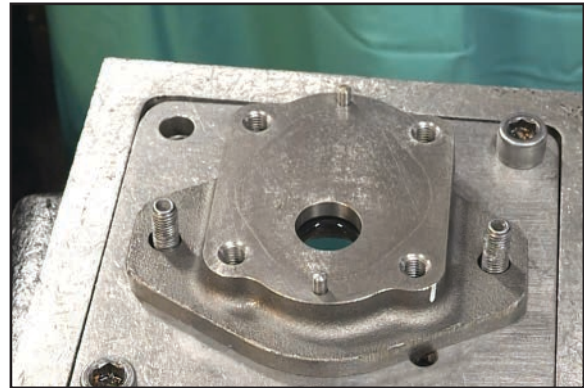

Figure 10

- 9) Re-affix or replace section seal (**Fig. 11**). Verify both sides of the section seal are free of debris. If need to replace, grease the new section seal and insert firmly into the grooves in both sides of the gear housing.

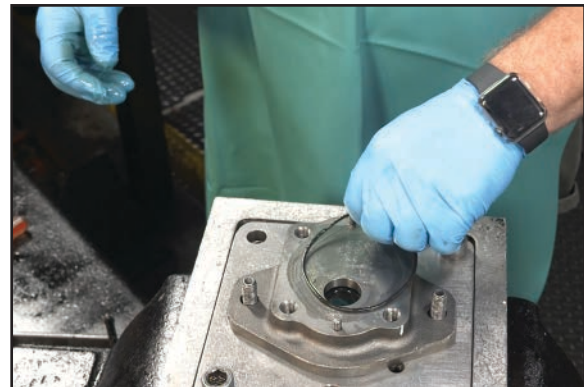

Figure 11

**⚠ WARNING:** This product can expose you to chemicals including lead or DEHP which are known to the state of California to cause cancer, birth defects, and other reproductive harm. [www.p65warnings.ca.gov](http://www.p65warnings.ca.gov)



- 10) Install gear housing (**Fig. 12**).  
Be sure to line up witness marks as press down.



Figure 12

- 11) Assemble new sealing parts in thrust block and verify orientation (**Fig. 13**).



Figure 13

 **WARNING:** This product can expose you to chemicals including lead or DEHP which are known to the state of California to cause cancer, birth defects, and other reproductive harm. [www.p65warnings.ca.gov](http://www.p65warnings.ca.gov)

The sealing parts can be fixed with grease. (see below for steps to install sealing parts correctly)

- i. Turn the thrust blocks so the seal groove faces up
- ii. Place the soft black into the seal groove with the flat side down
- iii. Place the hard nylon back-up seal, flat side up, into the groove on top of the rubber seal

Pump Thrust Block - Back Side (**Fig. 14**) & (**Fig. 15**)

Pump Thrust Block - Front Side (**Fig. 16**)

Motor Thrust Block - Back Side (**Fig. 17**) & (**Fig. 18**)

Motor Thrust Block - Front Side (**Fig. 19**)

The proper seal installation is very important. If these seals are assembled upside down, they will most likely fail in a short period of time under system pressure.



Figure 14  
Pump Thrust Block - Back Side



Figure 15

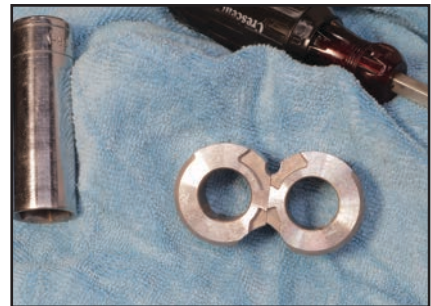

Figure 16  
Pump Thrust Block - Front Side



Figure 17  
Pump Thrust Block - Back Side



Figure 18



Figure 19  
Pump Thrust Block - Front Side

**WARNING:** This product can expose you to chemicals including lead or DEHP which are known to the state of California to cause cancer, birth defects, and other reproductive harm. [www.p65warnings.ca.gov](http://www.p65warnings.ca.gov)

- 12) Assemble the front thrust block into port end cover (Fig. 20).**  
Orientation is rotation sensitive for pumps and the seals should be pointed down and facing the high pressure side of the pump, the pressure port. Push down until thrust block is flush with the shaft end.



Figure 20

- 13) Insert drive gear (Fig. 21).**  
Use a lubricated seal guide, slide over the drive gear to protect teeth during assembly. Insert shaft fully through port end cover until seal guide falls through the underside and drive gear is seated firmly at the bottom of port end cover.



Figure 21

Example of a shaft seal guide protecting a gear (Fig. 22).



Figure 22

- 14) Insert idler gear (Fig. 23).** Push through thrust block and port end cover, making sure to line up the witness marks.



Figure 23

**WARNING:** This product can expose you to chemicals including lead or DEHP which are known to the state of California to cause cancer, birth defects, and other reproductive harm. [www.p65warnings.ca.gov](http://www.p65warnings.ca.gov)



**15)** Install top thrust block (**Fig. 24**). Use grease to hold into groove. Then, place rear thrust block over top of gears. It is important that the pressure plate be installed with inlets pointing toward discharge side.



Figure 24

**16)** Install port end cover. (**Fig. 25**). Be sure to line up witness marks.



Figure 25

**17)** Install hardware (bolts and washers) (**Fig. 26**). Thread the fasteners into the port end cover and tighten in a cross pattern, first by hand then with an impact tool.



Figure 26

**18)** Torque fasteners in cross-pattern (**Fig. 27**). Do not lubricate fastener threads before assembly. Follow below torque guide.



Figure 27

500 Series Torque Guide	
Series	Lbs-ft
PGP502/PGM502	15
PGP505/PGM505	22.5
PGP511/PGM511	36
PGP517/PGM517	83

**⚠ WARNING:** This product can expose you to chemicals including lead or DEHP which are known to the state of California to cause cancer, birth defects, and other reproductive harm. [www.p65warnings.ca.gov](http://www.p65warnings.ca.gov)

**Gear Housings**

Wear in excess of .005" cut-out necessitates replacement of the body. Place a straight-edge across bore. If you can slip a .005" feeler gauge under the straight-edge in the cut-out area, replace the body.

Pressure pushes the gears against the housing on the low pressure side. As the hubs and bushings wear, the cut-out becomes more pronounced. Excessive cut-out in a short period of time indicates excessive pressure or oil contamination. If the relief valve settings are within prescribed limits, check for shock pressures or tampering. When the cut-out is moderate, .005" or less, the gear housing is in good condition and may be reused.

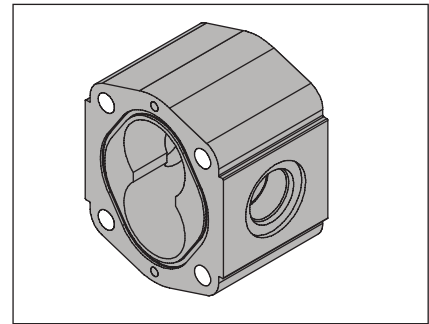

**Gears**

Any scoring on gear hubs necessitates replacement. Scoring, grooving, or burring of the outside diameter of the teeth requires replacement. Nicking, grooving, or fretting of teeth surfaces also necessitates replacement.



**Drive Shafts**

Replace if there is any wear detectable by touch in the seal area or at the drive coupling. The maximum allowable wear is .002". Wear in the shaft seal area indicates oil contamination. Wear or damage to splines, keys, or keyways necessitates replacement.

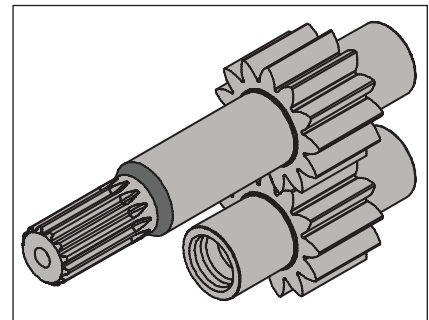

**Bushing Blocks**

The bushing blocks seal the gear section at the sides of the gears. Wear here will allow internal slippage, that is, oil will bypass within the pump. A maximum of .002" wear is allowable. Replace bushing blocks if they are scored, eroded or pitted. Check center of bushing blocks where the gears mesh. Erosion here indicates oil contamination.

Pitted bushing blocks indicate cavitation or oil aeration. Discolored balance plates indicate overheating, likely due to insufficient oil.



- 505  1 piece
- 511  2 pieces

 **WARNING:** This product can expose you to chemicals including lead or DEHP which are known to the state of California to cause cancer, birth defects, and other reproductive harm. [www.p65warnings.ca.gov](http://www.p65warnings.ca.gov)

**Seals and Gaskets**

Replace all rubber and polymer seals, including all o-rings, thrust block channel seals, shaft seal and gasket seals.



**Checks**

Examine the checks, if unit has them, in the mounting flange to make sure that they are tight, and free of contamination



**⚠ WARNING:** This product can expose you to chemicals including lead or DEHP which are known to the state of California to cause cancer, birth defects, and other reproductive harm. [www.p65warnings.ca.gov](http://www.p65warnings.ca.gov)

## Hydraulic Oil Recommendations

When choosing your Hydraulic Oil, duty cycle and oil temperature must be factored in to optimize your system performance. Since hydraulic systems often work under extreme temperature changes, especially in moderate to severe duty cycles, the lubrication qualities of the oil in tight tolerance components is even more critical.

Viscosity choice is always a compromise; the fluid must be thin enough to flow easily but thick enough to seal and maintain a lubricating film between bearing and sealing surfaces. This film of oil helps to reduce friction and heat, which can ultimately lead to component damage.

Fluid temperature does affect viscosity. When choosing a fluid, it is important to consider the start-up and operating temperatures of the hydraulic system. In general, as the fluid warms, it gets thinner and its viscosity decreases. At the highest temperatures, the fluid must be thick enough to provide lubrication and minimize internal leakage. Low viscosity leads to the following problems:

- Higher leakage across all sealing gaps in the pump leading to lower volumetric efficiencies and heat.
- Heat will cause loss of lubrication and will create severe wear because of metal to metal contact, causing premature failure of the gears, thrust plates and bushing blocks.

The opposite is true when the fluid cools, its viscosity increases. At the lowest temperatures, the fluid must be thin enough to flow readily. High viscosity oil leads to the following problems:

- Sealing and lubrication gaps not being filled, loss of lubrication
- Filling losses occur which causes cavitation damage to the pump

Under normal operating temperatures it is recommended to keep the temperature of the hydraulic fluid in the range of 120°F to 140°F (49°C to 60°C). Fluids may break down or oxidize at high temperatures, which leads to varnish or sludge deposits in the system and also reduces lubricity and results in reduced life of the unit. As a rule of thumb, operating temperatures over 176°F (80°C) reduce the service life by half for every 50°F (10°C) temperature increase, and should be avoided.

## Petroleum Oils (Mineral-based)

### Viscosity Recommendations

Optimum operating viscosity is considered to be about 100 SUS (20 cSt).

Minimum approximately: 50 - 60 SUS (7.5 - 10 cSt)

Maximum at start up approximately: 7500 SUS (1600 cSt)

### Recommended Viscosity Grades:

Grade	Viscosity at 100°F (40°C)	Viscosity at 210°F (100°C)
ISO 32	165 SUS (32 cSt)	44 SUS (5 cSt)
ISO 46	240 SUS (46 cSt)	49 SUS (7 cSt)
SAE 10	150 SUS (32 cSt)	41 SUS (4 cSt)
SAE 20	300 SUS (71 cSt)	51 SUS (7 cSt)

Other Desirable Properties	Additives Usually Recommended:
Viscosity Index: 90 minimum	Rust and Oxidation (R & O) Inhibitors
Aniline Point: 175 minimum	Foam Depressant

**NOTE:** Antiwear (AW) additives are not necessarily recommended. In some instances the presence of zinc compounds can actually be harmful to copper, bronze, or brass components used in the system. The use of AW oil is optional with our gear units.

### General Recommendations

High quality hydraulic oils are essential for satisfactory performance and long life of any hydraulic system. Such oils are usually prepared from highly refined, turbine oil stocks with which select additives are compounded. We suggest following the manufacturer's specifications or the recommendations of a reputable oil supplier for the specific oil requirements on your machine.

A high viscosity oil will generally give better performance and life than a thin oil. Oil of around 100 SUS (20 cSt) will give optimum performance. Your selection should be as near to optimum as possible at operating temperature but not so heavy at start-up as to cause cavitation. Cold start-up procedures which allow the use of heavier oils should prove worthwhile by increasing pump life. The oil must be clean and contain less than 0.1% water.

 **WARNING:** This product can expose you to chemicals including lead or DEHP which are known to the state of California to cause cancer, birth defects, and other reproductive harm. [www.p65warnings.ca.gov](http://www.p65warnings.ca.gov)



## Hydraulic Oil Recommendations (Continued)

### Petroleum Oils (Mineral-based) (Continued)

#### Operating Temperature

The optimum oil operating temperature is in the range of 120°-140°F (49°-60°C). Oil operating temperature should not exceed 200°F (93°C) with a maximum of 180°F (82°C) generally recommended. If the oil temperature will be above 180°F (82°C) for significant periods of time, then Viton (FKM) seals should be used. High temperatures may result in rapid oil deterioration and may point out the need for an oil cooler or a larger reservoir. The nearer to optimum temperature, the longer the service life will be of the oil, pump and other components.

#### Cold Weather Operation

Oils for use in cold weather should have a viscosity not exceeding 7500 SUS (1620 cSt) at the minimum start-up temperature and a pour point of at least 20°F (7°C) below that temperature. Experience on the Alaskan North Slope has been satisfactory without using special oils or fluids. Start-up procedures must allow for a gradual warm-up and equipment should not be operated at full pressure until the oil reaches a reasonably fluid state.

#### Inlet Vacuum

Vacuum measured at the inlet port of the pump generally should not exceed 5 in. (13 cm) Hg. Higher vacuum can result in cavitation which may severely damage the pump. A usually acceptable rule of thumb is that the inlet line velocity should not exceed 8 fps (2.5 m/s). A long inlet line or the use of several fittings may necessitate increasing the line size. We suggest that each inlet port of a tandem pump have its own line from the reservoir.

#### Reservoir

Reservoir capacity in gallons should at least equal total pump output in GPM. When filling the reservoir, oil should pass through a 100-mesh screen. Pour only clean oil from clean containers into the reservoir. The reservoir should have a breather to allow air in or out. The filler cap and breather should be sealed to prevent moisture from entering. A hydraulic oil water content of as little as 0.1% can cause damage to hydraulic components.

#### Filtration

Good filtration assures improved service life at today's high operating pressures. System filtration is recommended that will maintain a contamination level according to ISO 4406:

ISO 4406	psi	bar
21/19/16	2000	140
19/17/14	3000	210
17/15/12	4000	275

The specific filter recommendation should come from your equipment manufacturer or filter supplier.

A 100 mesh screen should generally be used in the suction line leading to the pump. It should be of sufficient size to handle twice the pump capacity. The screen must be cleaned and checked regularly to avoid pump and system damage.

Oil and filters should be changed on a regular schedule and the system flushed in accordance with the original equipment manufacturer's recommendations. Reservoir air breather filters should be cleaned periodically.

**Filtration is not a substitute for practicing cleanliness and proper preventive maintenance.**

 **WARNING:** This product can expose you to chemicals including lead or DEHP which are known to the state of California to cause cancer, birth defects, and other reproductive harm. [www.p65warnings.ca.gov](http://www.p65warnings.ca.gov)





## Hydraulic Oil Recommendations (Continued)

### Water Base Fire Resistant Fluids

Two types of water base fluids (WBF) may be used with our gear pumps and motors. Both types of WBF come in various viscosity grades. Select the grade best suited to the equipment and its operation in terms of pressure, speed, temperature, duty cycle, etc. The fluid used should be recommended by the O.E.M. or a reputable fluid supplier.

Operations outside the range of 400 to 2000 rpm and over 3000 psi (2000/2500 psi in the wider gear widths) should be reviewed with your Parker sales representative.

### Water-in Oil (60/40) invert Emulsions

Invert emulsions are approved for use with our bushing style pumps at pressures up to 3000 psi or 500 psi below catalog rated pressures, whichever is lower.

### Water Glycol Solutions

Water glycol solutions of the types normally used in hydrostatic systems are recommended for use with our bushing style pumps. These consist of about 60% glycol and about 40% water with additives to improve lubricity and other characteristics. Pressures up to 3000 psi are approved, depending on the gear width.

### WBF Filtration

Filtration that seems to give the best results consists of a 100-mesh inlet screen and a return line filter. For water base fluids, the inlet screen should be sized up three to four times the pump capacity. The return line filter should be of a rating and size recommended by the fluid and filter manufacturers to achieve a recommended ISO contamination level.

**NOTE:** Finer filtration may be required by other components in the system.

### High Water Base Fluids (HWBF)

The use of 95/5 emulsion is not recommended.

### Comments: Use of other oils and fluids

#### Biodegradable Oil (Vegetable-Based)

Oils of this type with properties similar to recommended petroleum oils may be used. Performance, pressure ratings and durability are not adversely affected in bushing style pumps.

#### Automatic Transmission Fluid (ATF)

In general, these oils have low viscosity and may be used only at reduced operating pressures and oil temperatures.

#### Diesel Fuel, Kerosene, Coal Oil

Although sometimes used as a dilutant for cold weather operations, their use is not recommended because they are insufficiently refined products.

#### Transformer Oil

Sometimes used for extremely cold weather operation. It is not generally recommended as it becomes too thin at normal operating temperatures. Oil to U.S. Military Spec MIL-H-5606 is in this category.

### Operating Limits Generally Recommended with Various Fluids

Fluid	Max. Operating Temp.	Max. Inlet Line Velocity	Max. Inlet Vacuum
Petroleum Oil	180°F (82°C)	8 fps (2.5m/s)	5" (13cm) Hg
WIO Emulsion	150°F (65°C)	4 fps (1.2m/s)	0" (0cm) Hg
Water Glycol	150°F (65°C)	4 fps (1.2m/s)	0" (0cm) Hg

**NOTE:** These figures represent generally accepted maximums and will not prove satisfactory in all installations. For very severe duty cycles, it will likely be advantageous to design and operate the system at something less than these maximum limits.

- DO NOT USE ANY TYPE OF FLUID NOT RECOMMENDED IN THIS BULLETIN WITHOUT FIRST CONSULTING OUR PRODUCT SUPPORT DEPT
- OBTAIN YOUR FINAL FLUID RECOMMENDATION FROM YOUR FLUID SUPPLIER

 **WARNING:** This product can expose you to chemicals including lead or DEHP which are known to the state of California to cause cancer, birth defects, and other reproductive harm. [www.p65warnings.ca.gov](http://www.p65warnings.ca.gov)



## Recommended Start-up Procedure for New or Rebuilt Pump

Before installing a new or rebuilt pump, back off the main relief valve until the spring tension on the adjusting screw is relieved. This will avoid the possibility of immediate damage to the replacement unit in the event that the relief valve setting had been increased beyond the recommended operating pressure, prior to removing the old unit.

Before connecting any lines to the pump, fill all ports with clean oil to provide initial lubrication. This is particularly important if the unit is located above the oil reservoir.

After connecting the lines and mounting the replacement unit, operate the pump at least two minutes at no load and at low rpm (400 min.) During this break-in period, the unit should run free and not develop an excessive amount of heat. If the unit operates properly, speed and pressure can then be increased to normal operating settings.

Reset the main relief valve to its proper setting while the pump is running at maximum operating engine (motor) speed for the vehicle.

**ALWAYS USE AN ACCURATE GAUGE WHEN ADJUSTING THE RELIEF VALVE PRESSURE SETTING.**

## Recommended Test Procedure

Make certain that there is an adequate supply of oil for the pump; at least one gallon of oil for each gpm of pump capacity.

If one section of a tandem pump is being tested, make sure that all other sections not being tested are adequately supplied with oil. If any of the other sections run dry, or if plugs are left in ports, serious and permanent damage will result.

The oil should be a good quality hydraulic oil rated at 150 SSU at 100°F, with the oil temperature held at 120°F plus or minus 50°F. (Test procedures are described in detail in SAE handbooks; see Hydraulic Power Pump Test Procedure, SAE J745c.)

The feed line must be of adequate size with no more than 5" mercury vacuum adjacent to the pump inlet. As a rule, the feed line must provide a feed flow velocity not in excess of 8 feet per second.

Feeding hot oil into a cold pump may cause the pump to seize. Jog the pump by momentarily starting and stopping repeatedly the driving engine or motor to gradually equalize pump and oil temperatures.

Run the pump at least two minutes at no load and moderate speed (not over 1500 rpm). If the pump becomes excessively hot, shut down immediately and locate the problem source.

Gradually increase pressure on pump, in 500 psi increments until the desired test pressure has been reached. This should take about five minutes.

Delivery should run close to rated catalog performance figures, which are averaged from testing several pumps. A 5% lower reading may be used as a rated minimum if new or relatively new parts have been used. When rebuilding the pump with parts from the original pump, which, while worn, appear satisfactory for reuse, a 10% or 15% lower reading may be permitted, depending on the performance expected from the equipment. One's own experience will prove the best guide here.

At test speeds other than 1800 rpm, gpm delivery will vary almost proportionately, but the same (drop-off) figures should be used.

Be sure to run the pump in the direction for which it was designed and built. Driving the pump in the wrong direction will build up pressure behind the shaft seal, damaging it and necessitating replacement.

After completing testing procedures, the pump is ready for installation and immediate duty operation on equipment. Again, it must be remembered that to prevent seizure, hot oil must not be fed into a cold pump.



**WARNING:** This product can expose you to chemicals including lead or DEHP which are known to the state of California to cause cancer, birth defects, and other reproductive harm. [www.p65warnings.ca.gov](http://www.p65warnings.ca.gov)









## Offer of Sale

**1. Definitions.** As used herein, the following terms have the meanings indicated.

- Buyer:** means any customer receiving a Quote for Products from Seller.
- Goods:** means any tangible part, system or component to be supplied by the Seller.
- Products:** means the Goods, Services and/or Software as described in a Quote provided by the Seller.
- Quote:** means the offer or proposal made by Seller to Buyer for the supply of Products.
- Seller:** means Parker Hannifin Corporation, including all divisions and businesses thereof.
- Services:** means any services to be supplied by the Seller.
- Software:** means any software related to the Products, whether embedded or separately downloaded.
- Terms:** means the terms and conditions of this Offer of Sale or any newer version of the same as published by Seller electronically at [www.parker.com/saleterms](http://www.parker.com/saleterms).

**2. Terms.** All sales of Products by Seller are contingent upon, and will be governed by, these Terms and, these Terms are incorporated into any Quote provided by Seller to any Buyer. Buyer's order for any Products whether communicated to Seller verbally, in writing, by electronic data interface or other electronic commerce, shall constitute acceptance of these Terms. Seller objects to any contrary or additional terms or conditions of Buyer. Reference in Seller's order acknowledgement to Buyer's purchase order or purchase order number shall in no way constitute an acceptance of any of Buyer's terms of purchase. No modification to these Terms will be binding on Seller unless agreed to in writing and signed by an authorized representative of Seller.

**3. Price; Payment.** The Products set forth in Seller's Quote are offered for sale at the prices indicated in Seller's Quote. Unless otherwise specifically stated in Seller's Quote, prices are valid for thirty (30) days and do not include any sales, use, or other taxes or duties. Seller reserves the right to modify prices at any time to adjust for any raw material price fluctuations. Unless otherwise specified by Seller, all prices are F.C.A. Seller's facility (INCOTERMS2010). All sales are contingent upon credit approval and payment for all purchases is due thirty (30) days from the date of invoice (or such date as may be specified in the Quote). Unpaid invoices beyond the specified payment date incur interest at the rate of 1.5% per month or the maximum allowable rate under applicable law.

**4. Shipment; Delivery;** Title and Risk of Loss. All delivery dates are approximate. Seller is not responsible for damages resulting from any delay. Regardless of the manner of shipment, delivery occurs and title and risk of loss or damage pass to Buyer, upon placement of the Products with the shipment carrier at Seller's facility. Unless otherwise agreed, Seller may exercise its judgment in choosing the carrier and means of delivery. No deferment of shipment at Buyer's request beyond the respective indicated shipping date will be made except on terms that will indemnify, defend and hold Seller harmless against all loss and additional expense. Buyer shall be responsible for any additional shipping charges incurred by Seller due to Buyer's acts or omissions.

**5. Warranty.** The warranty related to the Products is as follows: (i) Goods are warranted against defects in material or workmanship for a period of eighteen (18) months from the date of delivery or 2,000 hours of use, whichever occurs first; (ii) Services shall be performed in accordance with generally accepted practices and using the degree of care and skill that is ordinarily exercised and customary in the field to which the Services pertain and are warranted for a period of six (6) months from the completion of the Services by Seller; and (iii) Software is only warranted to perform in accordance with applicable specifications provided by Seller to Buyer for ninety (90) days from the date of delivery or, when downloaded by a Buyer or end user, from the date of the initial download. All prices are based upon the exclusive limited warranty stated above, and upon the following disclaimer: **DISCLAIMER OF WARRANTY: THIS WARRANTY IS THE SOLE AND ENTIRE WARRANTY**

**PERTAINING TO PRODUCTS. SELLER DISCLAIMS ALL OTHER WARRANTIES, EXPRESS AND IMPLIED, INCLUDING DESIGN, NON INFRINGEMENT, MERCHANTABILITY, AND FITNESS FOR A PARTICULAR PURPOSE. SELLER DOES NOT WARRANT THAT THE SOFTWARE IS ERROR-FREE OR FAULT-TOLERANT, OR THAT BUYER'S USE THEREOF WILL BE SECURE OR UNINTERRUPTED. BUYER AGREES AND ACKNOWLEDGES THAT UNLESS OTHERWISE AUTHORIZED IN WRITING BY SELLER THE SOFTWARE SHALL NOT BE USED IN CONNECTION WITH HAZARDOUS OR HIGH RISK ACTIVITIES OR ENVIRONMENTS. EXCEPT AS EXPRESSLY STATED HEREIN, ALL PRODUCTS ARE PROVIDED "AS IS".**

**6. Claims; Commencement of Actions.** Buyer shall promptly inspect all Products upon receipt. No claims for shortages will be allowed unless reported to the Seller within ten (10) days of delivery. Buyer shall notify Seller of any alleged breach of warranty within thirty (30) days after the date the non-conformance is or should have been discovered by Buyer. Any claim or action against Seller based upon breach of contract or any other theory, including tort, negligence, or otherwise must be commenced within twelve (12) months from the date of the alleged breach or other alleged event, without regard to the date of discovery.

**7. LIMITATION OF LIABILITY. IN THE EVENT OF A BREACH OF WARRANTY, SELLER WILL, AT ITS OPTION, REPAIR OR REPLACE THE NON-CONFORMING PRODUCT, RE-PERFORM THE SERVICES, OR REFUND THE PURCHASE PRICE PAID WITHIN A REASONABLE PERIOD OF TIME. IN NO EVENT IS SELLER LIABLE FOR ANY SPECIAL, INDIRECT, INCIDENTAL OR CONSEQUENTIAL DAMAGES ARISING OUT OF, OR AS THE RESULT OF, THE SALE, DELIVERY, NON-DELIVERY, SERVICING, NON-COMPLETION OF SERVICES, USE, LOSS OF USE OF, OR INABILITY TO USE THE PRODUCTS OR ANY PART THERE OF, LOSS OF DATA, IDENTITY, PRIVACY, OR CONFIDENTIALITY, OR FOR ANY CHARGES OR EXPENSES OF ANY NATURE INCURRED WITHOUT SELLER'S WRITTEN CONSENT, WHETHER BASED IN CONTRACT, TORT OR OTHER LEGAL THEORY. IN NO EVENT SHALL SELLER'S LIABILITY UNDER ANY CLAIM MADE BY BUYER EXCEED THE PURCHASE PRICE PAID FOR THE PRODUCTS.**

**8. Loss to Buyer's Property.** Any designs, tools, patterns, materials, drawings, confidential information or equipment furnished by Buyer or any other items which are or become Buyer's property, will be considered obsolete and maybe destroyed by Seller after two (2) consecutive years have elapsed without Buyer ordering the Products manufactured using such property. Seller shall not be responsible for any loss or damage to such property while it is in Seller's possession or control.

**9. Special Tooling.** Special Tooling includes but is not limited to tooling, jigs, fixtures and associated manufacturing equipment acquired or necessary to manufacture Products. A tooling charge may be imposed for any Special Tooling. Such Special Tooling shall be and remain Seller's property not withstanding payment of any charges by Buyer. In no event will Buyer acquire any interest in Special Tooling belonging to Seller that is utilized in the manufacture of the Products, even if such Special Tooling has been specially converted or adapted for such manufacture and not withstanding any charges paid by Buyer. Unless otherwise agreed, Seller has the right to alter, discard or otherwise dispose of any Special Tooling or other property in its sole discretion at any time.

**10. Security Interest.** To secure payment of all sums due, Seller retains a security interest in all Products delivered to Buyer and, Buyer's acceptance of these Terms is deemed to be a Security Agreement under the Uniform Commercial Code. Buyer authorizes Seller as its attorney to execute and file on Buyer's behalf all documents Seller deems necessary to perfect its security interest.

**11. User Responsibility.** The Buyer through its own analysis and testing, is solely responsible for making the final selection of the Products and assuring that all performance, endurance, maintenance, safety and warning requirements of the application of the Products are met. The Buyer must analyze all aspects of the application and follow applicable industry standards, specifications, and other technical information provided with the Product. If Seller provides Product options based upon data or specifications

 **WARNING:** This product can expose you to chemicals including lead or DEHP which are known to the state of California to cause cancer, birth defects, and other reproductive harm. [www.p65warnings.ca.gov](http://www.p65warnings.ca.gov)



## Offer of Sale (Cont'd)

provided by the Buyer, the Buyer is responsible for determining that such data and specifications are suitable and sufficient for all applications and reasonably foreseeable uses of the Products. In the event the Buyer is not the end-user, Buyer will ensure such end-user complies with this paragraph.

**12. Use of Products, Indemnity by Buyer.** Buyer shall comply with all instructions, guides and specifications provided by Seller with the Products. Unauthorized Uses. If Buyer uses or resells the Products for any uses prohibited in Seller's instructions, guides or specifications, or Buyer otherwise fails to comply with Seller's instructions, guides and specifications, Buyer acknowledges that any such use, resale, or non-compliance is at Buyer's sole risk. Buyer shall indemnify, defend, and hold Seller harmless from any losses, claims, liabilities, damages, lawsuits, judgments and costs (including attorney fees and defense costs), whether for personal injury, property damage, intellectual property infringement or any other claim, brought by or incurred by Buyer, Buyer's employees, or any other person, arising out of: (a) improper selection, application, design, specification or other misuse of Products provided by Seller; (b) any act or omission, negligent or otherwise, of Buyer; (c) Seller's use of patterns, tooling, equipment, plans, drawings, designs or specifications or other information or things furnished by Buyer; (d) damage to the Products from an external cause, repair or attempted repair by anyone other than Seller, failure to follow instructions, guides and specifications provided by Seller, use with goods not provided by Seller, or opening, modifying, deconstructing or tampering with the Products for any reason; or (e) Buyer's failure to comply with these Terms. Seller shall not indemnify Buyer under any circumstance except as otherwise provided in these Terms.

**13. Cancellations and Changes.** Buyer may not cancel or modify any order for any reason, except with Seller's written consent and upon terms that will indemnify, defend and hold Seller harmless against all direct, incidental and consequential loss or damage. Seller, at any time, may change Product features, specifications, designs and availability.

**14. Limitation on Assignment.** Buyer may not assign its rights or obligations without the prior written consent of Seller.

**15. Force Majeure.** Seller does not assume the risk and is not liable for delay or failure to perform any of Seller's obligations by reason of events or circumstances beyond its reasonable control ("Events of Force Majeure"). Events of Force Majeure shall include without limitation: accidents, strikes or labor disputes, acts of any government or government agency, acts of nature, delays or failures in delivery from carriers or suppliers, shortages of materials, or any other cause beyond Seller's reasonable control.

**16. Waiver and Severability.** Failure to enforce any provision of these Terms will not invalidate that provision; nor will any such failure prejudice Seller's right to enforce that provision in the future. Invalidation of any provision of these Terms by legislation or other rule of law shall not invalidate any other provision herein and, the remaining provisions will remain in full force and effect.

**17. Termination.** Seller may terminate any agreement governed by or arising from these Terms for any reason and at anytime by giving Buyer thirty (30) days prior written notice. Seller may immediately terminate, in writing, if Buyer: (a) breaches any provision of these Terms (b) appoints a trustee, receiver or custodian for all or any part of Buyer's property (c) files a petition for relief in bankruptcy on its own behalf, or one if filed by a third party(d) makes an assignment for the benefit of creditors; or (e) dissolves its business or liquidates all or a majority of its assets.

**18. Ownership of Software.** Seller retains ownership of all Software supplied to Buyer hereunder. In no event shall Buyer obtain any greater right in and to the Software than a right in the nature of a license limited to the use thereof and subject to compliance with any other terms provided with the Software.

**19. Indemnity for Infringement of Intellectual Property Rights.** Seller is not liable for infringement of any patents, trademarks, copyrights, trade dress, trade secrets or similar rights ("Intellectual Property Rights") except as provided in this Section. Seller will defend at its expense and will pay the cost of any settlement or damages awarded in an action brought against Buyer based on a third party claim that one or more of the Products sold hereunder

infringes the Intellectual Property Rights of a third party in the country of delivery of the Products by the Seller to the Buyer. Seller's obligation to defend and indemnify Buyer is contingent on Buyer notifying Seller within ten (10) days after Buyer becomes aware of any such claim, and Seller having sole control over the defense of the claim including all negotiations for settlement or compromise. If one or more Products sold hereunder is subject to "such a claim, Seller may, at its sole expense and option, procure for Buyer the right to continue using the Products, replace or modify the Products so as to render them non-infringing, or offer to accept return of the Products and refund the purchase price less a reasonable allowance for depreciation. Seller has no obligation or liability for any claim of infringement: (i) arising from information provided by Buyer; or (ii) directed to any Products provided hereunder for which the designs are specified in whole or part by Buyer; or (iii) resulting from the modification, combination or use in a system of any Products provided hereunder. The foregoing provisions of this Section constitute Seller's sole and exclusive liability and Buyer's sole and exclusive remedy for such claims of infringement of Intellectual Property Rights.

**20. Governing Law.** These Terms and the sale and delivery of all Products are deemed to have taken place in, and shall be governed and construed in accordance with, the laws of the State of Ohio, as applicable to contracts executed and wholly performed therein and without regard to conflicts of laws principles. Buyer irrevocably agrees and consents to the exclusive jurisdiction and venue of the courts of Cuyahoga County, Ohio with respect to any dispute, controversy or claim arising out of or relating to the sale and delivery of the Products.

**21. Entire Agreement.** These Terms, along with the terms set forth in the main body of any Quote, forms the entire agreement between the Buyer and Seller and constitutes the final, complete and exclusive expression of the terms of sale. In the event of a conflict between any term set forth in the main body of a Quote and these Terms, the terms set forth in the main body of the Quote shall prevail. All prior or contemporaneous written or oral agreements or negotiations with respect to the subject matter shall have no effect. These Terms may not be modified unless in writing and signed by an authorized representative of Seller.

**22. Compliance with Laws.** Buyer agrees to comply with all applicable laws, regulations, and industry and professional standards, including those of the United States of America, and the country or countries in which Buyer may operate, including without limitation the U.S. Foreign Corrupt Practices Act ("FCPA"), the U.S. Anti-Kickback Act ("Anti-Kickback Act"), U.S. and E.U. export control and sanctions laws ("Export Laws"), the U.S. Food Drug and Cosmetic Act ("FDCA"), and the rules and regulations promulgated by the U.S. Food and Drug Administration ("FDA"), each as currently amended. Buyer agrees to indemnify, defend, and hold harmless Seller from the consequences of any violation of such laws, regulations and standards by Buyer, its employees or agents. Buyer acknowledges that it is familiar with all applicable provisions of the FCPA, the Anti-Kickback Act, Export Laws, the FDCA and the FDA and certifies that Buyer will adhere to the requirements thereof and not take any action that would make Seller violate such requirements. Buyer represents and agrees that Buyer will not make any payment or give anything of value, directly or indirectly, to any governmental official, foreign political party or official thereof, candidate for foreign political office, or commercial entity or person, for any improper purpose, including the purpose of influencing such person to purchase Products or otherwise benefit the business of Seller. Buyer further represents and agrees that it will not receive, use, service, transfer or ship any Product from Seller in a manner or for a purpose that violates Export Laws or would cause Seller to be in violation of Export Laws."

05/17

 **WARNING:** This product can expose you to chemicals including lead or DEHP which are known to the state of California to cause cancer, birth defects, and other reproductive harm. [www.p65warnings.ca.gov](http://www.p65warnings.ca.gov)





Parker Hannifin Corporation  
**Pump & Motor Division**  
101 Canterbury Road  
Kings Mountain, NC 28086  
Phone: (704) 730-2000  
Fax: (704) 730-7411  
[www.parker.com/pmd](http://www.parker.com/pmd)  
[www.phtruck.com](http://www.phtruck.com)

Your Local Authorized Parker Distributor