

Parker D101VA Series Air Operated, Directional Control Valve Service Manual

A

Series D101VA directional control valves are 5-chamber, air pilot operated valves. They are available in 2 or 3-position styles. These valves are manifold or subplate mounted, and conform to NFPA's D10, CETOP 10 mounting pattern.

Specifications

Mounting Pattern	NFPA D10, CETOP 10, NG32
Max. Operating Pressure	207 Bar (3000 PSI)
Max. Tank Pressure	Internal Drain Model: 34 Bar (500 PSI) External Drain Model: 207 Bar (3000 PSI)
Max. Drain Pressure	34 Bar (500 PSI)
Maximum Flow	See Reference Chart
Pilot Pressure	Air Min 3.4 Bar (50 PSI) Air Max 10.2 Bar (150 PSI)
Response Time	Varies with pilot line size and length, pilot pressure, pilot valve shift time & flow capacity (GPM)

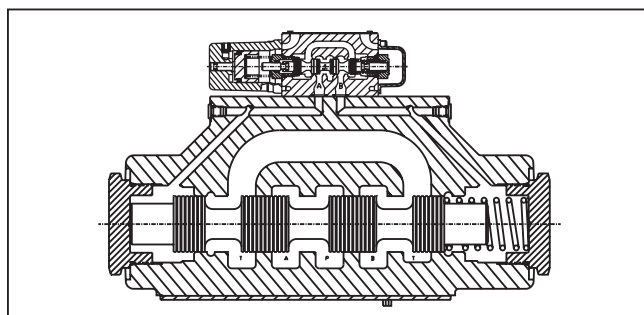
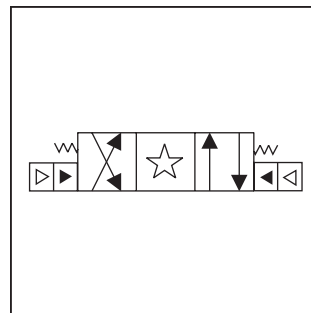
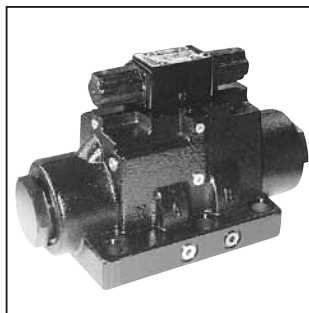

Features

- Low pressure drop design.
- Hardened spools provide long life.

Ordering Information

D

Directional Control Valve

101V

Basic Valve

NFPA D10
CETOP 10

A

Air Operated Pilot

□

Spool

□

Style

□

Pilot Supply and Drain

□

Seal

Code	Type
N	Nitrile
V	Fluorocarbon

□

Valve Variations

Code	Description
7	Pilot Choke – Meter Out
8	Stroke Adj. 'B' End
9	Stroke Adj. 'A' End
60	Pilot Choke – Meter In
89	Stroke Adj. 'A' & 'B' Ends
90	1/4 BSPP Threads

□

Design Series

NOTE:
Not required when ordering.

Valve schematic symbols are per NFPA/ANSI standards, providing flow P to A when energizing operator A. Note operators reverse sides on #8 and #9 spools. See installation information for details.

Code	Symbol
1	
2	
4	
8*	
9**	
11	

* 8 spool has closed crossover.
** 9 spool has open crossover.

Code	Description
1	Int. pilot/Ext. drain
2	Ext. pilot/Ext. drain
4#	Int. pilot/Int. drain
5	Ext. pilot/Int. drain

Not available with 2, 8 & 9 spools.

Code	Description	Symbol
B†	Sgl. operator, 2 position, spring offset. P to A and B to T in offset position.	
C	Dbl. operator, 3 position, spring centered.	
H†	Sgl. operator, 2 position, spring offset. P to B and A to T in offset position.	

† Available with 1, 2, 4 & 11 spools only.

This condition varies with spool code.

Valve Weight: 35.3 kg (77.8 lbs.)
Standard Bolt Kit: BK229
Metric Bolt Kit: BKM229

Bold: Designates Tier I products and options.

Non-Bold: Designates Tier II products and options. These products will have longer lead times.

Inch equivalents for millimeter dimensions are shown in (**)

A

Air Operated

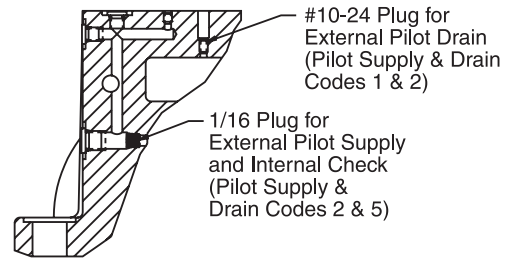
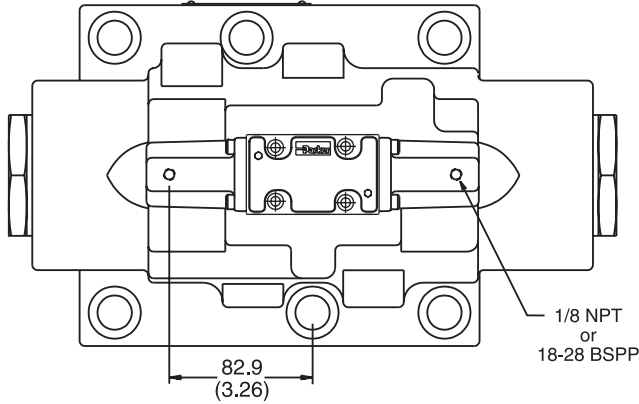

Section A-A

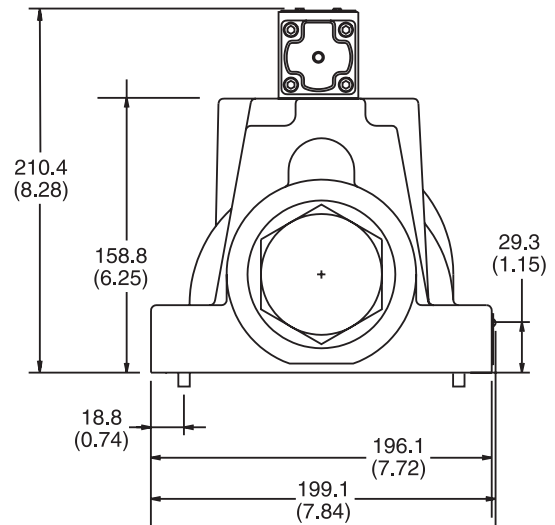
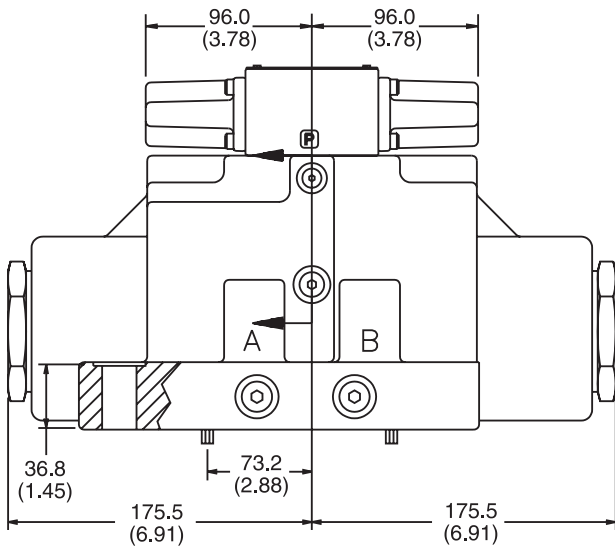

Note: 36.83mm (1.45") from bottom of bolt hole counterbore to bottom of valve.