

Parker D81VA Series Air Operated Directional Control Valve Service Manual

General Description

Series D81VA directional control valves are 5-chamber, air pilot operated valves. They are available in 2 or 3-position styles. These valves are manifold or subplate mounted, and conform to NFPA's D08, CETOP 8 mounting pattern.

Specifications

Mounting Pattern	NFPA D08 , CETOP 8, NG25
Max. Operating Pressure	345 Bar (5000 PSI)
Max. Tank Line Pressure	Internal Drain Model: 34 Bar (500 PSI) External Drain Model: 207 Bar (3000 PSI)
Max. Drain Pressure	34 Bar (500 PSI)
Maximum Flow	See Switching Limit Charts
Pilot Pressure	Air Min 3.4 Bar (50 PSI) Air Max 10.2 Bar (150 PSI)
Response Time	Varies with pilot line size and length, pilot pressure, pilot valve shift time & flow capacity (GPM)

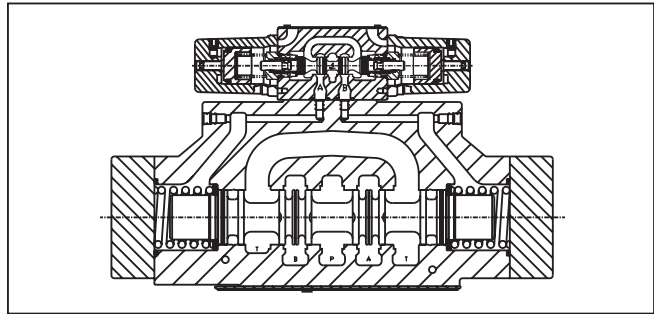
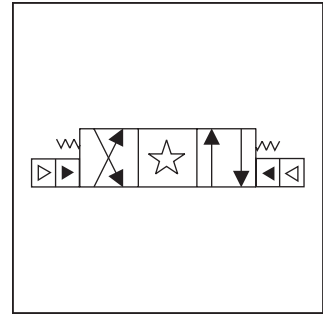
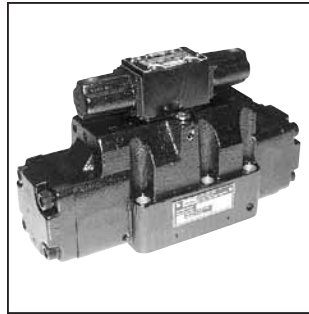

Features

- Low pressure drop design.
- Fast response option available.
- Hardened spools provide long life.

Ordering Information

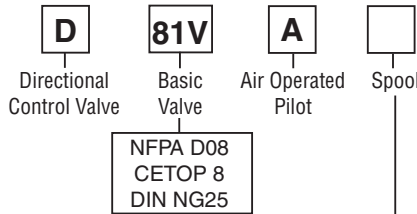

Code	Symbol	Code	Symbol
001		011	
002		012	
004		020*	
009**		030**	

* 020 spool has closed crossover.
** 009 & 030 spools have open crossover.

Valve schematic symbols are per NFPA/ANSI standards, providing flow P to A when energizing operator A. Note operators reverse sides for #9 spool. See installation information for details.

Valve Weight: Single Operated
19.9 kg (43.9 lbs.)

Standard Bolt Kit: BK228

Metric Bolt Kit: BKM228

Code	Description
1	Int. pilot/Ext. drain
2	Ext. pilot/Ext. drain
4#	Int. pilot/Int. drain
5	Ext. pilot/Int. drain

Not available with 002, 008, 009 & 030 spools.

Code	Description
Omit	Standard
7	Pilot Choke – Meter Out
8	Stroke Adj. 'B' End
9	Stroke Adj. 'A' End
60	Pilot Choke – Meter In
89	Stroke Adj. 'A' & 'B' Ends
90	1/4 BSPP Threads

Design Series
NOTE:
Not required when ordering.

Code	Description	Symbol
B†	Sgl. operator, 2 position, spring offset. P to A and B to T in offset position.	
C	Dbl. operator, 3 position, spring centered.	
D†	Dbl. operator, 2 position, detent.	
E	Sgl. operator, 2 position, spring centered. P to B and A to T when energized.	
H†	Sgl. operator, 2 position, spring offset. P to B and A to T in offset position.	
K	Sgl. operator, 2 position. Spring centered. P to A and B to T when energized.	

† Available with 020 & 030 spools only.

This condition varies with spool code.

Bold: Designates Tier I products and options.

Non-bold: Designates Tier II products and options. These products will have longer lead times.

D81.indd, dd



Inch equivalents for millimeter dimensions are shown in (**)

A

Air Operated

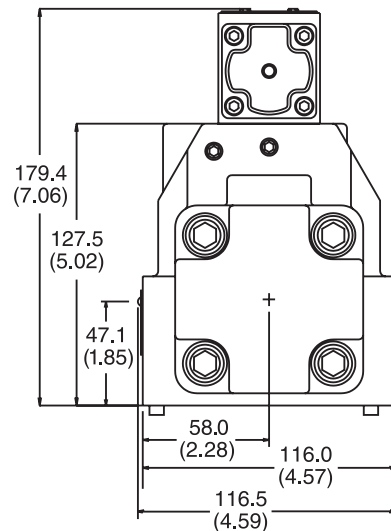
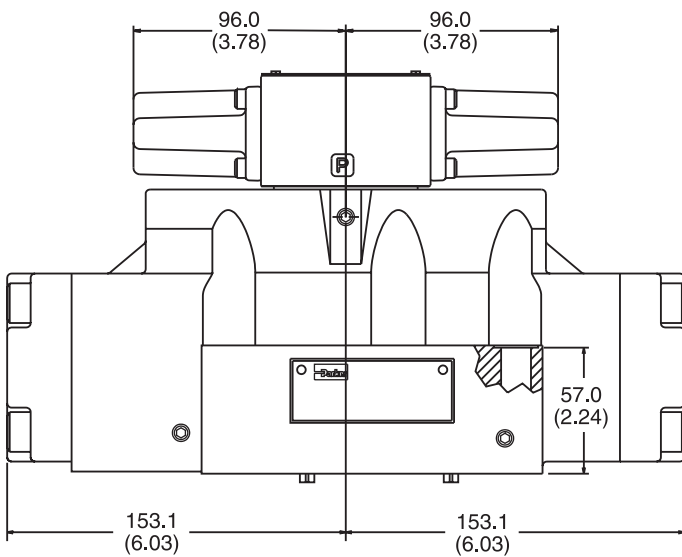
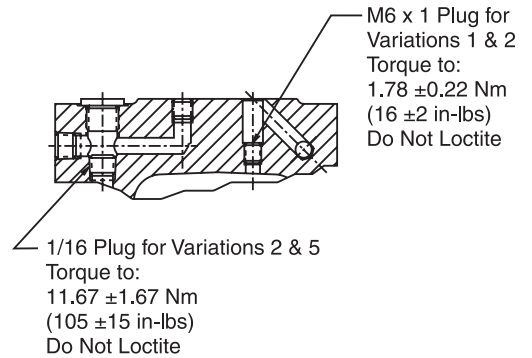
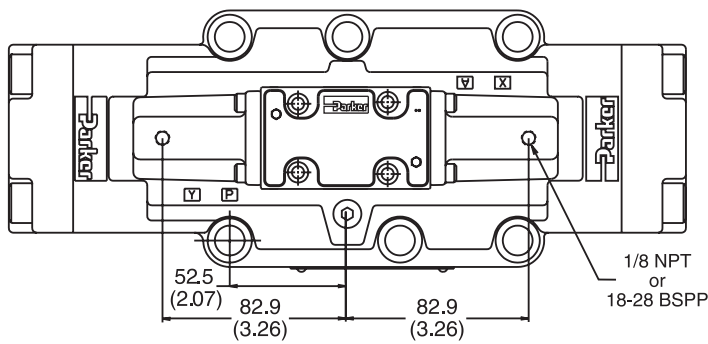

Note: 57mm (2.24") from bottom of bolt hole counterbore to bottom of valve.