

General Description

Series F flow control valves provide precise control of flow and shut-off in one direction, and automatically permit full flow in the opposite direction.

Operation

A two-step needle allows fine adjustment at low flow by using the first three turns of the adjusting knob. The next three turns open the valve to full flow, and also provide standard throttling adjustments.

Features

- The exclusive “Colorflow” color-band reference scale on the valve stem is a great convenience and time-saver in setting the valve originally and in returning it to any previous setting.
- A simple set screw locks the valve on any desired setting.
- A tamperproof option (T) feature is also available to prevent accidental or intentional adjustment of flow setting.

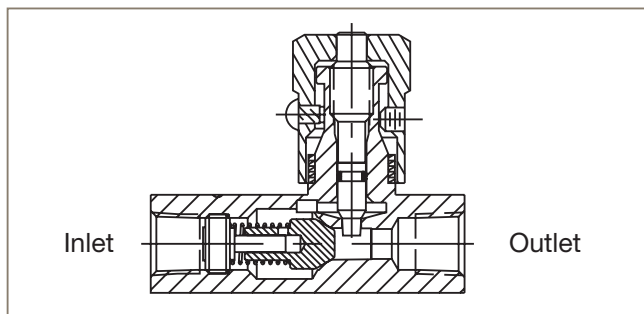
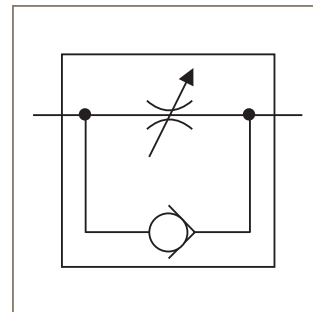

Specifications

Maximum Operating Pressure	Brass: 140 Bar (2000 PSI); except for F1600 brass which is 35 Bar (500 PSI) Steel & Stainless Steel: 350 Bar (5000 PSI) for 200 thru 800 & 420 thru 1220; Stainless Steel: 210 Bar (3000 PSI) for 1200 thru 3200 & 1600 thru 3220
Material	Body: Steel, Brass, or 303 Stainless Steel Knob: Steel - Zinc plated Spring: 302 Stainless Steel Poppet: 416 Stainless Steel Retainer: 416 Stainless Steel Needle: 416 Stainless Steel
Poppets	Soft seal poppet in brass 200 - 820 sizes Solid metal 416 stainless steel poppet on all other sizes and styles
Nominal Cracking Pressure	0.4 Bar (5 PSI) standard
Temperature Range of Seal Compound	-40°C to +121°C (-40°F to +250°F) Nitrile (standard) -26°C to +205°C (-15°F to +400°F) Fluorocarbon

WARNING: This product can expose you to chemicals including Lead, Nickel (Metallic), or 1,3-Butadiene which are known to the State of California to cause cancer, and Lead or 1,3-Butadiene which is known to the State of California to cause birth defects and other reproductive harm. For more information go to www.P65Warnings.ca.gov.

Cat3300.indd, ddp, 09/22

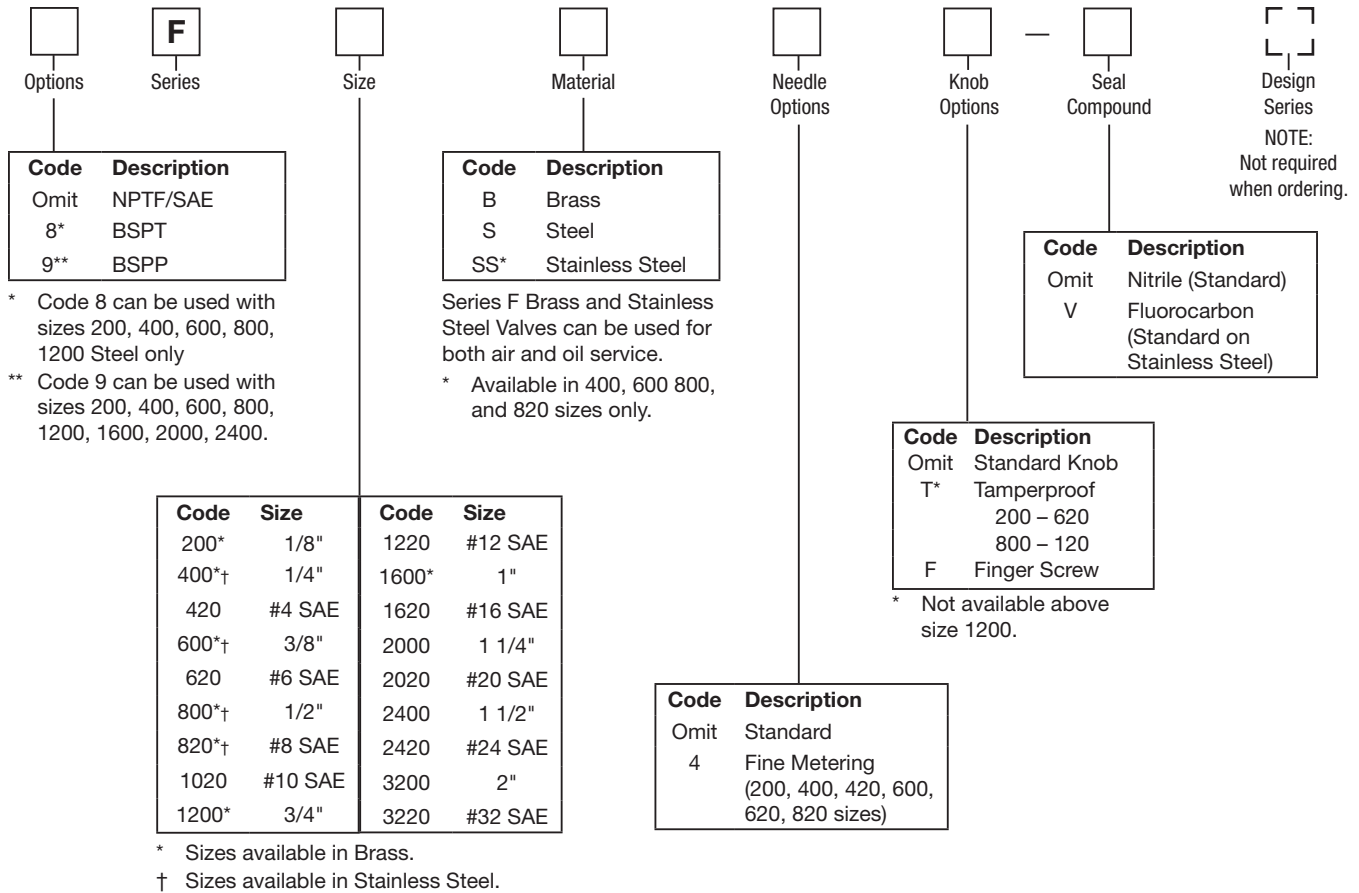

Model Number	Free Flow Rate, Max. LPM (GPM)	Free Flow Orifice Area in. ²	Free Flow C _v	Effective Orifice Area in. ²	Effective Control Flow C _v	Model Number	Effective Orifice Area in. ²	Effective Control Flow C _v
F200	11 (3)	0.023	0.53	0.0102	0.230	F400-4	0.0044	0.0758
F420	11 (3)	0.023	0.53	0.0102	0.230	F600-4	0.0097	0.1530
F400	19 (5)	0.068	1.56	0.0194	0.433	F620-4	0.0044	0.0758
F620	19 (5)	0.068	1.56	0.0194	0.433	F820-4	0.0097	0.1530
F600	30 (8)	0.099	2.27	0.0344	0.787			
F820	30 (8)	0.099	2.27	0.0344	0.787			
F800	57 (15)	0.224	5.11	0.0427	0.976			
F1020	57 (15)	0.224	5.11	0.0427	0.976			
F1200	95 (25)	0.348	7.95	0.1080	2.470			
F1220	95 (25)	0.348	7.95	0.1080	2.470			
F1600	151 (40)	0.453	10.35	0.2300	5.250			
F1620	151 (40)	0.453	10.35	0.3070	7.000			
F2000	265 (70)	0.855	19.52	0.2300	5.250			
F2020	265 (70)	0.855	19.52	0.3710	8.470			
F2400	379 (100)	0.955	21.82	0.2300	5.250			
F2420	379 (100)	0.955	21.82	0.3710	8.470			
F3200	568 (150)	1.046	23.90	0.2300	5.250			
F3220	568 (150)	1.046	23.90	0.6010	13.410			

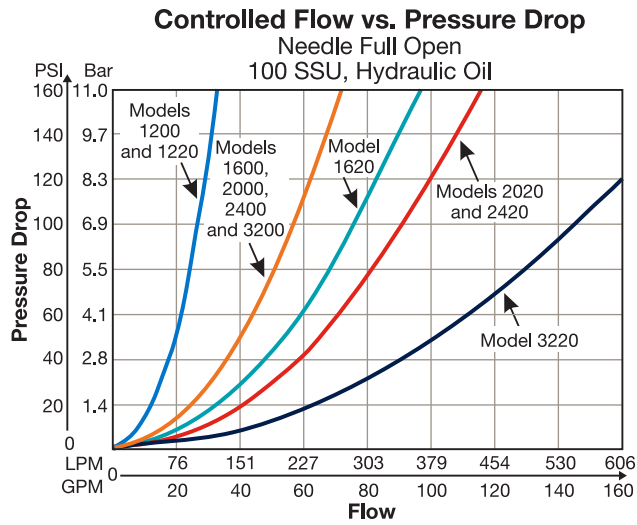
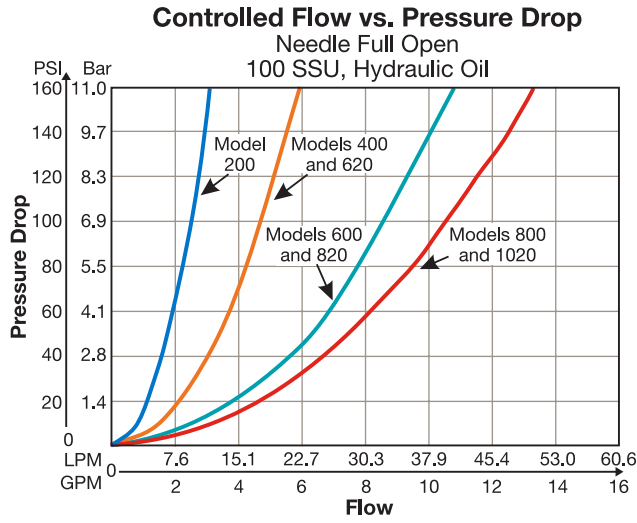

Inch equivalents for millimeter dimensions are shown in (**)

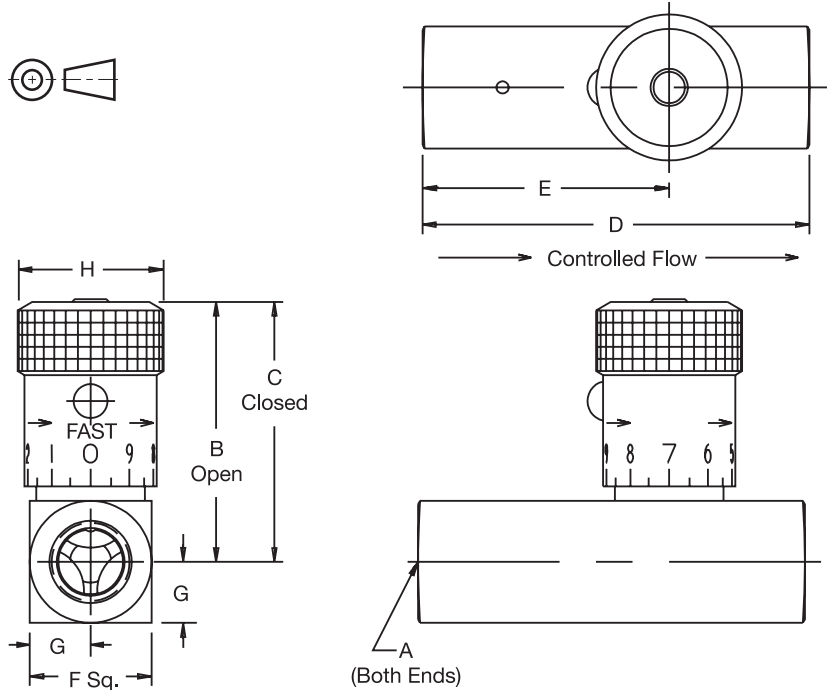

Knob Options

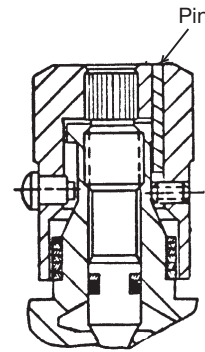

Tamperproof Option (Code "T") permanently locks knob at desired flow setting by installing a pin in predrilled hole.

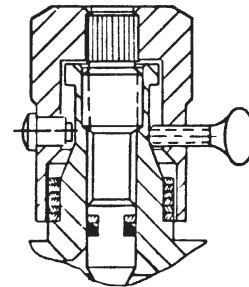

Finger screw Option (Code "F") provides this thumb-screw in place of set screw.

Model Number	Weight kg (lbs)	A	B	C	D	E	F	G	H
F200	0.1 (0.3)	1/8-27 NPTF	39.1 (1.54)	35.3 (1.39)	50.8 (2.00)	32.5 (1.28)	16.0 (0.63)	7.9 (0.31)	19.1 (0.75)
F400	0.2 (0.5)	1/4-18 NPTF	45.5 (1.79)	40.4 (1.59)	66.8 (2.63)	42.2 (1.66)	20.6 (0.81)	10.4 (0.41)	20.6 (0.81)
F420	0.2 (0.5)	7/16-20 UNF #4 SAE	41.4 (1.63)	37.6 (1.48)	68.3 (2.69)	42.9 (1.69)	20.6 (0.81)	10.4 (0.41)	19.1 (0.75)
F600	0.3 (0.7)	3/8-18 NPTF	55.4 (2.18)	49.5 (1.95)	69.9 (2.75)	44.5 (1.75)	25.4 (1.00)	12.7 (0.50)	25.4 (1.00)
F620	0.3 (0.7)	9/16-18 UNF #6 SAE	47.7 (1.88)	42.7 (1.68)	79.2 (3.12)	48.8 (1.92)	25.4 (1.00)	12.7 (0.50)	20.6 (0.81)
F800	0.7 (1.5)	1/2-14 NPTF	68.6 (2.70)	61.5 (2.42)	87.4 (3.44)	56.6 (2.23)	31.8 (1.25)	16.0 (0.63)	30.2 (1.19)
F820	0.5 (1.1)	3/4-16 UNF #8 SAE	56.9 (2.24)	51.1 (2.01)	88.9 (3.50)	53.8 (2.12)	28.4 (1.12)	14.2 (0.56)	25.4 (1.00)
F1020	0.8 (1.8)	7/8-14 UNF #10 SAE	68.6 (2.70)	61.5 (2.42)	101.6 (4.00)	65.0 (2.56)	31.8 (1.25)	15.7 (0.62)	30.2 (1.19)
F1200	1.2 (2.6)	3/4-14 NPTF	85.9 (3.38)	71.4 (2.81)	98.6 (3.88)	65.5 (2.58)	38.1 (1.50)	19.1 (0.75)	35.1 (1.38)
F1220	1.2 (2.6)	1 1/6-12 UN #12 SAE	85.9 (3.38)	71.4 (2.81)	117.3 (4.62)	76.5 (3.01)	38.1 (1.50)	19.1 (0.75)	35.1 (1.38)
F1600	2.3 (5.1)	1-11 1/2 NPTF	123.7 (4.87)	106.9 (4.21)	127.0 (5.00)	81.8 (3.22)	44.5 (1.75)	22.4 (0.88)	47.8 (1.88)*
F1620	2.3 (5.1)	1 5/16-12 UN #16 SAE	130.8 (5.15)	114.0 (4.49)	142.7 (5.62)	88.9 (3.50)	57.2 (2.25)	28.4 (1.12)	47.8 (1.88)*
F2000	3.7 (8.2)	1 1/4-11 1/2 NPTF	130.0 (5.12)	113.3 (4.46)	143.0 (5.63)	98.6 (3.88)	57.2 (2.25)	28.7 (1.13)	47.8 (1.88)*
F2020	3.7 (8.2)	1 5/8-12 UN #20 SAE	140.2 (5.52)	123.4 (4.86)	165.1 (6.50)	108.0 (4.25)	69.9 (2.75)	35.1 (1.38)	47.8 (1.88)*
F2400	4.6 (10.2)	1 1/2-11 1/2 NPTF	136.4 (5.37)	119.6 (4.71)	143.0 (5.63)	113.5 (4.47)	69.9 (2.75)	35.1 (1.38)	47.8 (1.88)*
F2420	4.6 (10.2)	1 7/8-12 UN-2B #24 SAE	143.5 (5.65)	126.7 (4.99)	184.2 (7.25)	127.0 (5.00)	76.2 (3.00)	38.1 (1.50)	47.8 (1.88)*
F3200	7.9 (17.4)	2-11 1/2 NPTF	146.1 (5.75)	129.3 (5.09)	165.1 (6.50)	134.9 (5.31)	88.9 (3.50)	44.5 (1.75)	47.8 (1.88)*
F3220	7.9 (17.4)	2 1/2-12 UN #32 SAE	163.6 (6.44)	139.4 (5.49)	228.6 (9.00)	155.7 (6.13)	101.6 (4.00)	50.8 (2.00)	47.8 (1.88)*

* = Hex