

Parker SE05SE10SE15 & SE2N Series Two-stage, 4-way, Flapper and Nozzle Servovalve Service Manual

General Description

Series SE05, SE10 and SE15 are two stage, 4-way, flapper and nozzle style servovalves. These valves have high performance spool and sleeve designs. A special jewel feedback design enhances durability and prevents ball glitch problems, which can occur in other types of servovalves. These valves are rated for 315 Bar (4500 PSI) service. **Features**

- Lapped spool and sleeve
- Jewel feedback ball for durability
- Aluminum body
- Medium and High performance
- SE05 15.88 mm (0.625 in.) port circle
- SE10 19.81 mm (0.780 in.) port circle
- SE15 23.80 mm (0.937 in.) port circle

Specifications

Flow Rating ±10% @ 70 Bar (1000 PSI)	4, 10, 20, 40, 60 LPM (1.0, 2.5, 5, 10, 15 GPM)
Supply Pressure	10 – 315 Bar (145 – 4500 PSI)
Tank Port Pressure	210 Bar (3000 PSI) Max. < 10 Bar (145 PSI) for best performance
Null Leakage Flow per 70 Bar (1000 PSI)	0.6 – 1.0 LPM (0.16 – 0.26 GPM)
Pilot Flow @ 210 Bar (3000 PSI)	0.4 – 0.7 LPM (0.1 – 0.2 GPM)
Input Command @ 210 Bar (3000 PSI)	±40 mA std.
Frequency Response @ 90° phase shift	> 100 Hz (See Performance Curves)
Non-Linearity	≤ 10%
Hysteresis	≤ 3%
Threshold	≤ 0.5%
Null Shift with temperature with pressure	≤ 2% per 55°C (100°F) ≤ 2% per 70 Bar (1000 PSI)
Pressure Gain change in pressure per 1% change in input command	60% typical
Step Response	10 – 100%, < 6 ms
Fluid	Petroleum based Mineral Oil, 10 – 110 cSt at 38°C (100°F)
Fluid Cleanliness	ISO 4406 15/12 or better
Operating Temperature	-30°C to +130°C (-22°F to +266°F)
Protection Class	NEMA 4, IP65

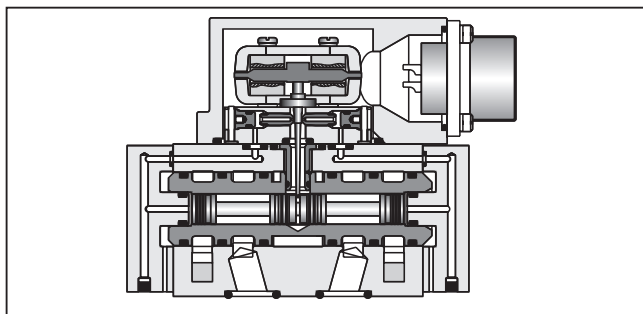
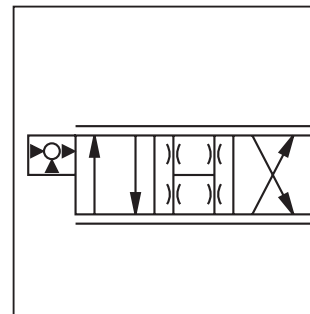

C

Flow vs. Pressure Drop

at 100% command
Flow Path: P→C1→C2→R

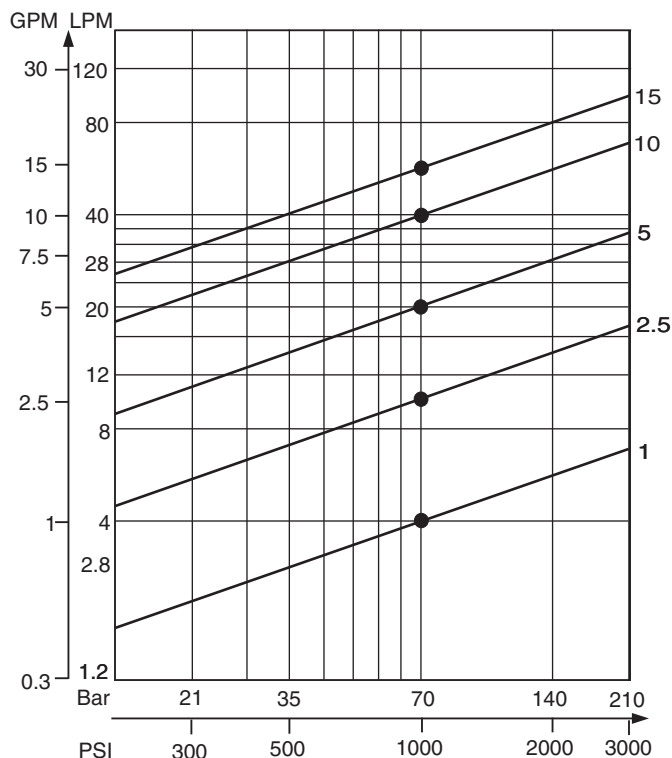

WARNING: This product can expose you to chemicals including Lead, Nickel (Metallic), or 1,3-Butadiene which are known to the State of California to cause cancer, and Lead or 1,3-Butadiene which is known to the State of California to cause birth defects and other reproductive harm. For more information go to www.P65Warnings.ca.gov.

C01_Cat2550.indd, ddp, 04/19



Ordering Information

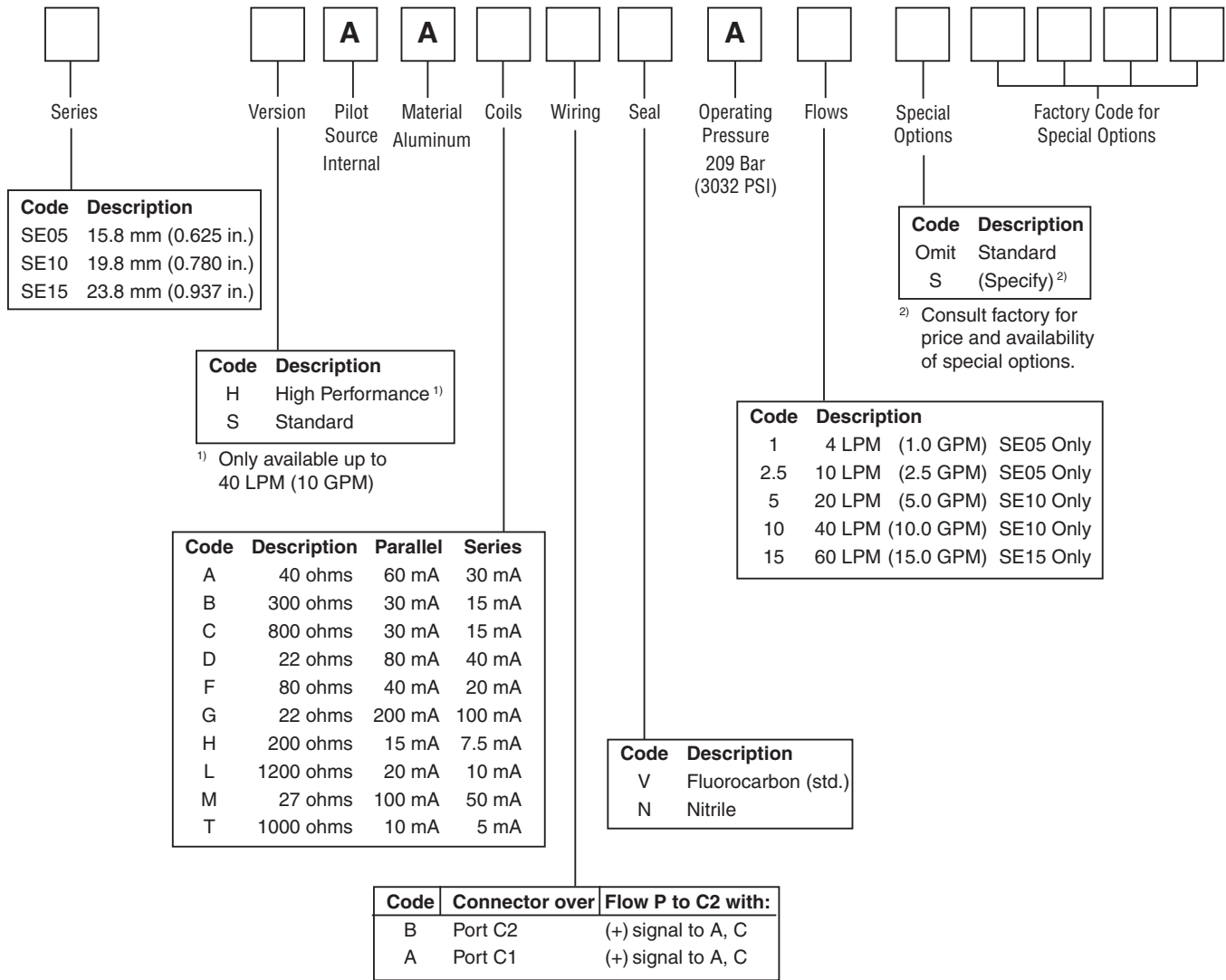

Weight: 1.0 kg (2.2 lbs.)
Cable with mating connector: EHC154S
Mating connector: MS3106E-14S-2S
Electronics: BD101, 23-5030, 23-7030, PMC10, BD90, or BD95

SE05
Bolt kit: 4 of M5 x 60 mm, or 4 of #10-32x2.25"
Flushing valve: 11-0500
Metric Subplate: DS02SPS8M (M18x1.5 ISO 6149 side ports)
SAE Subplate: DS02SPS8S (#8 SAE side ports)

SE10
Bolt kit: 4 of M5 x 60 mm, or 4 of #10-32x2.25"
Flushing valve: 11-0500
Metric Subplate: DS71SPS8M (M18x1.5 ISO 6149 side ports)
SAE Subplate: DS71SPS8S (#8 SAE side ports)

SE15
Bolt kit: 4 of M6 x 60 mm, or 4 of 1/4-20x2.25"
Flushing valve: 11-0500
Metric Subplate: DS72SPS8M (M18x1.5 ISO 6149 side ports)
SAE Subplate: DS72SPS8S (#8 SAE side ports)

Performance Curves

Frequency Response at 210 Bar (3000 PSI)

Standard Response

SE05: 4 – 20 LPM (1 – 5 GPM)

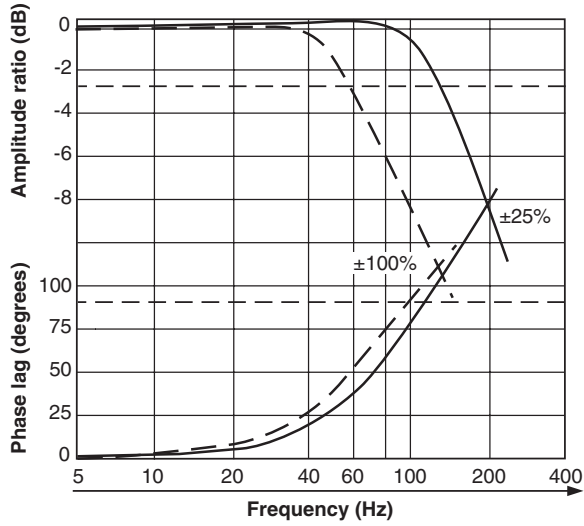

High Response

SE05: 4 – 20 LPM (1 – 5 GPM)

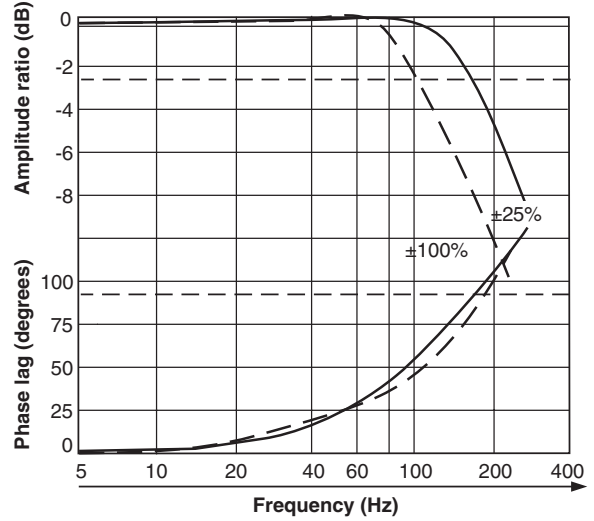

Standard Response

SE10: 40 LPM (10 GPM)

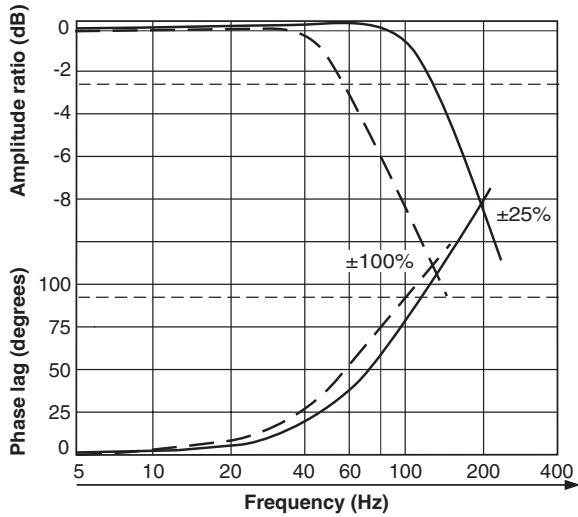

High Response

SE10: 40 LPM (10 GPM)

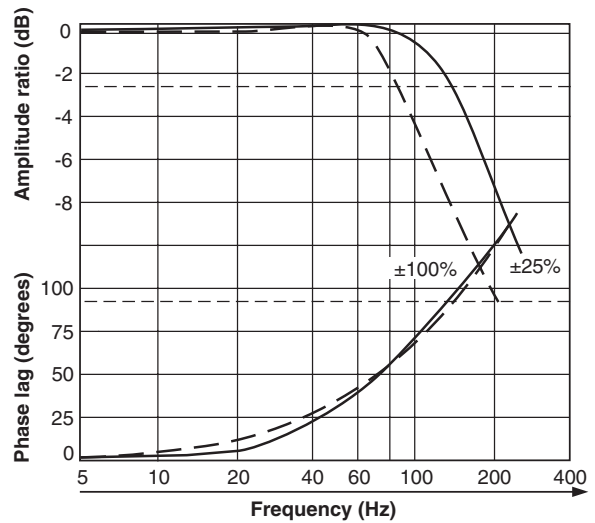

Standard Response

SE15: 60 LPM (15 GPM)

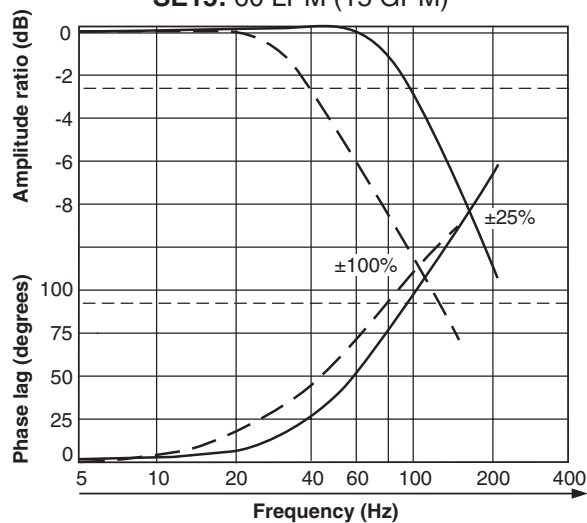

Performance Curves

Step Response at 210 Bar (3000 PSI)

Standard Response

SE05, SE10 & SE15: 4 – 40 LPM (1 – 10 GPM)

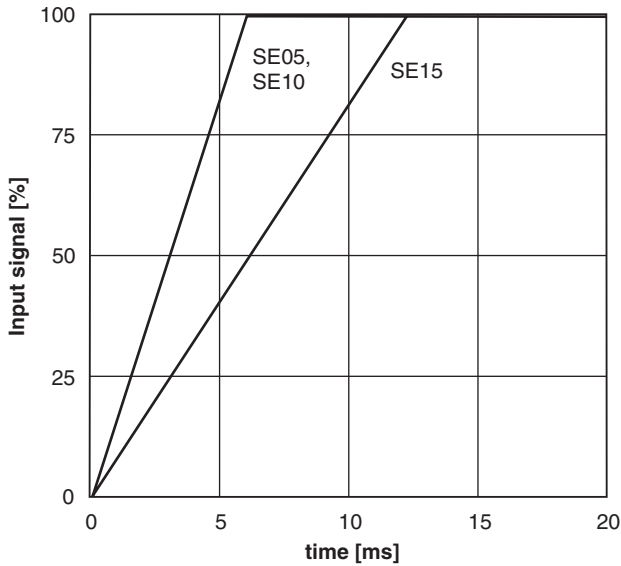

High Response

SE05, SE10 & SE15: 4 – 40 LPM (1 – 10 GPM)

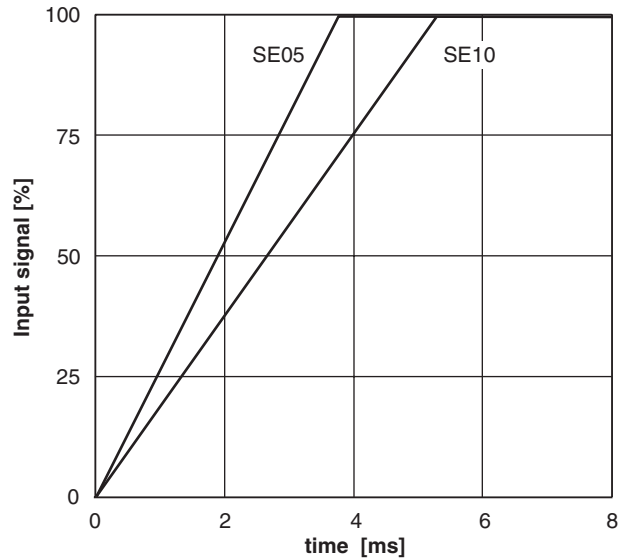

C

Installation Wiring Options

This servovalve has two coils. When connecting the valve to a drive amplifier, the user's external wiring may put the coils either in parallel or in series as needed. Refer to the illustrations below and to the mounting pattern for this valve to insure proper control phasing.

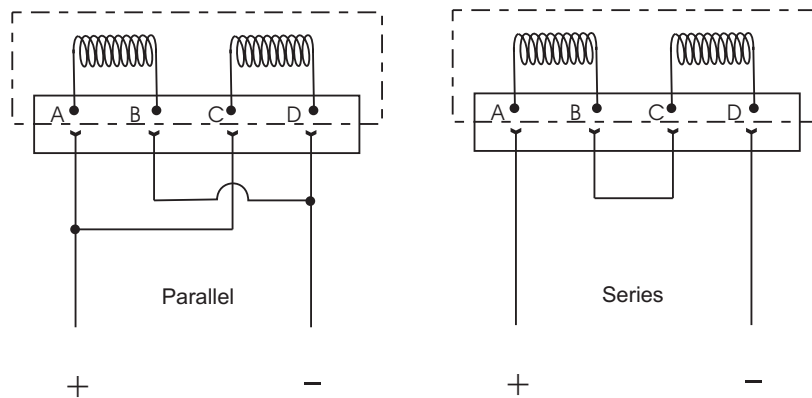

Polarity shown connects flow from P to C2 port.

Dimensions

Inch equivalents for millimeter dimensions are shown in (**)

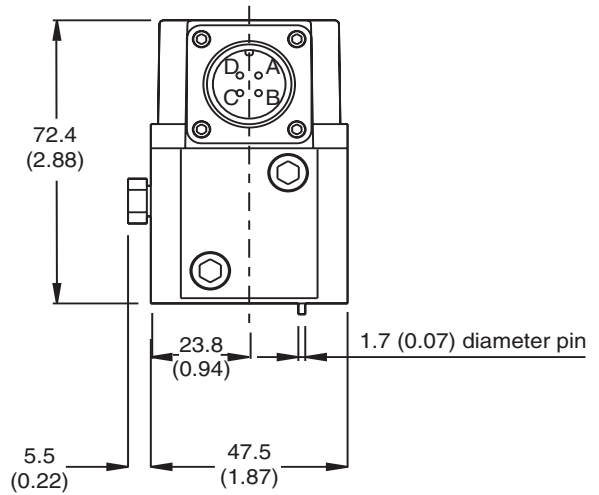
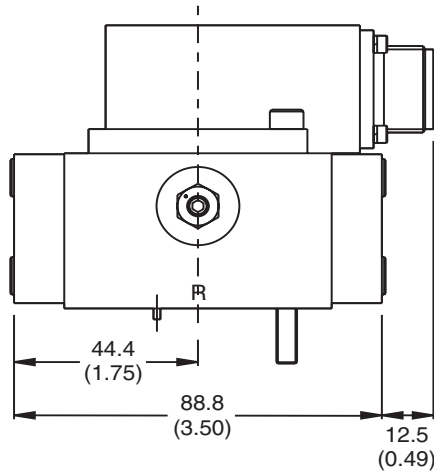

SE05

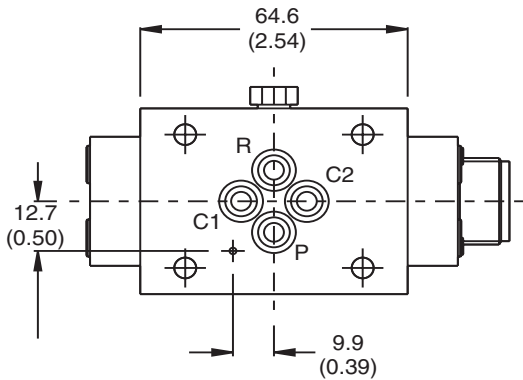

SE10

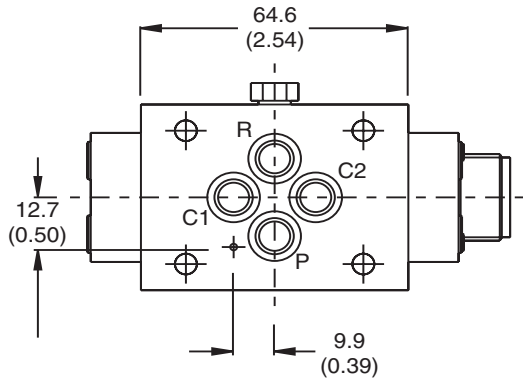

SE15

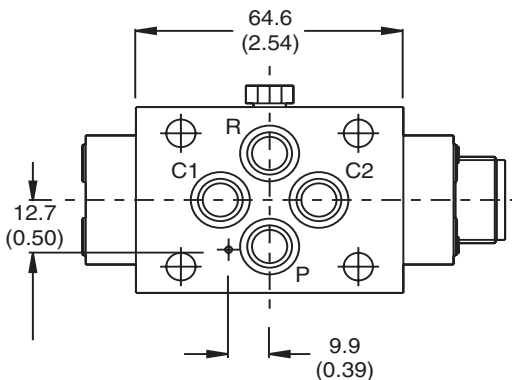

1. Suggested mounting bolts: For SE05 and SE10 use M5 x 60 mm or #10-32 x 2.25" long high tensile steel, socket-head cap screws. For SE15 use M6 x 60 mm or 1/4-20 x 2.25" long high tensile steel, socket-head cap screws.
2. 4-way electrical connector mates with MS3106E-14S-2S or equivalent. Is available at 180° to position shown (advise desired position at time of order).
3. Base O-Rings:
SE05 use Parker 2011V-9 (7.66 mm I/D x 1.78 section)
SE10 use Parker 2012V-9 (9.25 mm I/D x 1.78 section)
SE15 use Parker 2013V-9 (10.82 mm I/D x 1.78 section)
4. Null adjust requires 10 A/F ring spanner (10 mm box end wrench) and 2.5 hexagon key. Flow out of C1 will increase with clockwise rotation of key.
5. See mounting dimensions for port size and locations.

Dimensions

SE05 Mounting Surface

1. The recommended full-thread depth is 16 mm (0.630 in.).
2. The minimum depth of hole G is 4 mm (0.157 in.).
3. Surface roughness $R_a < 0.8 \mu\text{m}$ [N6], as specified in ISO 468 and ISO 1302.
4. Surface flatness: 0.025 mm (0.001) as specified in ISO 1101.

15.88 (0.625) port circle

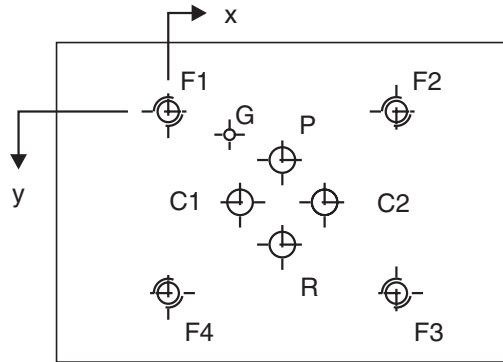

SE10 Mounting Surface

1. The recommended full-thread depth is 16 mm (0.630 in.).
2. The minimum depth of hole G is 4 mm (0.157 in.).
3. Surface roughness $R_a < 0.8 \mu\text{m}$ [N6], as specified in ISO 468 and ISO 1302.
4. Surface flatness: 0.025 mm (0.001) as specified in ISO 1101.

19.81 (0.780) port circle

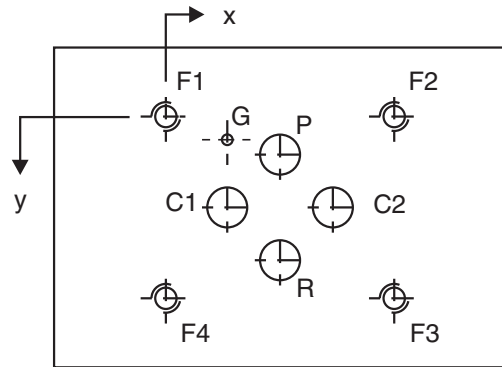

SE15 Mounting Surface

1. The recommended full-thread depth is 18 mm (0.709 in.).
2. The minimum depth of hole G is 4 mm (0.157 in.).
3. Surface roughness $R_a < 0.8 \mu\text{m}$ [N6], as specified in ISO 468 and ISO 1302.
4. Surface flatness: 0.025 mm (0.001 in.) as specified in ISO 1101.

23.80 (0.937) port circle

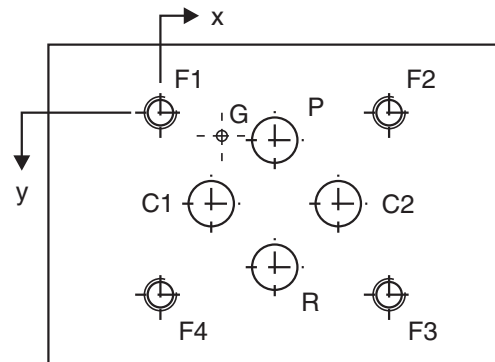

Dimensions

SE05

Metric Dimensions (mm)									
(± 0.1 mm)									
Axis	P	C1	R	C2	G	F1	F2	F3	F4
		Ø 5 max	Ø 5 max	Ø 5 max	Ø 5 max	Ø 3.5	M5	M5	M5
x	21.4	13.5	21.4	29.3	11.5	0	42.8	42.8	0
y	9.2	17.1	25.0	17.1	4.4	0	0	34.2	34.2

U.S. Dimensions (inches)									
(± 0.004 in.)									
Axis	P	C1	R	C2	G	F1	F2	F3	F4
		Ø 0.195 max	Ø 0.195 max	Ø 0.195 max	Ø 0.195 max	Ø 0.136	# 10 -32	# 10 -32	# 10 -32
x	0.843	0.531	0.843	1.153	0.453	0	1.685	1.685	0
y	0.362	0.673	0.984	0.673	0.173	0	0	1.347	1.347

SE10

Metric Dimensions (mm)									
(± 0.1 mm)									
Axis	P	C1	R	C2	G	F1	F2	F3	F4
		Ø 7.5 max	Ø 7.5 max	Ø 7.5 max	Ø 7.5 max	Ø 3.5	M5	M5	M5
x	21.4	11.5	21.4	31.3	11.5	0	42.8	42.8	0
y	7.2	17.1	27.0	17.1	4.4	0	0	34.2	34.2

U.S. Dimensions (inches)									
(± 0.004 in.)									
Axis	P	C1	R	C2	G	F1	F2	F3	F4
		Ø 0.290 max	Ø 0.290 max	Ø 0.290 max	Ø 0.195 max	Ø 0.14	# 10 -32	# 10 -32	# 10 -32
x	0.843	0.453	0.843	1.232	0.453	0	1.685	1.685	0
y	0.283	0.673	1.063	0.673	0.173	0	0	1.347	1.347

SE15

Metric Dimensions (mm)									
(± 0.1 mm)									
Axis	P	C1	R	C2	G	F1	F2	F3	F4
		Ø 8 max	Ø 8 max	Ø 8 max	Ø 8 max	Ø 3.5	M6	M6	M6
x	21.4	9.5	21.4	33.3	11.5	0	42.8	42.8	0
y	5.1	17.1	29.0	17.1	4.4	0	0	34.2	34.2

U.S. Dimensions (inches)									
(± 0.004 in.)									
Axis	P	C1	R	C2	G	F1	F2	F3	F4
		Ø 0.312 max	Ø 0.312 max	Ø 0.312 max	Ø 0.312 max	Ø 0.14	1/4 - 20	1/4 - 20	1/4 - 20
x	0.843	0.374	0.843	1.311	0.453	0	1.685	1.685	0
y	0.201	0.673	1.142	0.673	0.173	0	0	1.347	1.347