

Parker Series C4V Direct Operated / Hydraulically Pilot Operated Check Valve Service Manual

Direct operated check valves C4V allow free flow from A to B. The counter direction is blocked. The C4V series is equipped with a leak-free seat type cartridge.

Function

The pressure arising in port A lifts the poppet from the valve seat and releases the flow to B. In the counter direction, the spring and the pressure on top of the cartridge hold the poppet onto the seat and block the flow.



C4V06

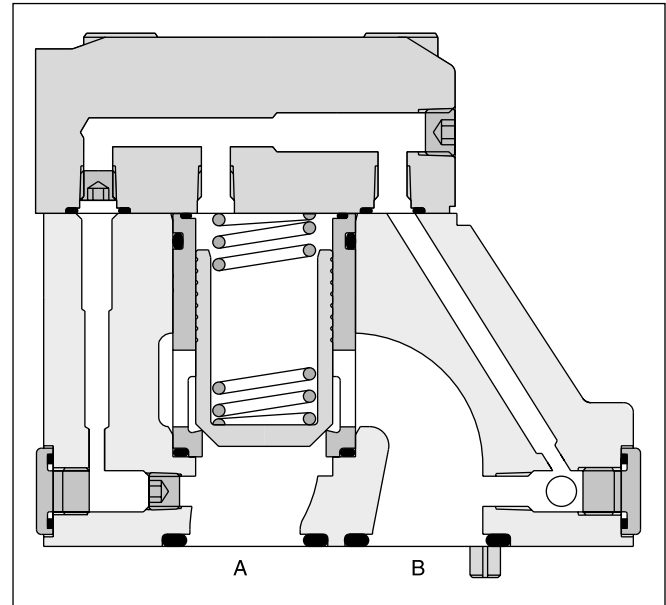
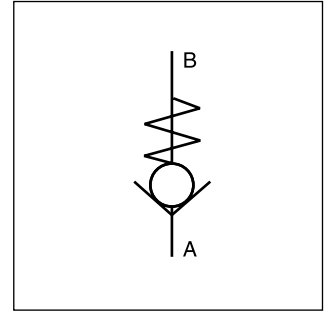

C4V10

6

Ordering code

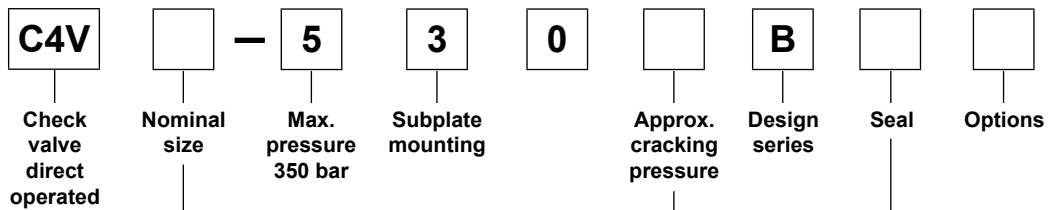

Code	Nominal size
03	NG10
06	NG25
10	NG32

Code	Seal
1	NBR
5	FPM

Code	Approx. cracking pressure [bar]	
	C4V03	C4V06/10
1	2.8	3.5
2	0.5	0.5
3	0.3	0.3
4	2.2	2.2
5	—	9.0
6	1.2	1.2
7	3.0	—

Technical data

General				
Nominal size		NG10	NG25	NG32
Subplate mounting	ISO 5781			
Mounting position	Unrestricted			
Ambient temperature	[°C]	-20...+60		
MTTF _D value	[years]	150		
Weight	[kg]	2.8	4.6	6.1
Hydraulic				
Max. operating pressure	[bar]	350		
Nominal flow	[l/min]	150	270	450
Fluid	Hydraulic oil according to DIN 51524			
Fluid temperature	[°C]	-20...+70 (NBR: -25...+70)		
Viscosity,	permitted	[cSt] / [mm ² /s]	20...400	
	recommended	[cSt] / [mm ² /s]	30...80	
Filtration	ISO 4406 (1999); 18/16/13			

Δp/Q performance curve

6

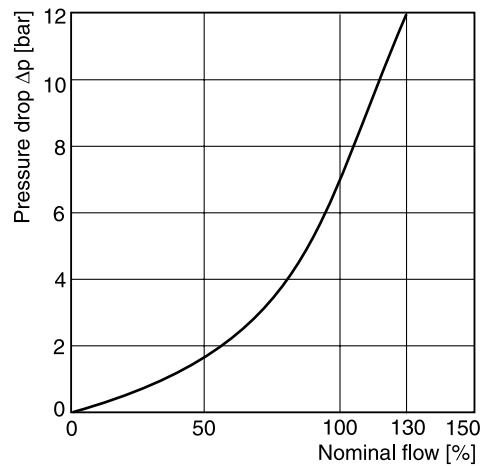

Characteristic curve measured with HLP46 at 50 °C.

Dimensions

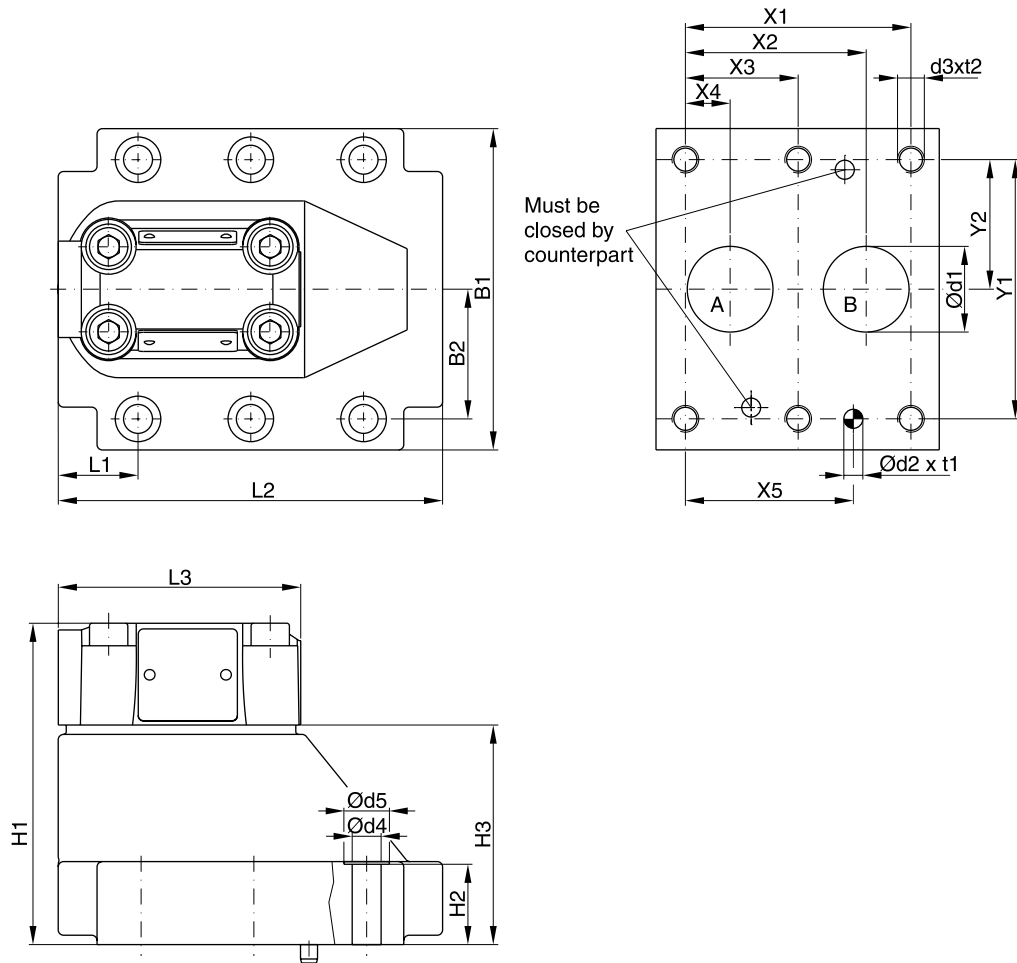



6

NG	ISO-code	x1	x2	x3	x4	x5	y1	y2	B1	B2	H1	H2	H3	L1	L2
10	5781-06-07-0-00	42.9	35.8	–	7.2	31.8	66.7	33.4	87.3	33.4	83	21	45	29	94.8
25	5781-08-10-0-00	60.3	49.2	–	11.1	44.5	79.4	39.7	105	39.7	107.5	29	69.5	34.7	126.8
32	5781-10-13-0-00	84.2	67.5	42.1	16.7	62.7	96.8	48.4	120	48.4	120	30	82	30.6	144.3

Tolerance for all dimensions ±0.2

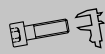
NG	ISO-code	d1max	d2	t1	d3	t2	d4	d5
10	5781-06-07-0-00	15	7.1	8	M10	16	10.8	17
25	5781-08-10-0-00	23.4	7.1	8	M10	18	10.8	17
32	5781-10-13-0-00	32	7.1	8	M10	20	10.8	17

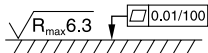
NG	ISO-code	Bolt kit			Kit		Surface finish
					NBR	FPM	
10	5781-06-07-0-00	BK505	4x M10x35 ISO 4762-12.9	63 Nm ±15 %	S26-58507-0	S26-58507-5	
25	5781-08-10-0-00	BK485	4x M10x45 ISO 4762-12.9	63 Nm ±15 %	S26-58475-0	S26-58475-5	
32	5781-10-13-0-00	BK506	6x M10x45 ISO 4762-12.9	63 Nm ±15 %	S26-58508-0	S26-58508-5	