

Parker Series CF Covers for 2-Way Slip-In Cartridge Valve Service Manual

Ordering Information

<div style="border: 1px solid black; width: 20px; height: 20px; margin: 0 auto; display: flex; align-items: center; justify-content: center; font-weight: bold;">C</div> <p>Cover</p>	<div style="border: 1px solid black; width: 20px; height: 20px; margin: 0 auto;"></div> <p>Nominal Size</p>	<div style="border: 1px solid black; width: 20px; height: 20px; margin: 0 auto; display: flex; align-items: center; justify-content: center; font-weight: bold;">F</div> <p>Cover with Pressure Relief Valve</p>	<div style="border: 1px solid black; width: 20px; height: 20px; margin: 0 auto;"></div> <p>Pressure Range</p>	<div style="border: 1px solid black; width: 20px; height: 20px; margin: 0 auto;"></div> <p>Pressure Adjustment</p>	<div style="display: flex; justify-content: space-around; width: 100%;"> <div style="border: 1px solid black; width: 20px; height: 20px; display: flex; align-items: center; justify-content: center; font-weight: bold;">1</div> <div style="border: 1px solid black; width: 20px; height: 20px; display: flex; align-items: center; justify-content: center; font-weight: bold;">2</div> <div style="border: 1px solid black; width: 20px; height: 20px; display: flex; align-items: center; justify-content: center; font-weight: bold;">3</div> </div> <p>Orifice / Choke</p>	<div style="border: 1px solid black; width: 20px; height: 20px; margin: 0 auto;"></div> <p>Seals</p>	<div style="border: 1px solid black; width: 20px; height: 20px; margin: 0 auto;"></div> <p>Design Series not required for ordering</p>
---	---	--	---	--	---	--	--

Code	Description
016	NG16
025	NG25
032	NG32

Code	Description
07	75 Bar (1088 PSI)
10	105 Bar (1522 PSI)
17	175 Bar (2538 PSI)
21	210 Bar (3000 PSI)
25	250 Bar (3625 PSI)
35	300 Bar (5075 PSI)

Code	Description
N	Nitrile
V	Fluorocarbon

Code	Description
99	Without Orifice, Open Orifice Options
00	Plug, Closed Orifice Options

Code	Description
S	Screw with Lock Nut
L	Knob E10 Lock

○ Orifice position

For orifice recommendations, bolt and seal kits, see Accessories in this chapter.

Dimensions

Inch equivalents for millimeter dimensions are shown in (**)

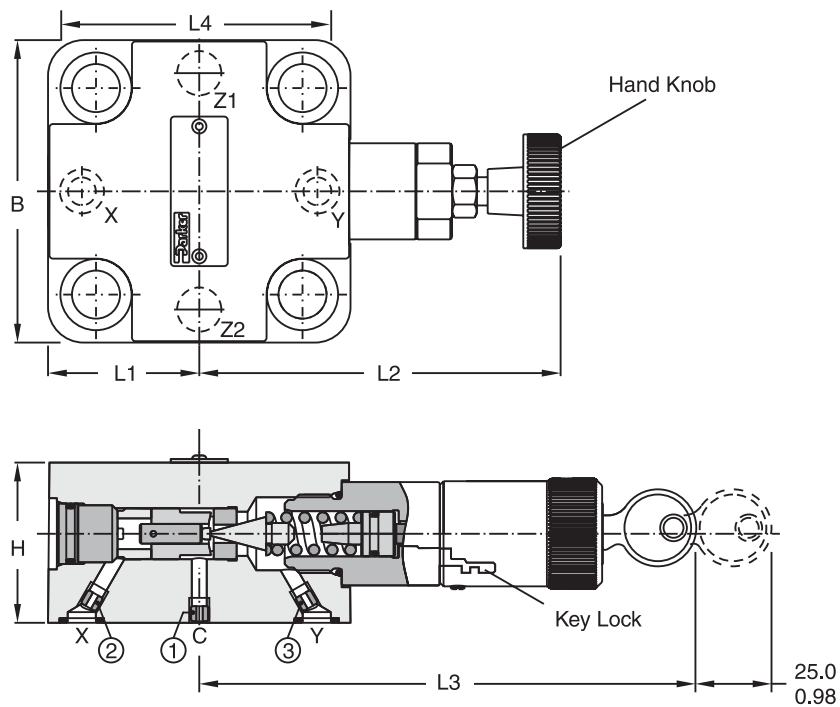

Ports Z1 and Z2: O-ring recess diameter on valve body

Size	B	H	L1	L2 max.	L3 max.	L4	Orifice Thread		
							①	②	③
NG16	65.0 (2.56)	40.0 (1.57)	32.5 (1.28)	114.0 (4.49)	125.5 (4.94)	79.0 (3.11)	M5	M4	M5
NG25	85.0 (3.35)	45.0 (1.77)	42.5 (1.68)	102.0 (4.02)	114.0 (4.49)	85.0 (3.35)	M5	M5	M5
NG32	102.0 (4.02)	50.0 (1.97)	51.0 (2.01)	95.0 (3.74)	106.0 (4.17)	102.0 (4.02)	M5	M6	M6