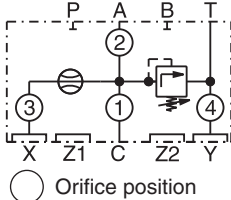

Parker Series CG Covers for 2-Way Slip-In Cartridge Valve Service Manual

Ordering Information

C Cover	Nominal Size	G Cover with Pressure Relief and Pilot System Mounting	Pressure Range	Pressure Adjustment	Orifice / Choke ① ② ③ ④	Seals	Design Series not required for ordering																																			
<table border="1" style="width: 100%; border-collapse: collapse;"> <thead> <tr><th>Code</th><th>Description</th></tr> </thead> <tbody> <tr><td>016</td><td>NG16</td></tr> <tr><td>025</td><td>NG25</td></tr> <tr><td>032</td><td>NG32</td></tr> </tbody> </table>		Code	Description	016	NG16	025	NG25	032	NG32	<table border="1" style="width: 100%; border-collapse: collapse;"> <thead> <tr><th>Code</th><th>Description</th></tr> </thead> <tbody> <tr><td>07</td><td>75 Bar (1088 PSI)</td></tr> <tr><td>10</td><td>105 Bar (1522 PSI)</td></tr> <tr><td>17</td><td>175 Bar (2538 PSI)</td></tr> <tr><td>21</td><td>210 Bar (3000 PSI)</td></tr> <tr><td>25</td><td>250 Bar (3625 PSI)</td></tr> <tr><td>35</td><td>300 Bar (5075 PSI)</td></tr> </tbody> </table>		Code	Description	07	75 Bar (1088 PSI)	10	105 Bar (1522 PSI)	17	175 Bar (2538 PSI)	21	210 Bar (3000 PSI)	25	250 Bar (3625 PSI)	35	300 Bar (5075 PSI)	<table border="1" style="width: 100%; border-collapse: collapse;"> <thead> <tr><th>Code</th><th>Description</th></tr> </thead> <tbody> <tr><td>S</td><td>Screw with Lock Nut</td></tr> <tr><td>L</td><td>Knob E10 Lock</td></tr> </tbody> </table>		Code	Description	S	Screw with Lock Nut	L	Knob E10 Lock	<table border="1" style="width: 100%; border-collapse: collapse;"> <thead> <tr><th>Code</th><th>Description</th></tr> </thead> <tbody> <tr><td>N</td><td>Nitrile</td></tr> <tr><td>V</td><td>Fluorocarbon</td></tr> </tbody> </table>		Code	Description	N	Nitrile	V	Fluorocarbon	
Code	Description																																									
016	NG16																																									
025	NG25																																									
032	NG32																																									
Code	Description																																									
07	75 Bar (1088 PSI)																																									
10	105 Bar (1522 PSI)																																									
17	175 Bar (2538 PSI)																																									
21	210 Bar (3000 PSI)																																									
25	250 Bar (3625 PSI)																																									
35	300 Bar (5075 PSI)																																									
Code	Description																																									
S	Screw with Lock Nut																																									
L	Knob E10 Lock																																									
Code	Description																																									
N	Nitrile																																									
V	Fluorocarbon																																									
				<table border="1" style="width: 100%; border-collapse: collapse;"> <thead> <tr><th>Code</th><th>Description</th></tr> </thead> <tbody> <tr><td>99</td><td>Without Orifice, Open Orifice Options</td></tr> <tr><td>00</td><td>Plug, Closed Orifice Options</td></tr> </tbody> </table>		Code	Description	99	Without Orifice, Open Orifice Options	00	Plug, Closed Orifice Options	 <p>○ Orifice position</p>																														
Code	Description																																									
99	Without Orifice, Open Orifice Options																																									
00	Plug, Closed Orifice Options																																									

For orifice recommendations, bolt and seal kits, see Accessories.

Dimensions

Inch equivalents for millimeter dimensions are shown in (**)

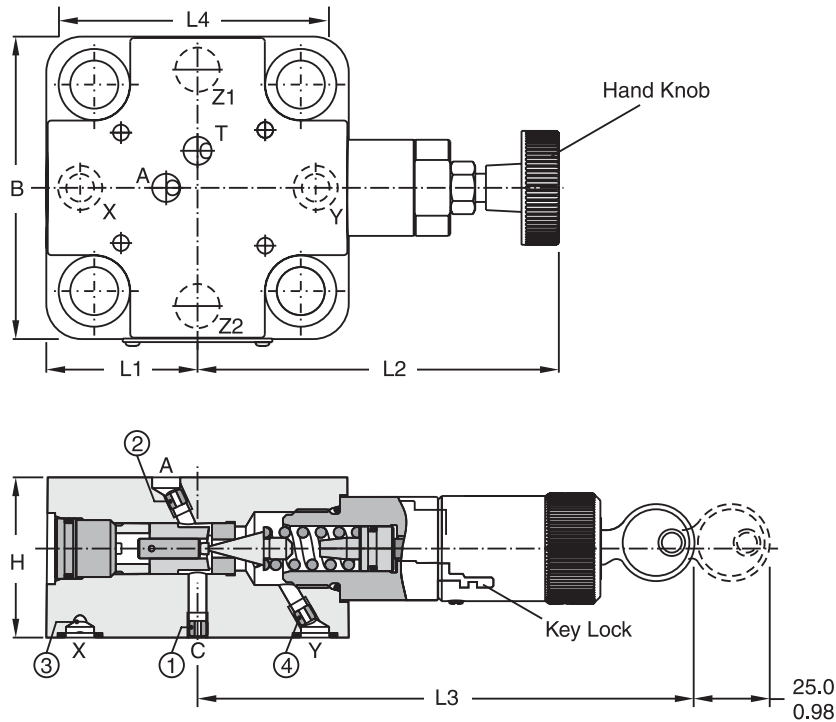

Size	B	H	L1	L2 max.	L3 max.	L4	Orifice Thread			
							①	②	③	④
NG16	65.0 (2.56)	40.0 (1.57)	32.5 (1.28)	114.0 (4.49)	125.5 (4.94)	79.0 (3.11)	M5	M5	M4	M5
NG25	85.0 (3.35)	45.0 (1.77)	42.5 (1.68)	102.0 (4.02)	114.0 (4.49)	85.0 (3.35)	M5	M5	M5	M5
NG32	102.0 (4.02)	50.0 (1.97)	51.0 (2.01)	95.0 (3.74)	106.0 (4.17)	102.0 (4.02)	M6	M6	M6	M6