

Parker Series D31FB OBE / D41FB OBE / D91FB OBE / D111FB OBE Pilot Operated Proportional Directional Control Valve Service Manual

Characteristics

The pilot operated proportional directional valves D*1FB are available in 4 sizes:

D31FB - NG10 (CETOP 05) D41FB - NG16 (CETOP 07) D91FB - NG25 (CETOP 08) D111FB - NG32 (CETOP 10)

The valves are available with and without onboard electronics (OBE).

3

FB OBE

The digital onboard electronics is situated in a robust metal housing, which allows the usage under rough environmental conditions.

The nominal values are factory set. The cable connection to a serial RS232 interface is available as accessory.

D*1FB for external electronics

The parameters can be saved, changed and duplicated in combination with the digital power amplifier PWD00A-400. The valve parameters can be edited with the common ProPx software for both versions.

The D*1FB valves work with barometric feedback of the main stage to the pressure reducing pilot valve. The pilot control pressure of 25 bar allows high flow rates at maximum stability.

The innovative integrated regenerative function into the A-line (optional) allows energy saving circuits for differential cylinders. The hybrid version can be switched between regenerative mode and standard mode at any time. Valves with explosion proof solenoids Ex e mb II see catalogue HY11-3343.

Download : www.parker.com/euro_hcd - see "Literature"

D91FB OBE



D91FB OBE

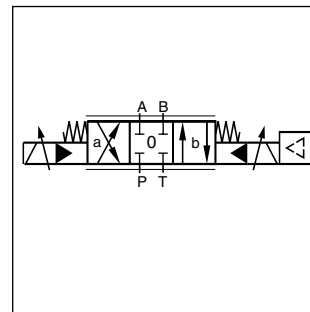

Standard D*1FB OBE

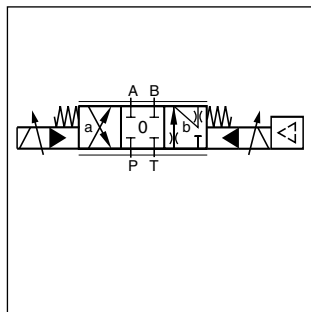

A-regeneration D*1FB R OBE

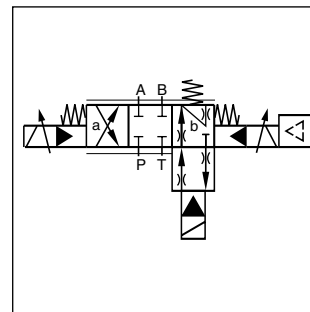

Hybrid D*1FB Z OBE

Technical Features

- Progressive flow characteristics for sensitive adjustment of flow rate
- High flow capacity
- Digital onboard electronics optional
- Centre position monitoring optional
- Energy saving A-regeneration optional
- Switchable hybrid version optional

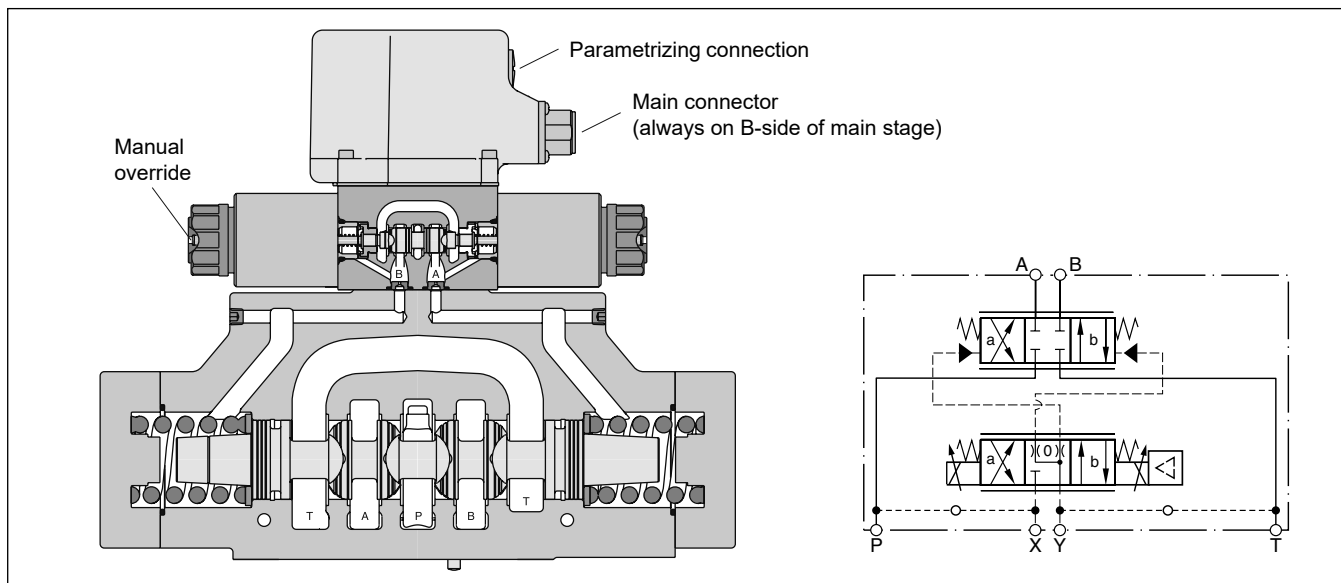

D*1FBR and D*1FBZ

Regenerative valve D*1FBR

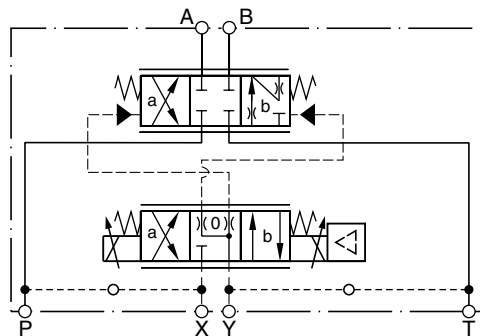
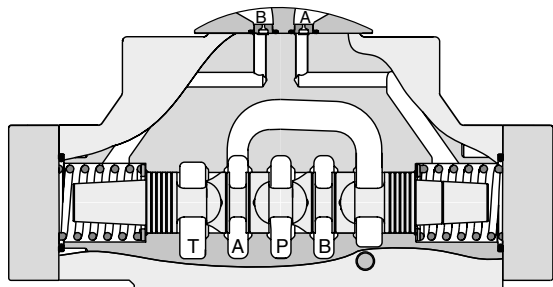

Hybrid valve D*1FBZ

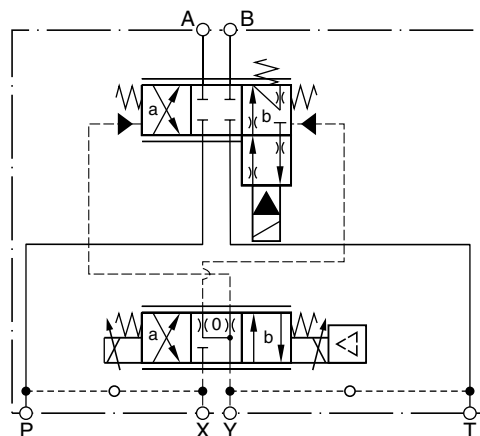
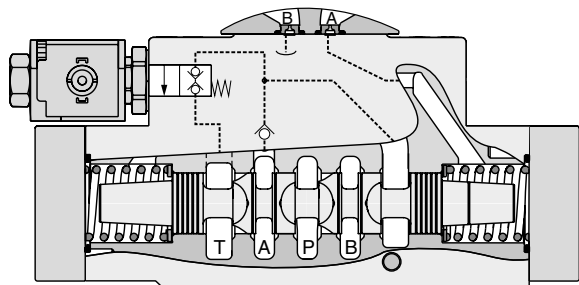

**D*1FBR (regenerative valve)
 Cylinder extending**

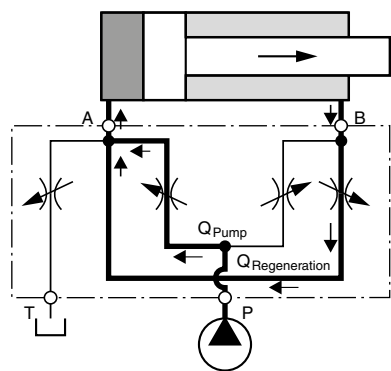

**D*1FBZ (hybrid valve)
 Cylinder extending
 regenerative mode
 (high speed)**

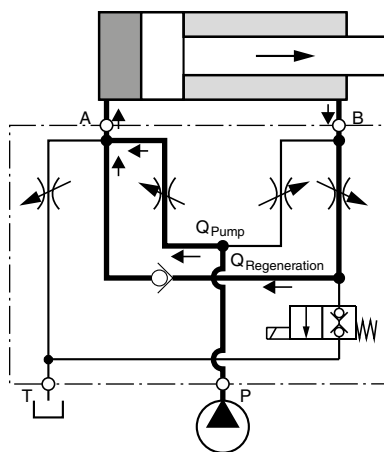

**Cylinder extending
 standard mode
 (high force)**

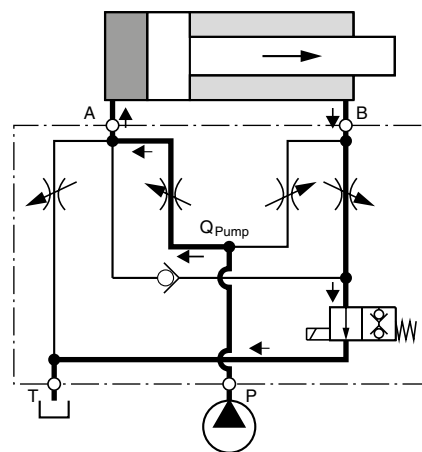

Flow rate in % of nominal flow

Size ¹⁾	spool	Port					
		A-T	P-A	P-B	B-A (R-valve)	B-A (hybrid)	B-T (hybrid)
D41FBR/Z	31/32	100 %	50 %	100 %	50 %	45 %	20 %
D91FBR/Z	31/32	100 %	50 %	100 %	50 %	50 %	25 %
D111FBR/Z	31/32	100 %	50 %	100 %	50 %	50 %	20 %

¹⁾ D31FB: For size NG10 please refer solution with sandwich- and adaptor plates "A10-1664 / A10-1665L / H10-1662 / H10-1666L" in chapter 12.

Ordering Code

D*1FB

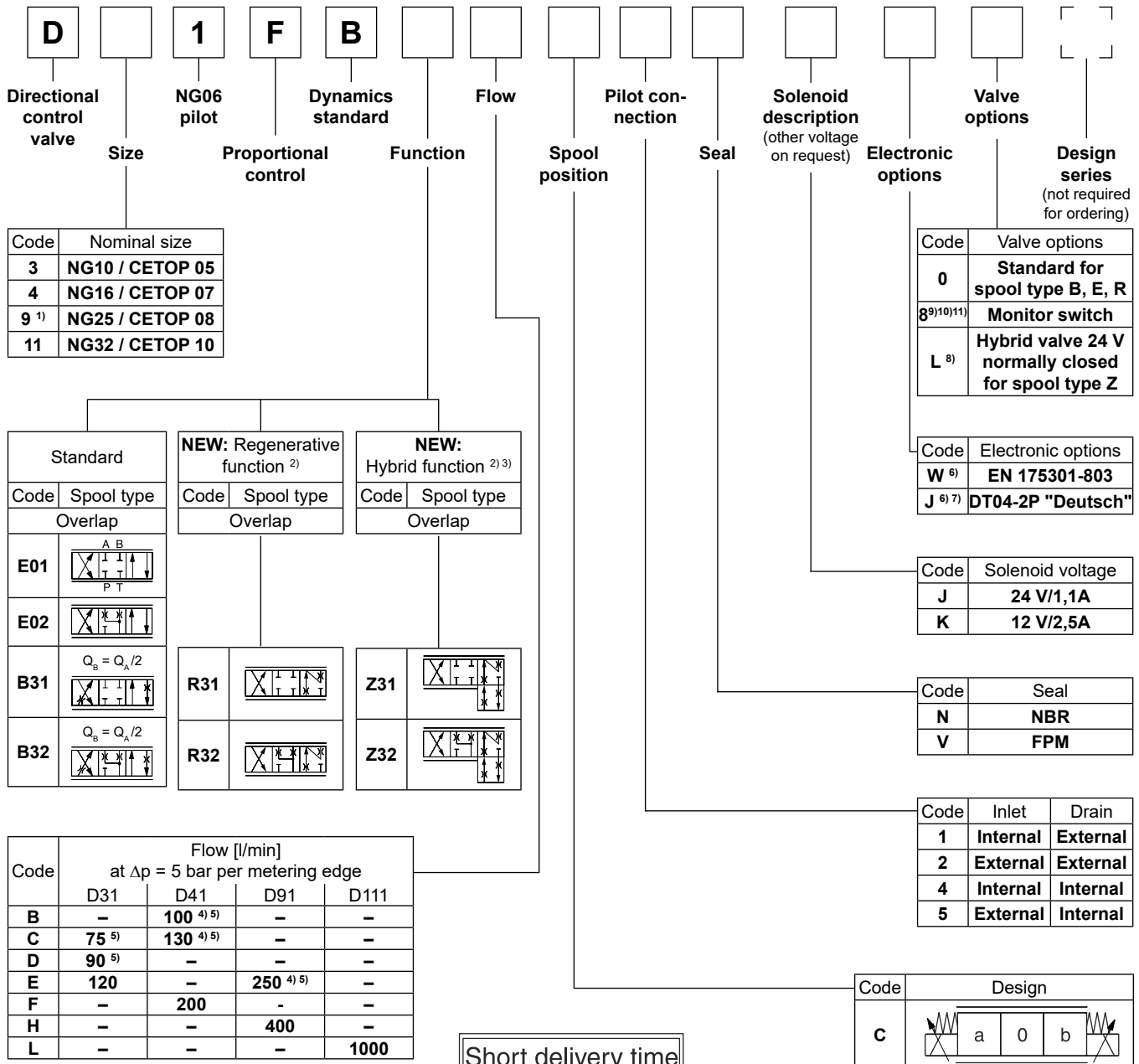

Code	Nominal size
3	NG10 / CETOP 05
4	NG16 / CETOP 07
9 ¹⁾	NG25 / CETOP 08
11	NG32 / CETOP 10

Standard		NEW: Regenerative function ²⁾		NEW: Hybrid function ²⁾³⁾	
Code	Spool type	Code	Spool type	Code	Spool type
Overlap					
E01					
E02					
B31	$Q_B = Q_A/2$ 	R31		Z31	
B32	$Q_B = Q_A/2$ 	R32		Z32	

Code	Flow [l/min]			
	at $\Delta p = 5$ bar per metering edge			
	D31	D41	D91	D111
B	-	100 ⁴⁾⁵⁾	-	-
C	75 ⁵⁾	130 ⁴⁾⁵⁾	-	-
D	90 ⁵⁾	-	-	-
E	120	-	250 ⁴⁾⁵⁾	-
F	-	200	-	-
H	-	-	400	-
L	-	-	-	1000

Code	Valve options
0	Standard for spool type B, E, R
8 ⁹⁾¹⁰⁾¹¹⁾	Monitor switch
L ⁸⁾	Hybrid valve 24 V normally closed for spool type Z

Code	Electronic options
W ⁶⁾	EN 175301-803
J ⁶⁾⁷⁾	DT04-2P "Deutsch"

Code	Solenoid voltage
J	24 V/1,1A
K	12 V/2,5A

Code	Seal
N	NBR
V	FPM

Code	Inlet	Drain
1	Internal	External
2	External	External
4	Internal	Internal
5	External	Internal

Code	Design
C	
E ⁵⁾	
K ⁵⁾	

Short delivery time for all variations

¹⁾ With enlarged connections $\varnothing 32$ mm.

²⁾ For regenerative and hybrid function at D31FB (NG10) please refer solutions with sandwich- and adaptor plates "A10-1664 / A10-1665L / H10-1662 / H10-1666L" in chapter 12.



³⁾ Not for D31FB.

⁴⁾ Not for spool type B31 und B32.

⁵⁾ Not for regenerative and hybrid function.

⁶⁾ Please order plugs separately. See accessories.

⁷⁾ Not for hybrid function.

⁸⁾ See page "regenerative and hybrid function" (not for D31FB).

⁹⁾ Not for D111FBZ*.

¹⁰⁾ Monitor switch for hybrid valves: code 8 includes options of code L (24 V normally closed).

¹¹⁾ Please order female connector M12x1 separately (see accessories , female connector M12x1 (order no.: 5004109).

D*1FB OBE

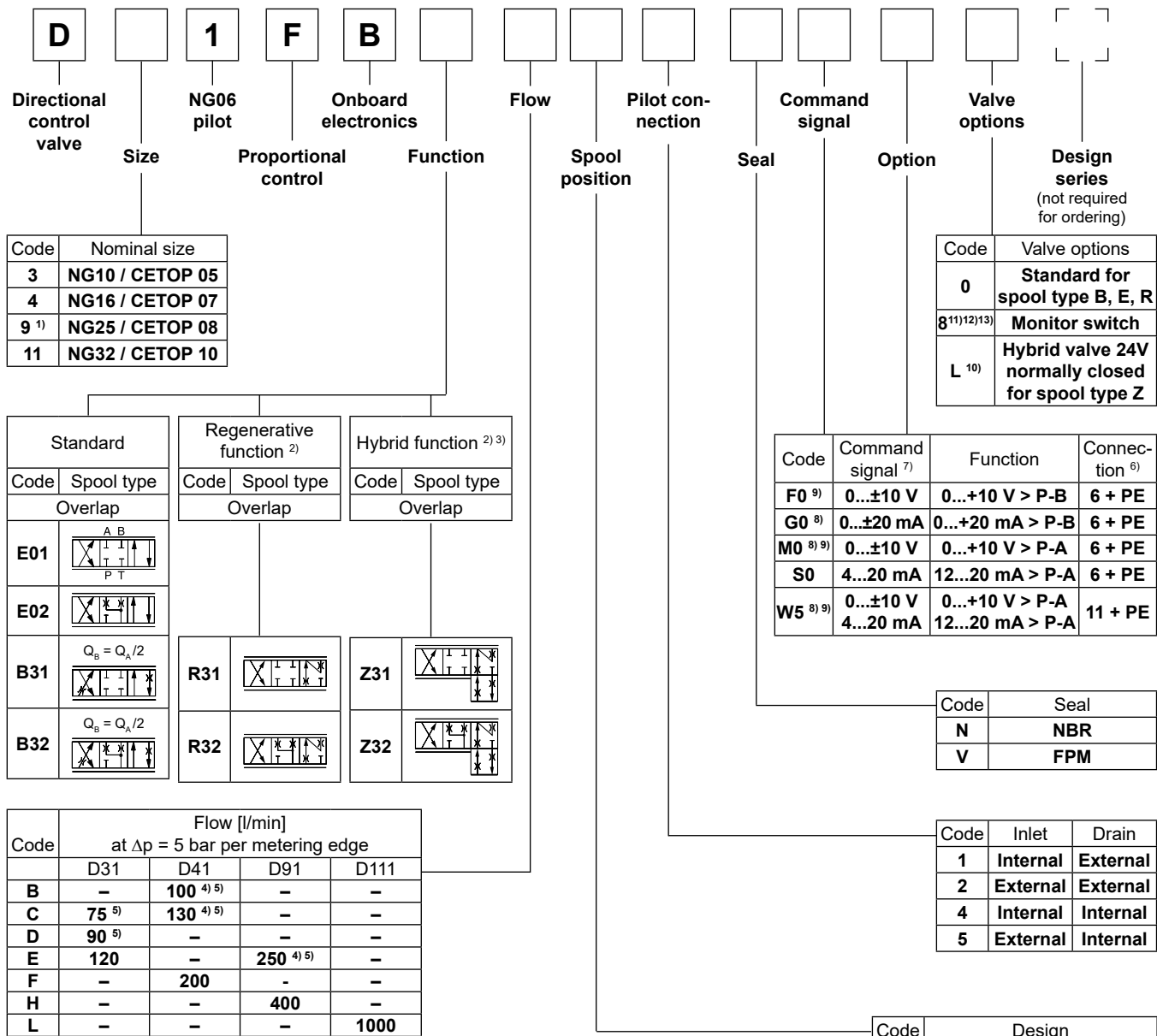

3

Parametrizing cable OBE →
 RS232, item no. 40982923

Short delivery time
 for all variations

- ¹⁾ With enlarged connections Ø 32 mm.
- ²⁾ For regenerative and hybrid function at D31FB (NG10) please refer solutions with sandwich- and adaptor plates "A10-1664 / A10-1665L / H10-1662 / H10-1666L" in chapter 12.

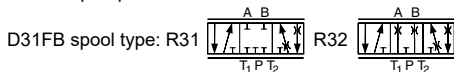

- ³⁾ Not for D31FB.
- ⁴⁾ Not for spool type B31 und B32.
- ⁵⁾ Not for regenerative and hybrid function.
- ⁶⁾ Please order plugs separately, see accessories.
- ⁷⁾ For 1 solenoid 0...+10 V respectively 4...20 mA.
- ⁸⁾ Not for spool position E and K.
- ⁹⁾ F0, M0 potentiometer supply, W5 command channel & potentiometer supply.
- ¹⁰⁾ See page "regenerative and hybrid function" (not for D31FB).
- ¹¹⁾ Not for D111FBZ*.
- ¹²⁾ Monitor switch for hybrid valves: code 8 includes options of code L (24 V normally closed).
- ¹³⁾ Please order female connector M12x1 separately (see accessories , female connector M12x1 (order no.: 5004109)

Technical Data

General				
Design	Pilot operated DC valve			
Actuation	Proportional solenoid			
Size	NG10 (CETOP 05)	NG16 (CETOP 07)	NG25 (CETOP 08)	NG32 (CETOP 10)
Mounting interface	DIN 24340 / ISO 4401 / CETOP RP121 / NFPA			
Mounting position	unrestricted			
Ambient temperature	-20...+60			
MTTF _D value ¹⁾	75			
Weight (OBE)	8.6 (9.3)	11.9 (12.6)	20.4 (21.1)	68 (68.7)
Hydraulic				
Max. operating pressure	Pilot drain internal: P, A, B, X 350; T, Y 185			
Fluid	Pilot drain external: P, A, B, T, X 350; Y 185			
Fluid temperature	Hydraulic oil according to DIN 51524 ... 535, other on request			
Viscosity permitted	-20...+60 (NBR: -25...+60)			
Viscosity recommended	20...400			
Filtration	30...80			
Nominal flow at Δp=5 bar per control edge ²⁾	ISO 4406; 18/16/13			
Leakage at 100 bar	75/90/120	130/200	250/400	1000
Opening point (OBE)	100	200	600	1000
Pilot supply pressure	see flow characteristics (set to 10 command signal)			
Pilot flow at 100 bar	min. 30 (+ T/Y pressure)			
Pilot flow, step response	max. 350			
	optimal dynamics at 50			
	<0.5	<1.2	<1.2	<1.2
	2.0	1.9	4.5	18
Static / Dynamic				
Step response at 100 % step	50	75	100	180
Hysteresis	<5			
Electrical characteristics				
Duty ratio	100 ED; CAUTION: Coil temperature up to 150 °C possible			
Protection class	Standard (as per EN175301-803) IP65 in accordance with EN 60529			
Solenoid Code	DT04-2P "Deutsch" IP69K (with correctly mounted plug-in connector)			
Supply voltage	K	J		
Current consumption	12	24		
Resistance	2.5	1.1		
	4.4	18.6		
Solenoid connection	Connector as per EN 175301-803 (code W),			
Wiring min.	DT04-2P "Deutsch" connector (code J). Solenoid identification as per ISO 9461.			
Wiring length max.	3x1.5 (AWG 16) overall braid shield			
	50			

Electrical characteristics (hybrid option)				
Duty ratio	100 ED; CAUTION: Coil temperature up to 150 °C possible			
Protection class	IP 65 in accordance with EN 60529 (with correctly mounted plug-in connector)			
	D41	D91	D111	
Supply voltage	24	24	24	
Tolerance supply voltage	±10	±10	±10	
Current consumption	1.21	0.96	1.29	
Power consumption	29	23	31	
Solenoid connection	Connector as per EN 175301-803			
Wiring min.	3 x 1.5 recommended			
Wiring length max.	50 recommended			

¹⁾ If valves with onboard electronics are used in safety-related parts of control systems, in case the safety function is requested, the valve electronics voltage supply is to be switched off by a suitable switching element with sufficient reliability.

²⁾ Flow rate for different Δp per control edge:

$$Q_x = Q_{Nom.} \cdot \sqrt{\frac{\Delta p_x}{\Delta p_{Nom.}}}$$

Electrical characteristics (D*1FB OBE)			
Vibration resistance	[g]	10 Sinus 5...2000 Hz acc. IEC 68-2-6 10 (RMS) Random noise 20...2000 Hz acc. IEC 68-2-36 15 Shock acc. IEC 68-2-27	
Duty ratio	[%]	100 ED; CAUTION: coil temperature up to 150 °C possible	
Protection class		IP65 in accordance with EN 60529 (with correctly mounted plug-in connector)	
Supply voltage/ripple DC	[V]	18...30, ripple < 5 % eff., surge free	
Current consumption max.	[A]	2.0	
Pre fusing medium lag	[A]	2.5	
Input signal			
Codes F0, M0, W5 voltage	[V]	+10...0...-10, ripple < 0.01 % eff., surge free, Ri = 100 kOhm	
Code G0 current	[mA]	+20...0...-20, ripple < 0.01 % eff., surge free, Ri = <250 Ohm	
Codes S0 & W5 current	[mA]	4...12...20, ripple < 0.01 % eff., surge free, Ri = <250 Ohm < 3.6 mA = enable off, > 3.8 mA = enable on (acc. to NAMUR NE43)	
Differential input max.			
Codes F0, M0 G0 & S0	[V]	30 for terminal D and E against PE (terminal G) 11 for terminal D and E against 0V (terminal B)	
Code W5	[V]	30 for terminal 4 and 5 against PE (terminal PE) 11 for terminal 4 and 5 against 0V (terminal 2)	
Channel recall signal	[V]	0...2.5: off / 5...30: on / Ri = 100 kOhm	
Adjustment ranges			
Min	[%]	0...50	
Max	[%]	50...100	
Ramp	[s]	0...32.5	
Interface		RS 232, parametrizing connection 5pole	
EMC		EN 61000-6-2, EN 61000-6-4	
Central connection			
Codes F0, M0 G0 & S0		6 + PE acc. to EN 175201-804	
Code W5		11 + PE acc. to EN 175201-804	
Wiring min.			
Codes F0, M0 G0 & S0	[mm ²]	7 x 1.0 (AWG16) overall braid shield	
Code W5	[mm ²]	11 x 1.0 (AWG16) overall braid shield	
Wiring length max.		50	

With electrical connections the protective conductor (PE ⚡) must be connected according to the relevant regulations.

D*1FB B/E Flow characteristics

at Δp = 5 bar per metering edge

Spool code **E01/02**

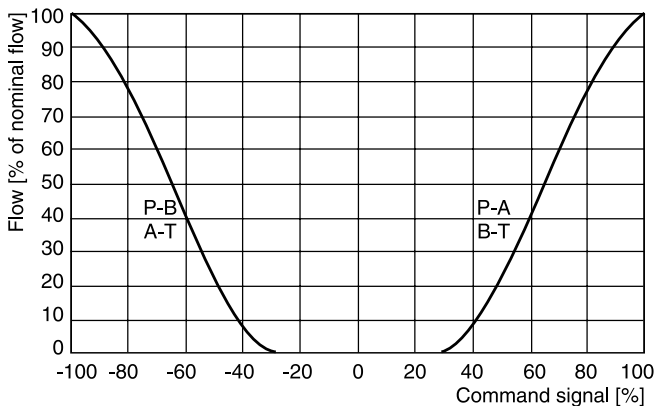

Spool code **B31/32***

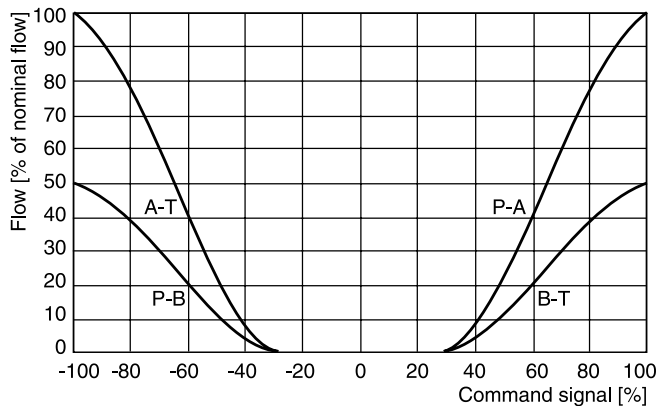

All characteristic curves measured with HLP46 at 50 °C.

Characteristic Curves

D*1FB B/E OBE

Flow characteristics

(set to opening point 10 %)

at $\Delta p = 5$ bar per metering edge

Spool code **E01/02**

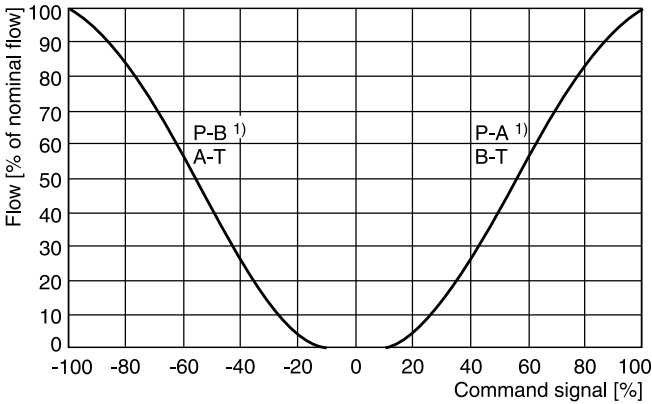

Spool code **B31/32**

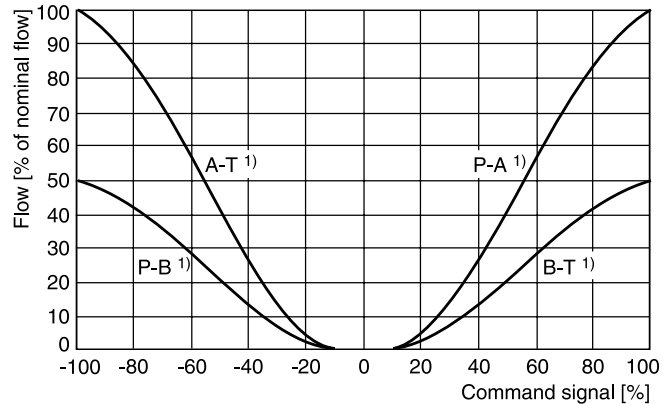

D*1FB R/Z (regenerative and hybrid)

D41FB R/Z

Spool code **R/Z31/32**

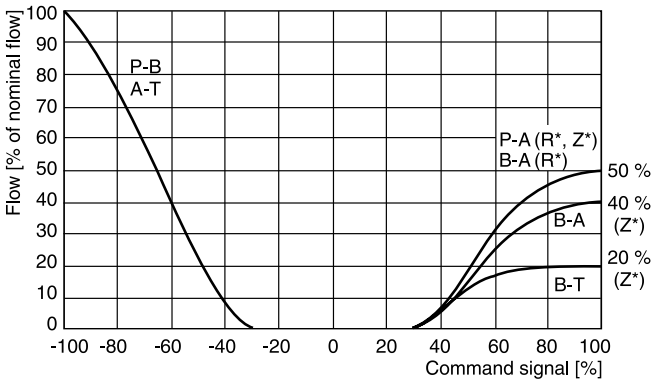

D91FB R/Z

Spool code **R/Z31/32**

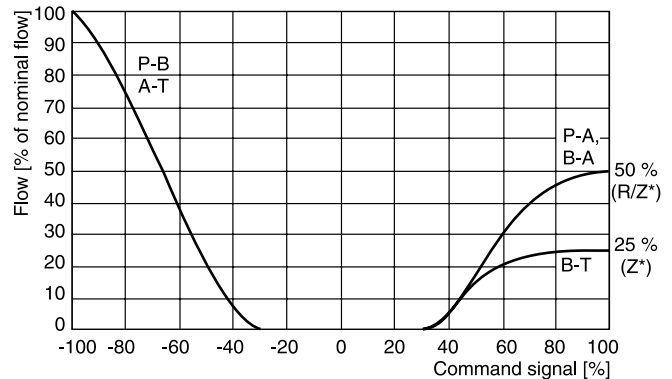

D41FB R/Z OBE

Spool code **R/Z31/32**

(set to opening point 10 %)

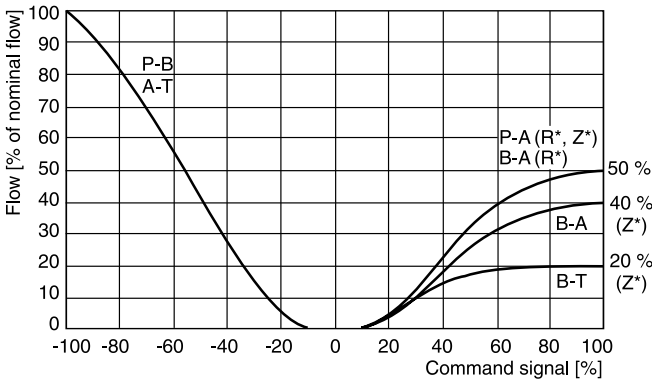

D91FB R/Z OBE

Spool code **R/Z31/32**

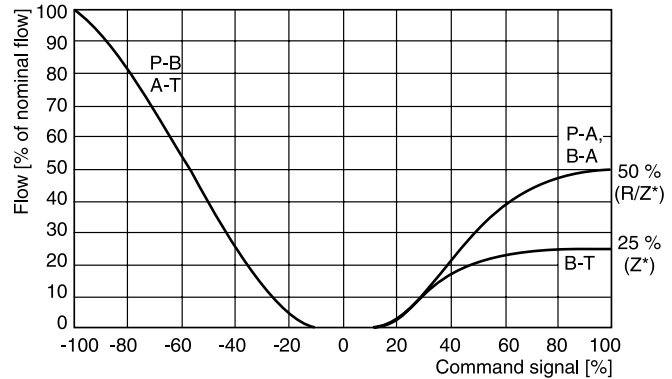

All characteristic curves measured with HLP46 at 50 °C.

¹⁾ Flow direction depending on ordering code.

Electrical characteristics of position control M12x1 as per IEC 61076-2-101

Supply voltage	[VDC]	24
Tolerance supply voltage	[%]	±20
Ripple supply voltage	[%]	≤10
Polarity protection	[V]	300
Current consumption without load	[mA]	≤20
Switching hysteresis	[mm]	<0.06
Max. output current per channel, ohmic	[mA]	250
Ambient temperature	[°C]	-20 ... +60
Protection		IP65 acc. EN 60529
CE conform		EN 61000-4-2 / EN 61000-4-4 / EN 61000-4-6 ¹⁾ / ENV 50140 / ENV 50204
Min. distance to next AC solenoid	[m]	0.1
Interface		M12x1 to IEC 61076-2-101

3

M12 pin assignment

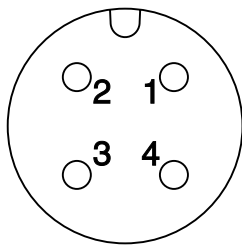

- 1 + U_s 19.2...28.8 V
- 2 Out B: normally open
- 3 0V
- 4 Out A: normally closed

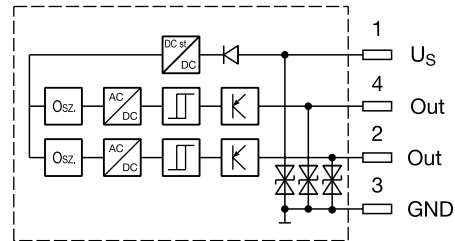

Outputs: Open collector

Signal	Output A (pin 4)	Output B (pin 2)
neutral	closed	closed
	open	closed
	closed	open

The neutral position is monitored. The signal changes after less than 10 % of the spool stroke.

Please order female connector M12x1 separately (see accessories, female connector M12x1 (order no.: 5004109)).

¹⁾ Only guaranteed with screened cable and female connector

Block Diagrams

Code F0, M0
6 + PE acc. to EN 175201-804

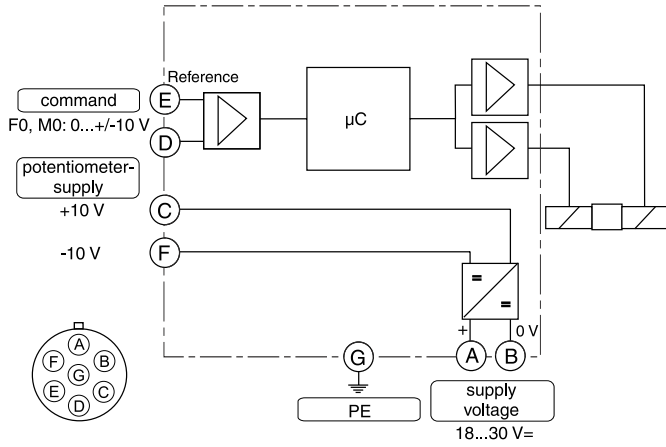

Code G0, S0
6 + PE acc. to EN 175201-804

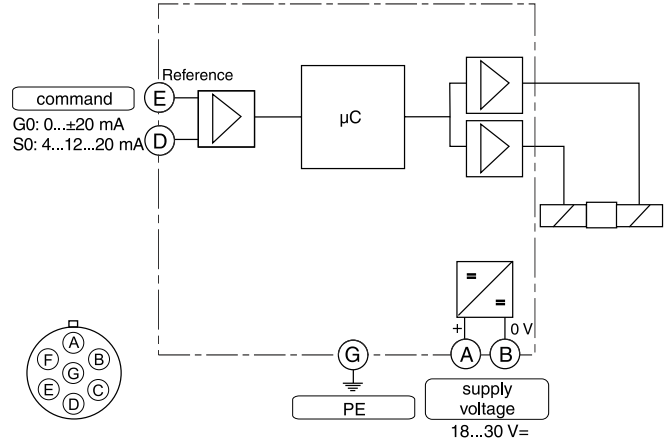

Code W5
11 + PE acc. to EN 175201-804

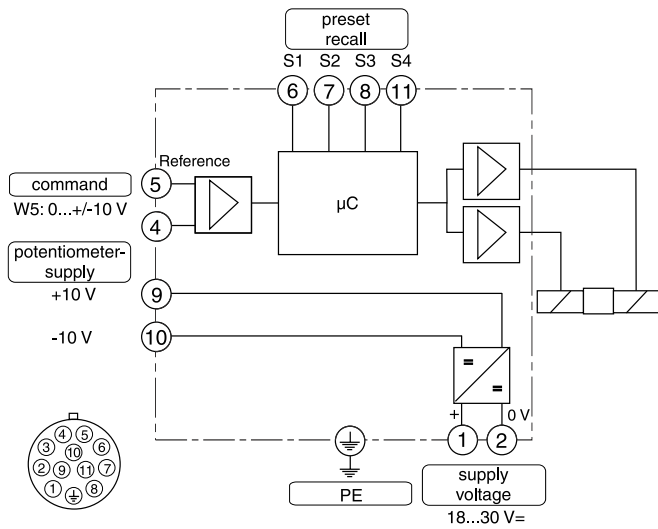

ProPxD interface program

The ProPxD software permits comfortable parameter setting for the module electronics. Via the clearly arranged entry mask the parameters can be noticed and modified. Storage of complete parameter sets is possible as well as printout or record as a text file for further documentation. Stored parameter sets may be loaded anytime and transmitted to other valves. Inside the electronics a non-volatile memory stores the data with the option for recalling or modification.

The PC software can be downloaded free of charge at www.parker.com/isde – see page "Support" or directly at www.parker.com/propxd.

Features

- Comfortable editing of all parameters
- Depiction and documentation of parameter sets
- Storage and loading of optimized parameter adjustments
- Executable with all actual Windows® operating systems from Windows® XP upwards
- Plain communication between PC and electronics via serial interface RS232C

The parametrizing cable may be ordered under item no. 40982923.

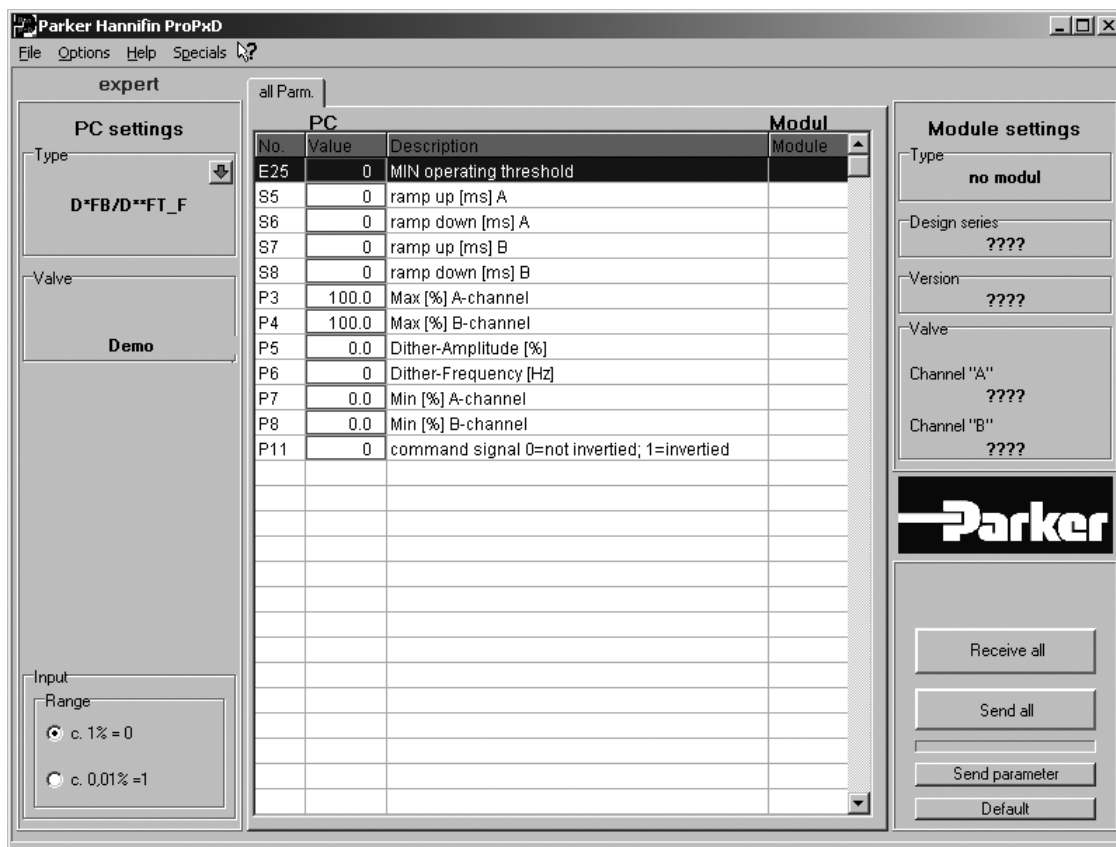

Pilot Flow

Pilot oil inlet (supply) and outlet (drain)

○ open, ● closed

Pilot oil		B	C
Inlet	Drain		
internal	external	○	●
external	external	●	●
internal	internal	○	○
external	internal	●	○

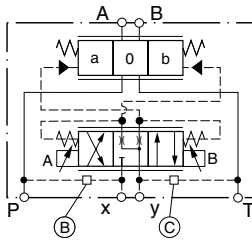

3

D31FBB/E

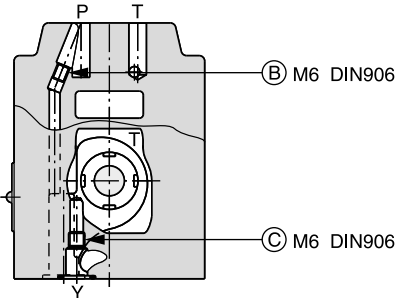

D31FBR

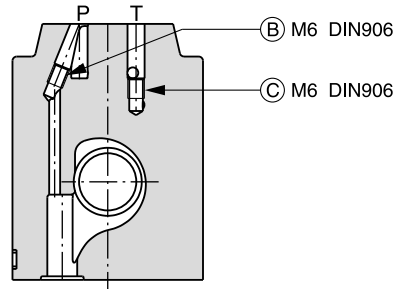

D41FBB/E

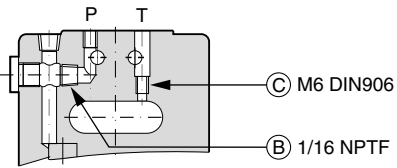

D41FBR

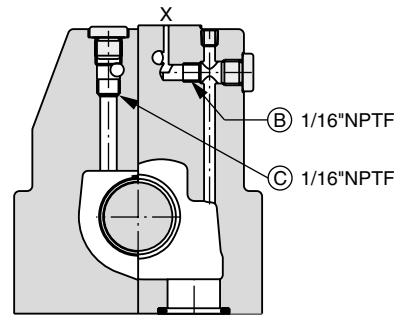

D41FBZ

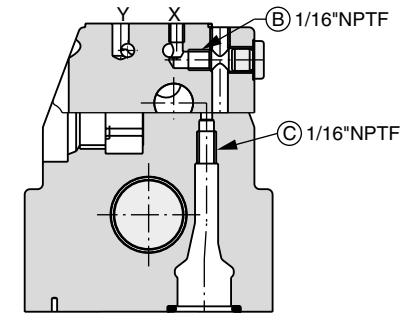

D91FBB/E

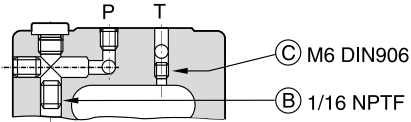

D91FBR

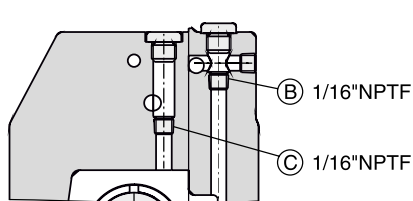

D91FBZ

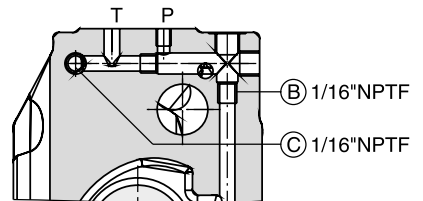

D111FBB/E

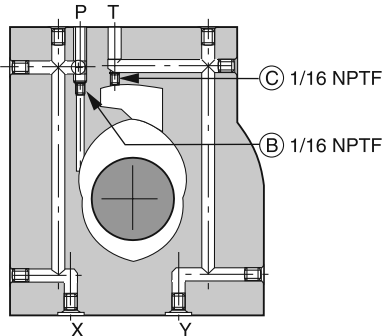

D111FBR

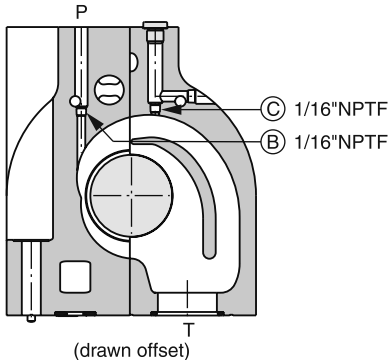

D111FBZ

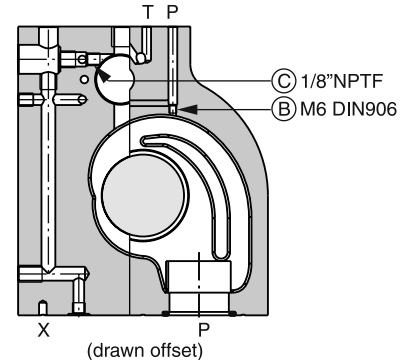

D31FB

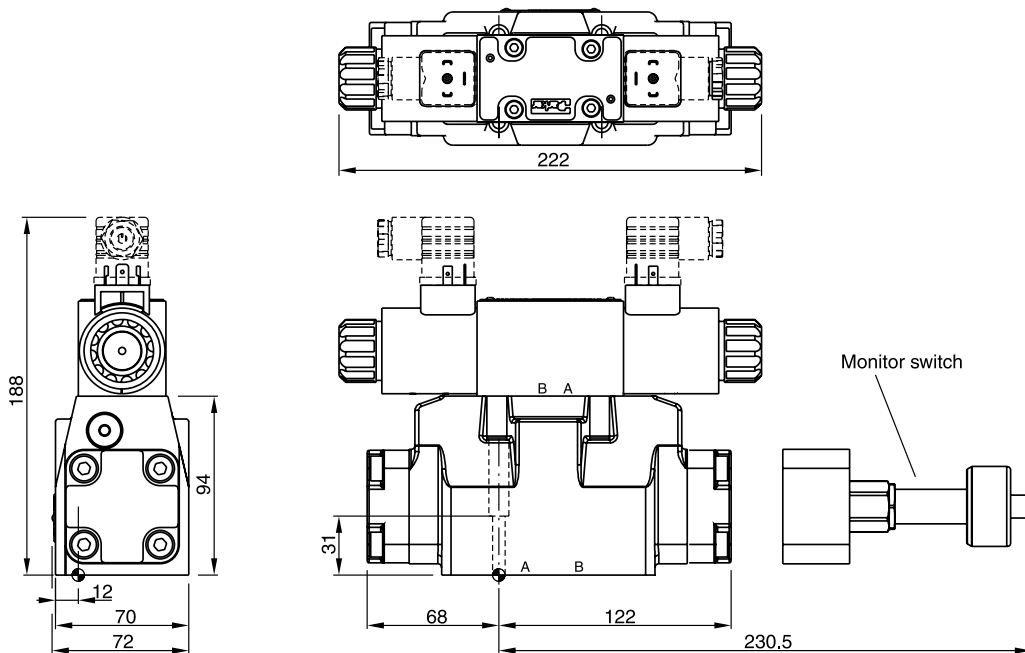

Regenerative and hybrid function with additional plate "H10-1666L / H10-1662 / A10-1664 / A10-1665L", see chapter 12.

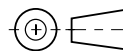

Surface finish	Kit	Kit	Kit	Kit
	BK385	4x M6x40 ISO 4762-12.9	13.2 Nm ±15 %	NBR: SK-D31FB FPM: SK-D31FB-V

D41FB

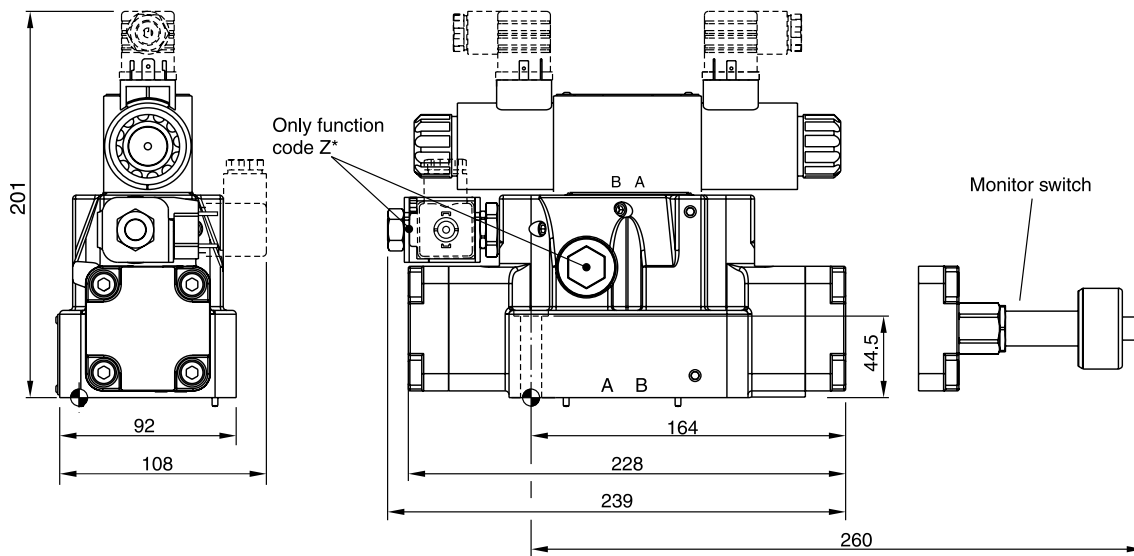

Surface finish	Kit	Kit	Kit	Kit
	BK320	2x M6x55 4x M10x60 ISO 4762-12.9	13.2 Nm ±15 % 63 Nm ±15 %	NBR: SK-D41FB FPM: SK-D41FB-V

Dimensions

D91FB

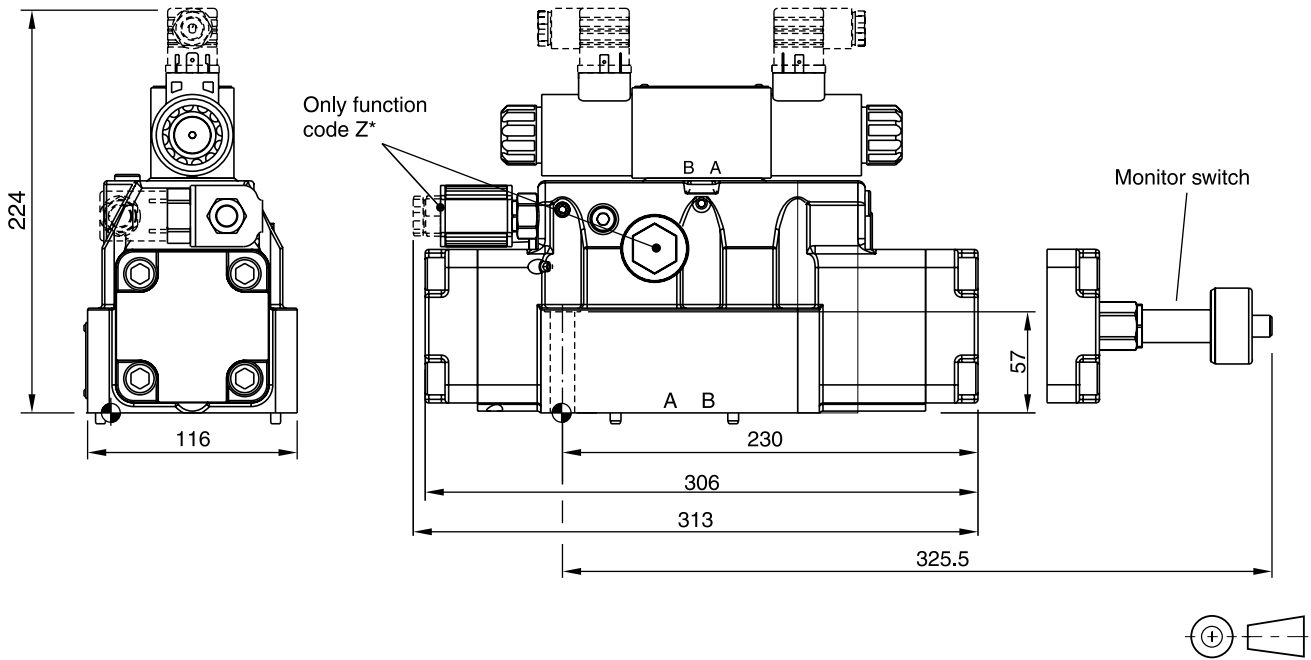

Surface finish	Kit	Kit	Kit	Kit
$\sqrt{R_{max} 6.3}$ $\square 0.01/100$	BK360	6x M12x75 ISO 4762-12.9	108 Nm ±15 %	NBR: SK-D91FB FPM: SK-D91FB-V

D111FB

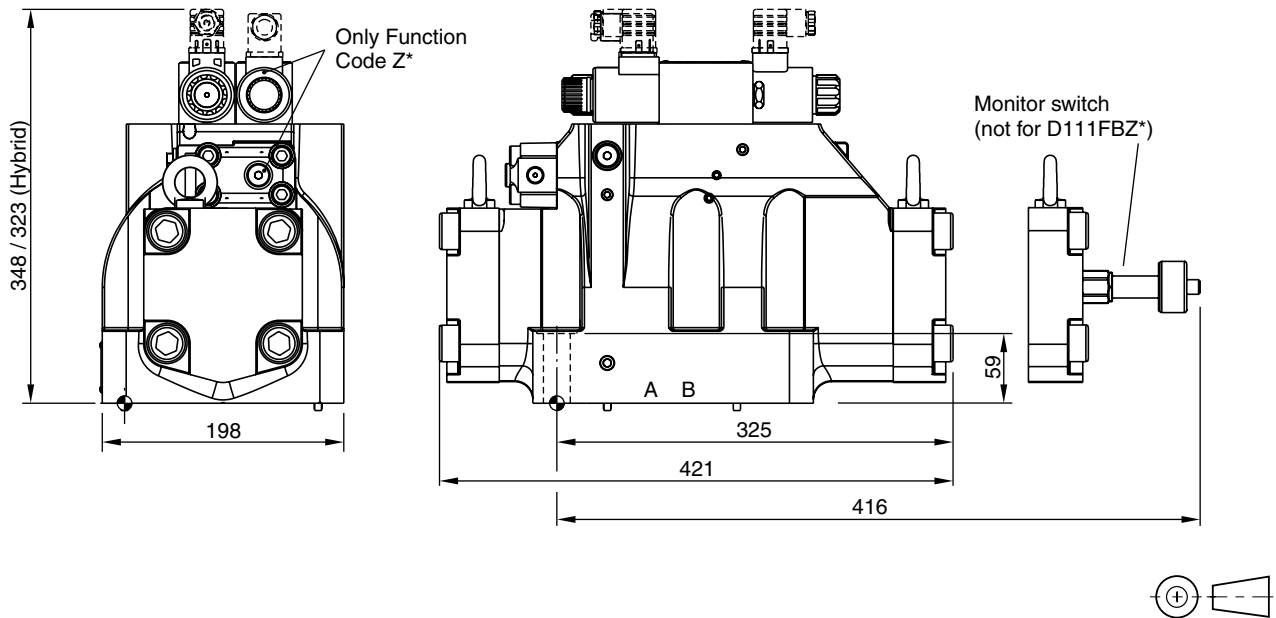

Surface finish	Kit	Kit	Kit	Kit
$\sqrt{R_{max} 6.3}$ $\square 0.01/100$	BK386	6x M20x90 ISO 4762-12.9	517 Nm ±15 %	NBR: SK-D111FB FPM: SK-D111FB-V

Dimension with DT04-2P "Deutsch" Connector

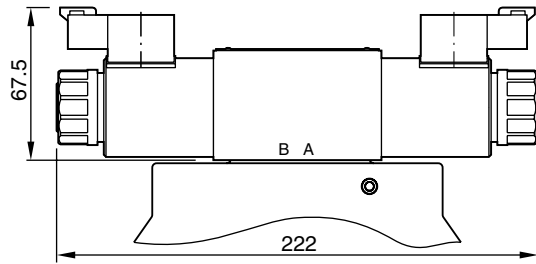

Dimensions

Pilot Operated Proportional DC Valve Series D*1FB OBE

D31FB OBE

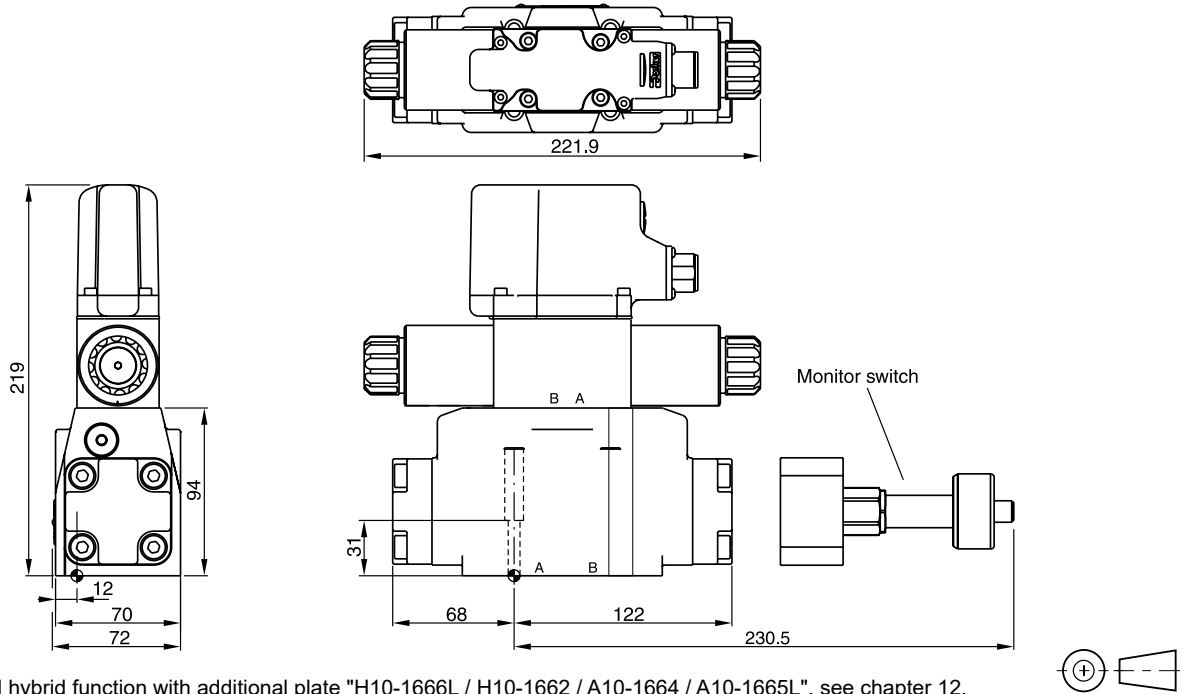

Regenerative and hybrid function with additional plate "H10-1666L / H10-1662 / A10-1664 / A10-1665L", see chapter 12.

Surface finish	Kit			Kit
$\sqrt{R_{max}6.3}$ $\square 0.01/100$	BK385	4x M6x40 ISO 4762-12.9	13.2 Nm $\pm 15\%$	NBR: SK-D31FB FPM: SK-D31FB-V

D41FB OBE

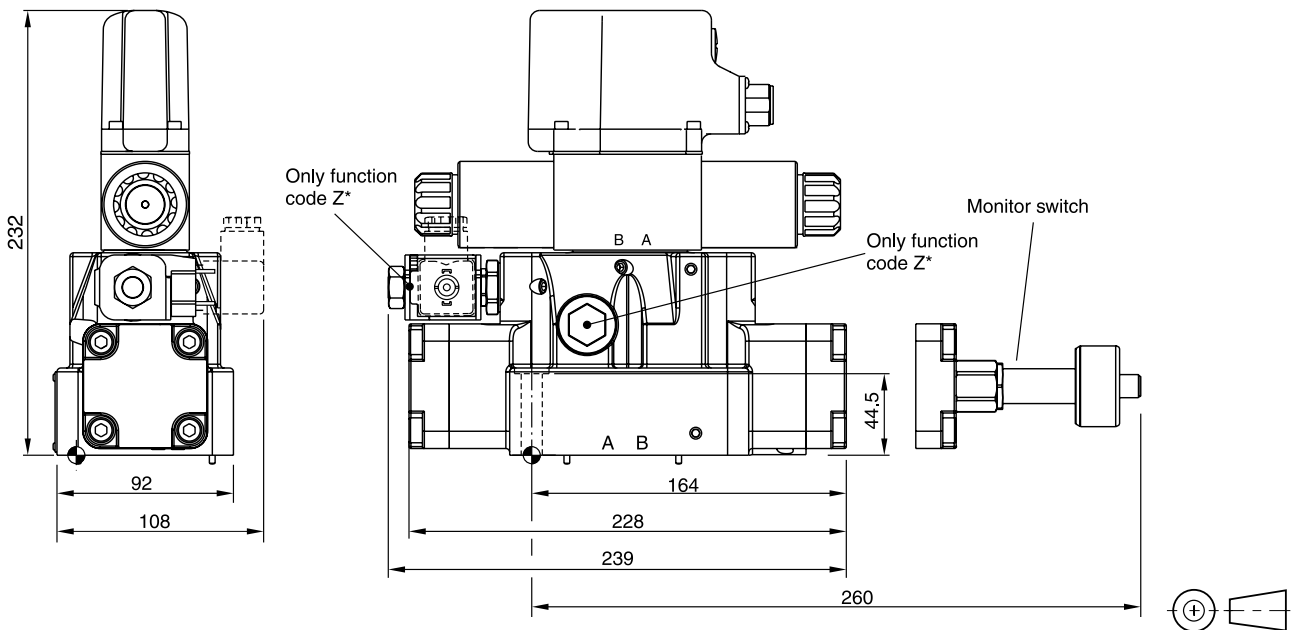

Surface finish	Kit			Kit
$\sqrt{R_{max}6.3}$ $\square 0.01/100$	BK320	2x M6x55 4x M10x60 ISO 4762-12.9	13.2 Nm $\pm 15\%$ 63 Nm $\pm 15\%$	NBR: SK-D41FB FPM: SK-D41FB-V

D91FB OBE

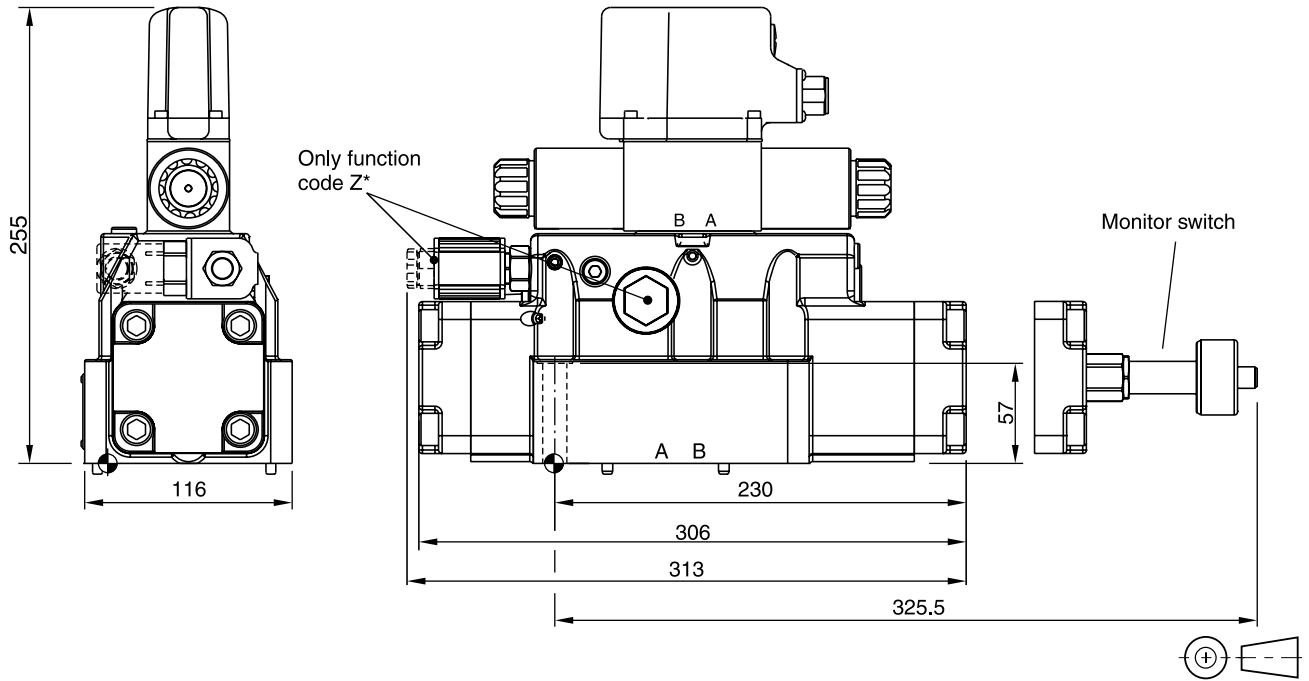

Surface finish	Kit	Kit	Kit	Kit
	BK360	6x M12x75 ISO 4762-12.9	108 Nm ±15 %	NBR: SK-D91FB FPM: SK-D91FB-V

D111FB OBE

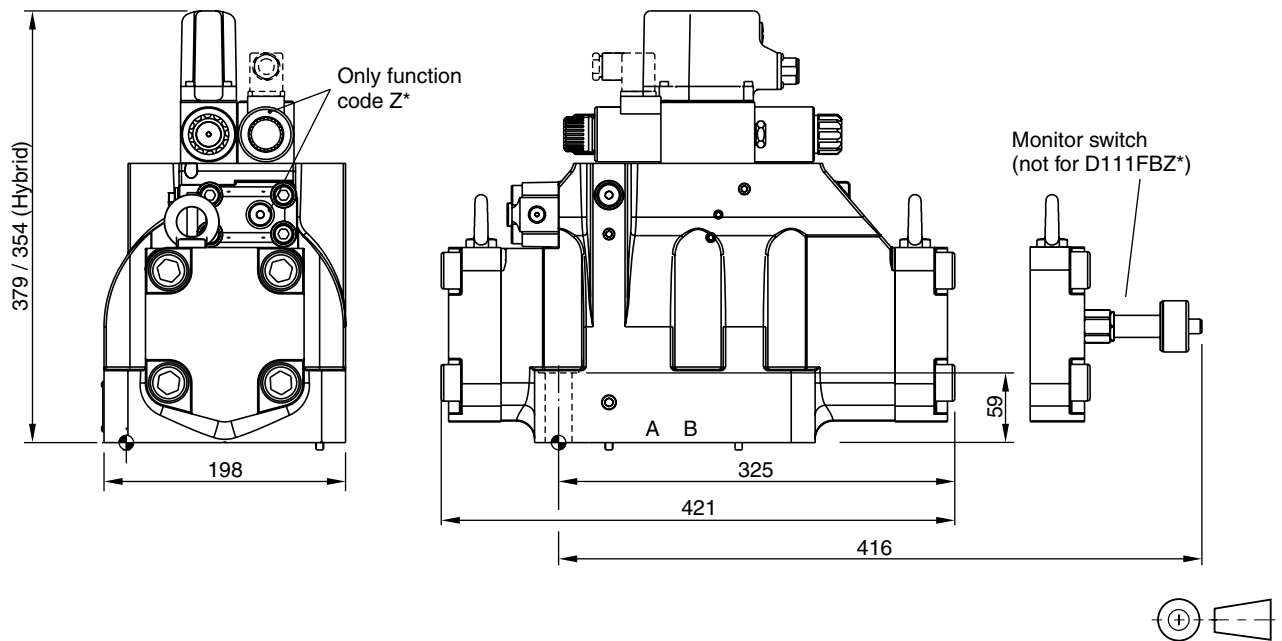

Surface finish	Kit	Kit	Kit	Kit
	BK386	6x M20x90 ISO 4762-12.9	517 Nm ±15 %	NBR: SK-D111FB FPM: SK-D111FB-V