

Parker Series D3FB Direct Operated Proportional Directional Control Valve Service Manual

A

General Description

Series D3FB (NG10) proportional directional valves are available with and without onboard electronics (OBE).

D3FB OBE:

The digital onboard electronics is situated in a robust metal housing, which allows the usage under rough environmental conditions.

The nominal values are factory set. The cable connection to a serial RS-232 interface is available as accessory.

D3FB for external electronics:

The parameters can be saved, changed and duplicated in combination with the digital power amplifier PWD00A-400.

The valve parameters can be edited with the common ProPxD software for both versions.

Series D3FB valves can be ordered with spool/sleeve design (D3FB*0) for maximum precision, as well as spool/body design (D3FB*3) for high nominal flow – see functional limit curves for maximum flow capability



D3FB



D3FB OBE

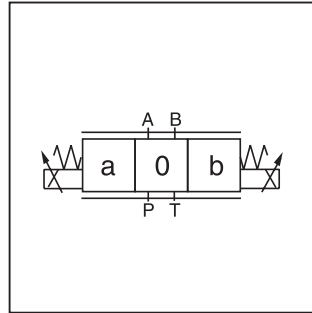

D3FB

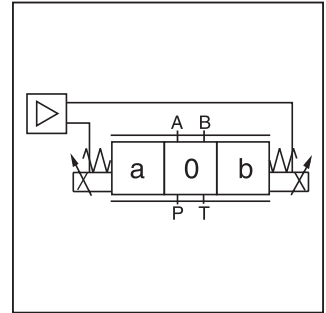

D3FB OBE



Features

- Spool/sleeve and spool/body
- 3 command options for D3FB OBE: +/- 10V, 4...20mA, +/- 20mA
- High repeatability from valve to valve
- Low hysteresis
- Manual override
- Digital onboard electronics

D3FB*0 OBE

Spool/Sleeve Design

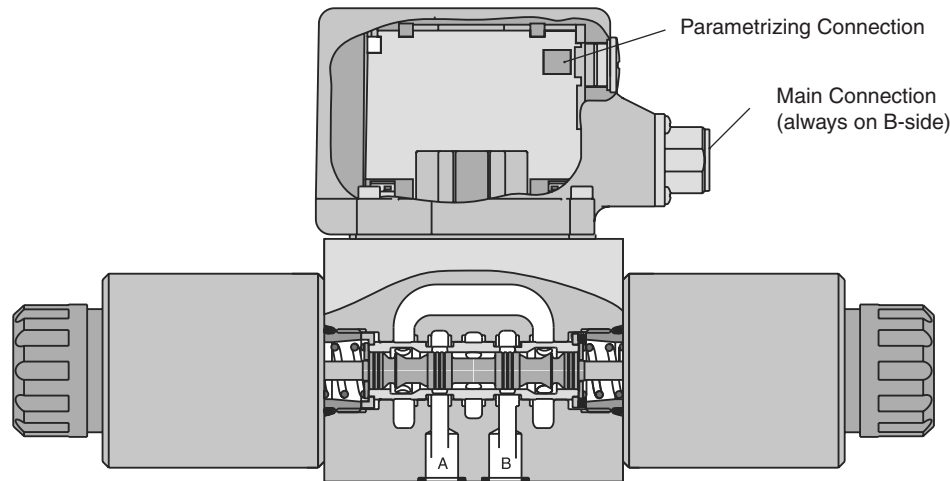

D3FB*3 OBE

Spool/Body Design

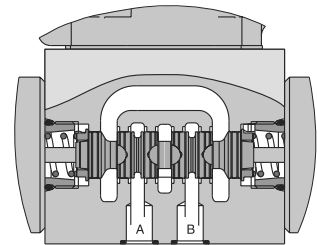

WARNING: This product can expose you to chemicals including Lead, Nickel (Metallic), or 1,3-Butadiene which are known to the State of California to cause cancer, and Lead or 1,3-Butadiene which is known to the State of California to cause birth defects and other reproductive harm. For more information go to www.P65Warnings.ca.gov.

A01_Cat2500.indd, ddp, 04/19



A

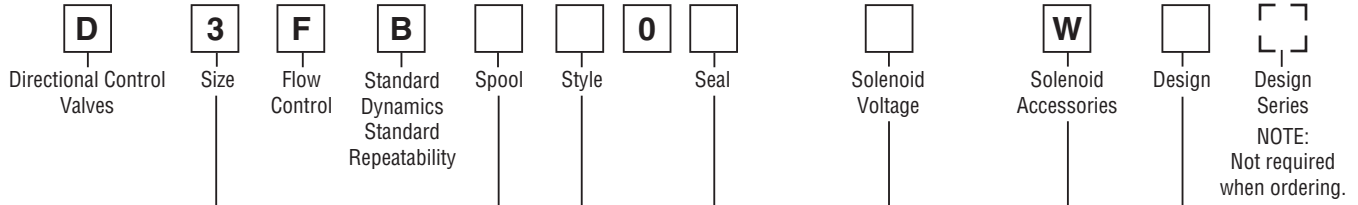

Code	Description
3	DIN NG10 CETOP 5 NFPA D05

D3FB*0: Spool/Sleeve Design	
Code	Solenoid
K	12V / 2.95A

D3FB*3: Spool/Body Design	
Code	Solenoid
K	12V / 2.95A
J	24V / 1.5A

Code	Description
0	Spool/sleeve design
3	Spool/body design

Code	Description
N	Nitrile
V	Fluorocarbon

Code	Description
W*	Connector as per DIN 43650 without plug

* Please order plugs separately.
See Accessories.

D3FB*0: Spool/Sleeve Design		
Code	Spool	Flow LPM (GPM) at Δp 5 Bar (72.5 PSI) per metering edge
E01M E01S		40 (10.6) 60 (15.9)
E02M E02S		40 (10.6) 60 (15.9)
B31M B31S	$Q_b = Q_a/2$ 	40 / 20 (10.6 / 5.3) 60 / 30 (15.9 / 7.9)
B32M B32S	$Q_b = Q_a/2$ 	40 / 20 (10.6 / 5.3) 60 / 30 (15.9 / 7.9)

D3FB*3: Spool/Body Design		
Code	Spool	Flow LPM (GPM) at Δp 5 Bar (72.5 PSI) per metering edge
E01M E01S E01U		40 (10.6) 60 (15.9) 80 (21.2)
E02M E02S E02U		40 (10.6) 60 (15.9) 80 (21.2)

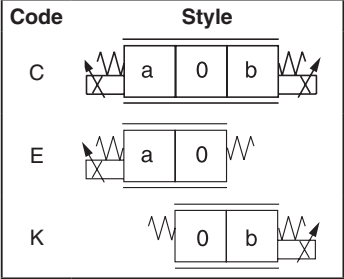

Bolt Kit:
 BK98 (4) 1/4-24x1.625 SHCS
 BK385 (4) M6x40

Weight:
 D3FB 6.5 kg (14.3 lbs.)



A

General		
Design	Direct operated proportional DC valve	
Actuation	Proportional solenoid	
Size	NG10 / CETOP 5 / NFPA D05	
Mounting Interface	DIN 24340 / ISO 4401 / CETOP RP121 / NFPA	
Mounting Position	Unrestricted	
Ambient Temperature	[°C]	-20...+60; (-4°F...+140°F)
MTTF _D Value (OBE)	[years]	150 (75)
Vibration Resistance	[g]	10 Sinus 5...2000 Hz acc. IEC 68-2-6 30 Random noise 20...2000 Hz acc. IEC 68-2-36 15 Shock acc. IEC 68-2-27
Hydraulic		
Maximum Operating Pressure	Ports P, A, B 350 Bar (5075 PSI); Port T 210 Bar (3045 PSI)	
Maximum Pressure Drop PABT / PBAT	350 Bar (5075 PSI)	
Fluid	Hydraulic oil as per DIN 51524...51535, other on request	
Fluid Temperature	[°C]	-20...+60; (-4°F...+140°F)
Viscosity		
Permitted	[cSt] / [mm ² /s]	20...380 (93...1761 SSU)
Recommended	[cSt] / [mm ² /s]	30...80 (139...371 SSU)
Filtration	ISO 4406 (1999) 18/16/13 (acc. NAS 1638: 7)	
Nominal Flow at Δp=5 Bar (72.5 PSI) per Control Edge *	D3FB*0 (Spool/sleeve)	D3FB*3 (Spool/body)
	40 LPM (10.6 GPM) / 60 LPM (15.9 GPM)	
Leakage at 100 Bar (1450 PSI)	[ml/min]	<100
Overlap	[%]	25, electrically normalized at 10 (see flow characteristics)
Static / Dynamic		
Step Response at 100% Step	[ms]	40
Hysteresis	[%]	<4
Temperature Drift Solenoid Current	[%/K]	<0.02
Electrical		
Duty Ratio	[%]	100 ED; CAUTION: Coil temperature up to 150°C (302°F) possible
Protection Class	IP65 in accordance with EN60529 (plugged and mounted)	
Solenoid	Code "K"	Code "J"
Supply Voltage	[V]	12
Current Consumption	[A]	2.95
Resistance	[Ohm]	3.84
Solenoid Connection	Connector as per EN 175301-803	
Wiring Minimum	[mm ²]	3x1.5 recommended
Wiring Length Maximum	[m]	50 (164 ft.)

* Flow rate for different Δp per control edge: $Q_x = Q_{Nom.} \cdot \sqrt{\frac{\Delta p_x}{\Delta p_{Nom.}}}$

Continued on the next page

(Electrically set to opening point 10%)

A

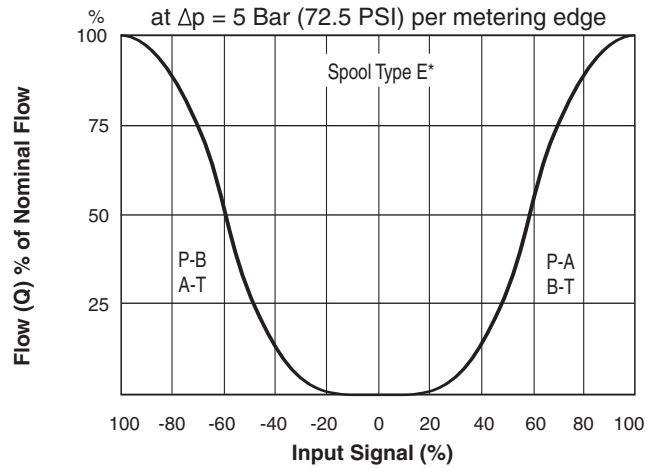
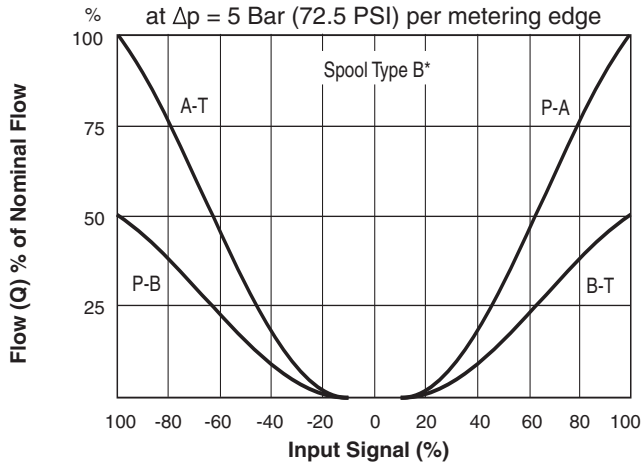

All performance curves measured with HLP46 at 50°C (122°F).

Functional Limits

100% command signal (symmetric flow). At asymmetric flow a reduced flow limit has to be considered – typically approx. 10% lower.

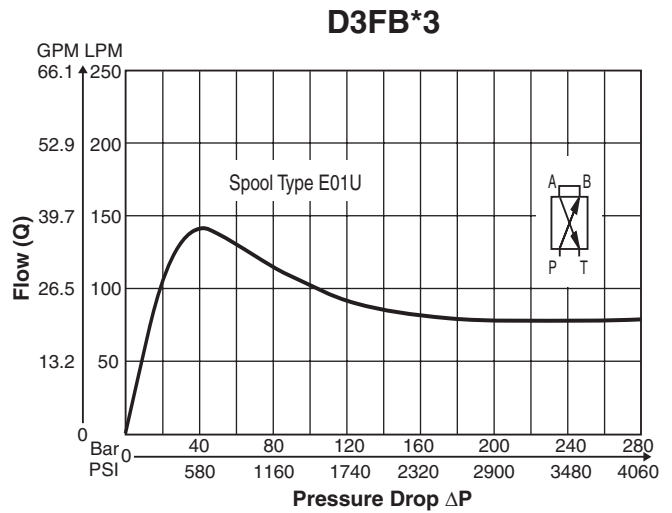
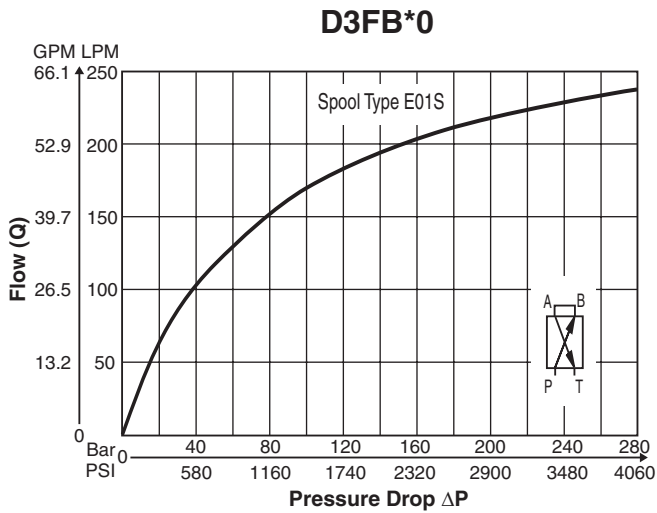

All performance curves measured with HLP46 at 50°C (122°F).

Block Diagrams — Wiring

Code F0

6 + PE acc. to EN 175201-804

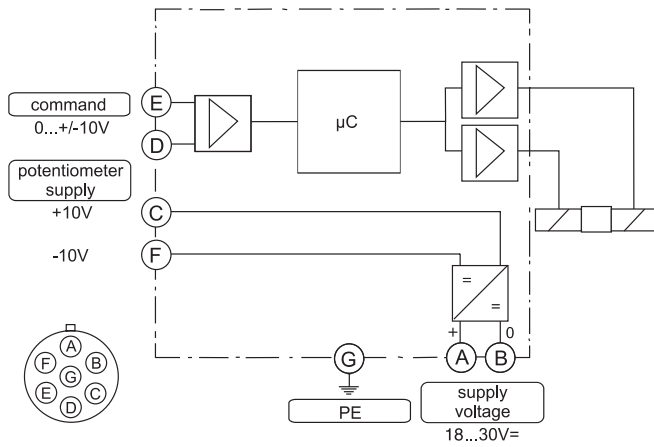

Code G0, S0

6 + PE acc. to EN 175201-804

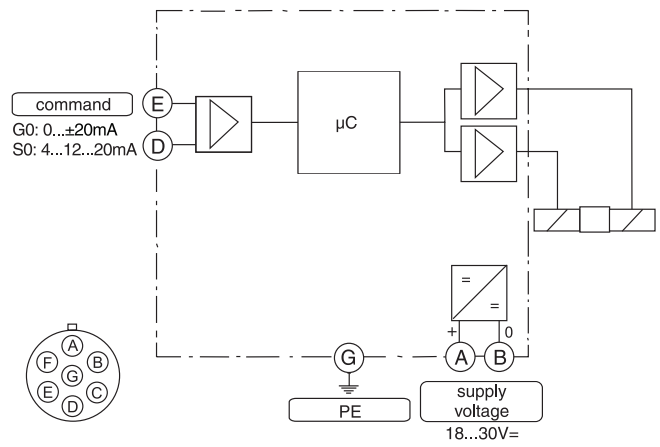

Code W5

11 + PE acc. to EN 175201-804

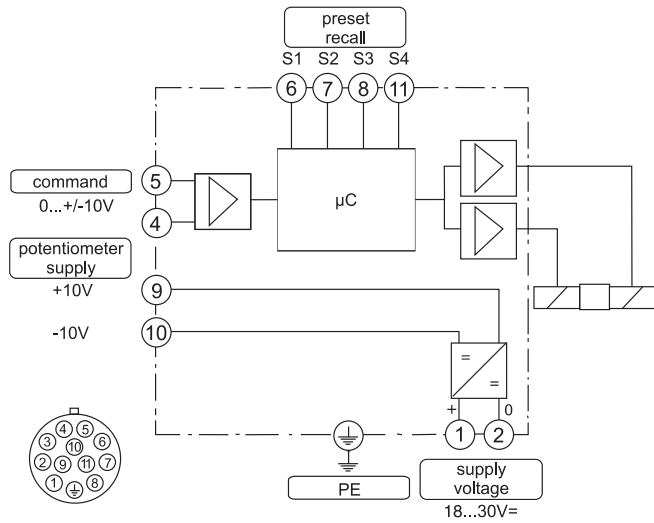

A

ProPxD Interface Program

A

The ProPxD software allows quick and easy setting of the digital valve electronics. Individual parameters as well as complete settings can be viewed, changed and saved via the comfortable user interface. Parameter sets saved in the non-volatile memory can be loaded to other valves of the same type or printed out for documentation purposes.

Features

- Simple editing of all parameters.
- Storage and loading of optimized parameter adjustments.
- Executable with all Windows® operating systems from Windows® 95 upwards.
- Communication between PC and electronics via serial interface RS-232.

The valve electronics cannot be connected to a PC with a standard USB cable – this can result in damages of PC and/or valve electronics.

Simple to use interface program. Download free of charge www.parker.com/propxd

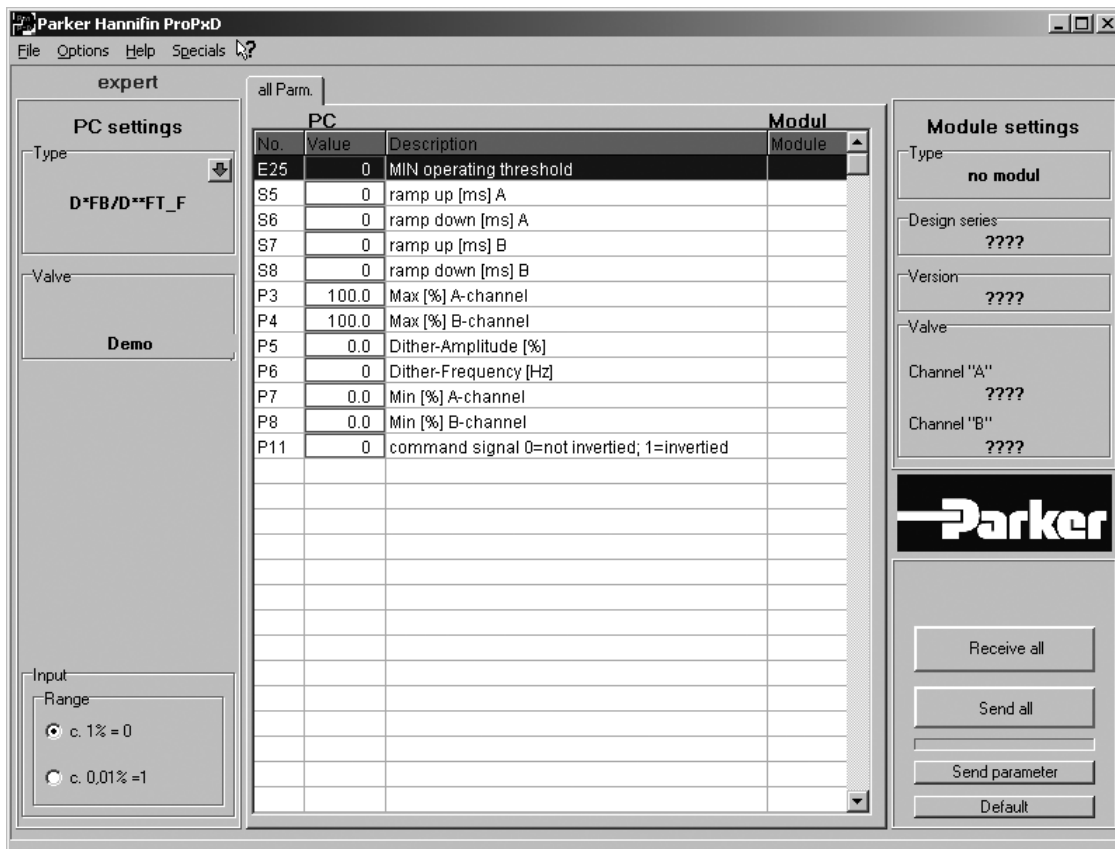

The parametrizing cable may be ordered under item no. 40982923.

Inch equivalents for millimeter dimensions are shown in (**)

D3FB*C

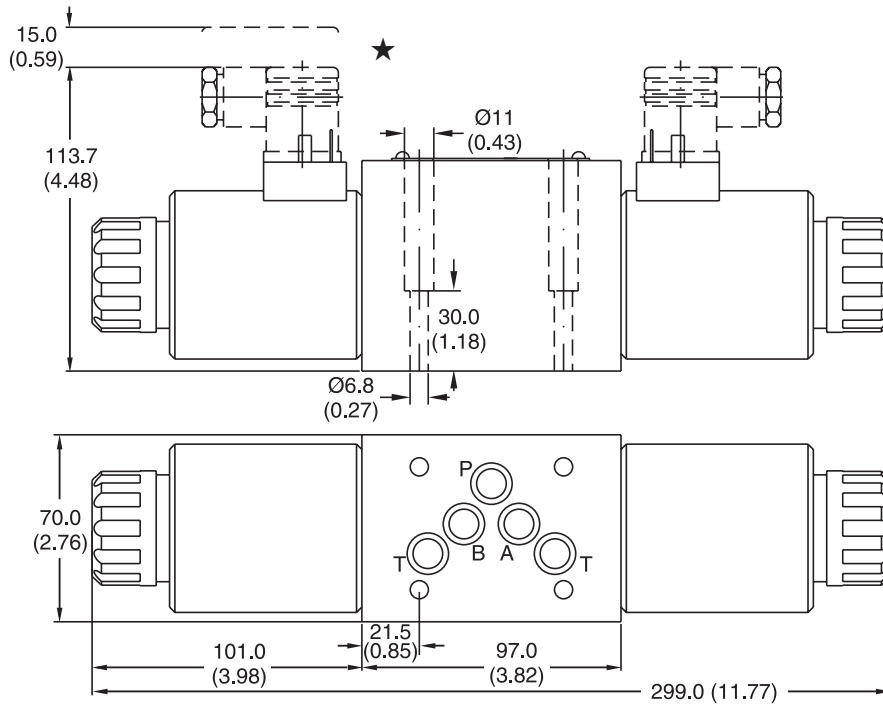

D3FB*K

★ Order plugs separately.

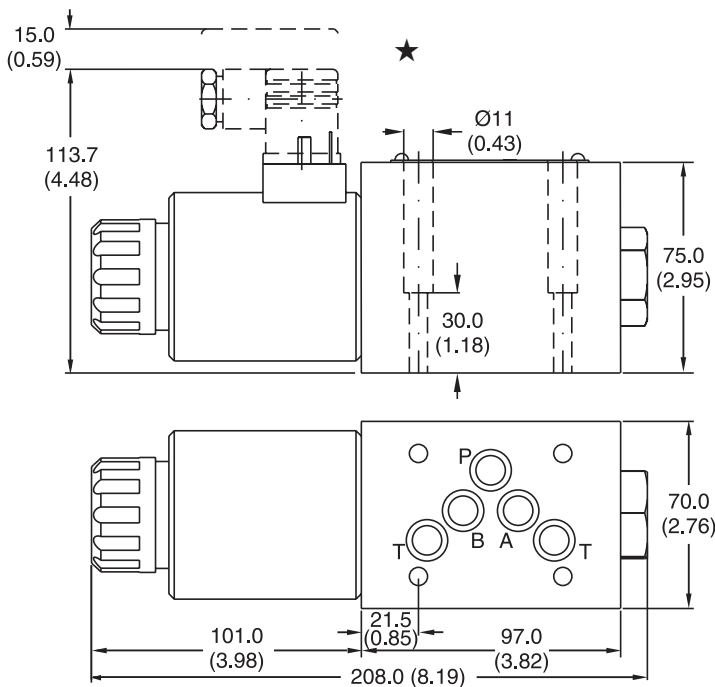

Surface Finish	Kit	Kit	Kit	Seal Kit
	BK385	4x M6x40 DIN 912 12.9	13.2 Nm (9.7 lb.-ft.) ±15 %	Nitrile: SK-D3FB Fluorocarbon: SK-D3FBV
	BK98	4x 1/4-20x1.62		