

Parker Series EVSA Direct Operated Pressure Relief Valve Service Manual

The direct operated pressure relief valve series EVSA is a seated type valve for screw-in mounting. It is available in two sizes and three pressure stages.

Function

When the pressure in port P exceeds the setting pressure the cone opens to port T and thus limits the pressure in port P to the adjusted level.

The integrated damping spool prevents pressure fluctuations in the transition region. The pressure is set by the adjusting screw, which is locked by the clamping screw. The setting can optionally be secured by a cylinder lock.

Features

- Seated type valve
- Screw-in mounting
- 3 pressure stages
- 2 adjustment modes:
 - screw with hexagon socket
 - cylinder lock

Note

The spring must be unloaded when the EVSA is screwed out of the manifold.

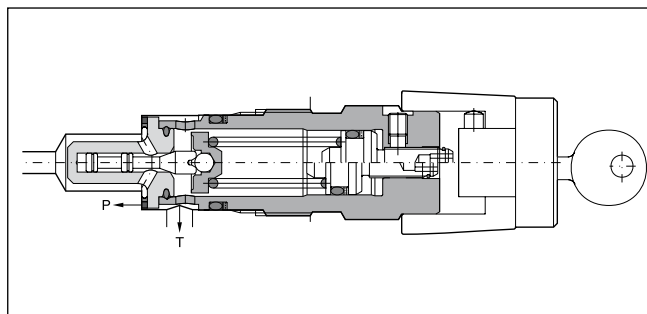
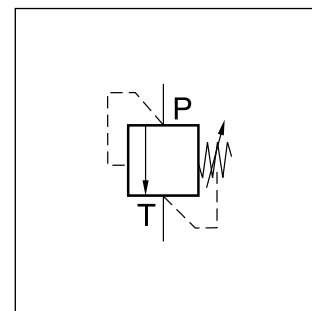

4

Ordering code

EVSA

Pressure relief valve

□

Pressure stages

A

Adjustment screw with hex. socket

□

Nominal size / thread type

1

FPM Seals

□

Design series (not required for ordering)

□

Lock

Code	Pressure stages
064	up to 64 bar
160	up to 160 bar
315	up to 315 bar

Code	Lock
omit	–
Z	Cylinder lock

Code	Nominal size
06	NG06, M28x1.5
10	NG10, M35x1.5

Bold letters = Short-term availability

Technical data

General		
Design	Direct operated relief valve, seated type	
Nominal size	NG06	NG10
Interface	Screw-in mounting	
Mounting position	unrestricted	
Ambient temperature	[°C]	-20...+60
MTTF _D value	[years]	150
Weight	[kg]	0.3
		0.45
Hydraulics		
Max. operating pressure	[bar]	Port P 315, Port T depressurized
Pressure stages	[bar]	64, 160, 315
Nominal flow	[l/min]	40 (NG06), 80 (NG10)
Fluid	Hydraulic oil according to DIN 51524	
Fluid temperature	[°C]	-20...+70
Viscosity permitted	[cSt] / [mm²/s]	20...400
recommended	[cSt] / [mm²/s]	30...80
Filtration	ISO 4406 (1999); 18/16/13	

$\Delta p/Q$ performance curves

NG06 pressure stage 64 bar

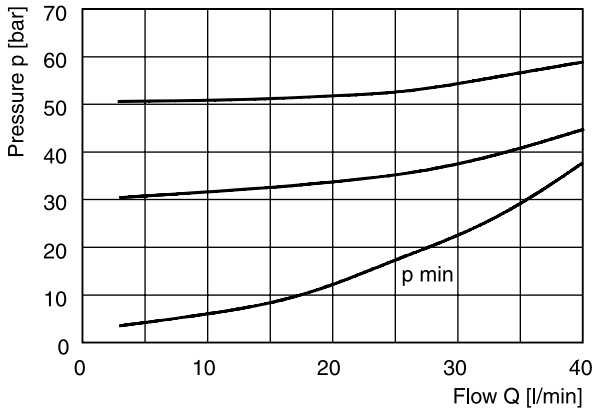

NG10 pressure stage 64 bar

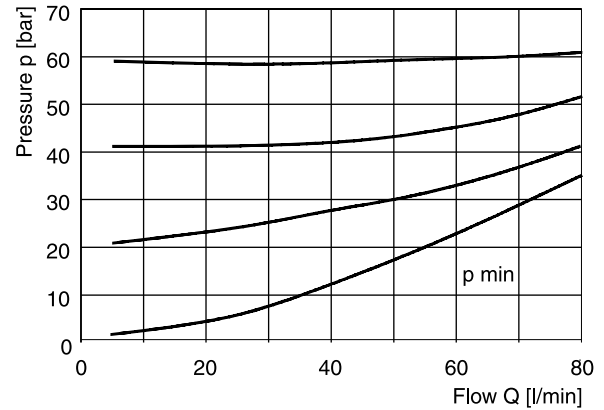

NG06 pressure stage 160 bar

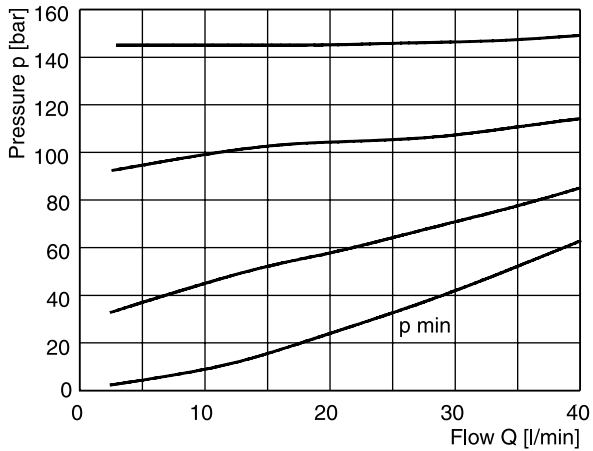

NG10 pressure stage 160 bar

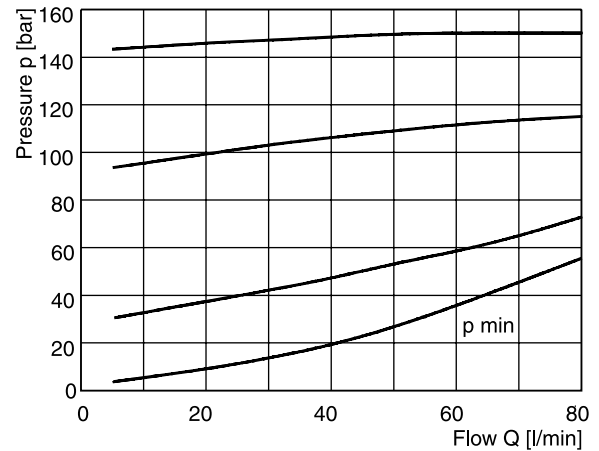

NG06 pressure stage 315 bar

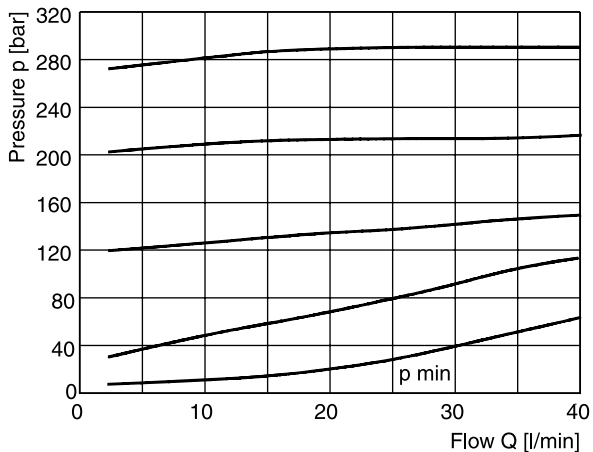

NG10 pressure stage 315 bar

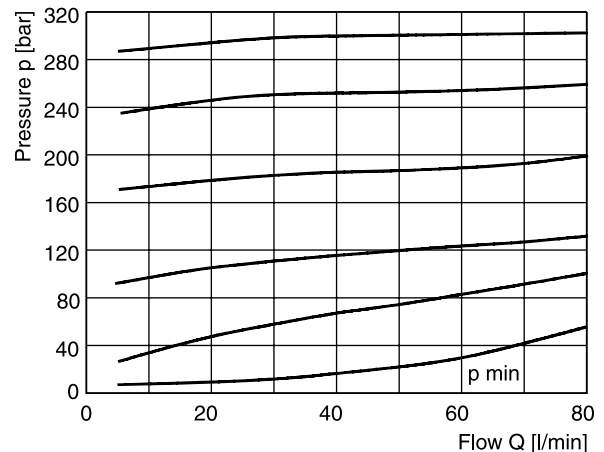

All characteristic curves measured with HLP46 at 50 °C.

4

Dimensions

NG06

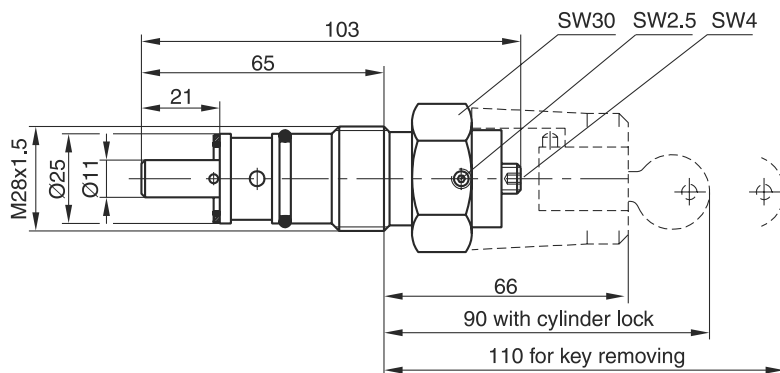

○ Kit
SK-EVSAA0613

NG10

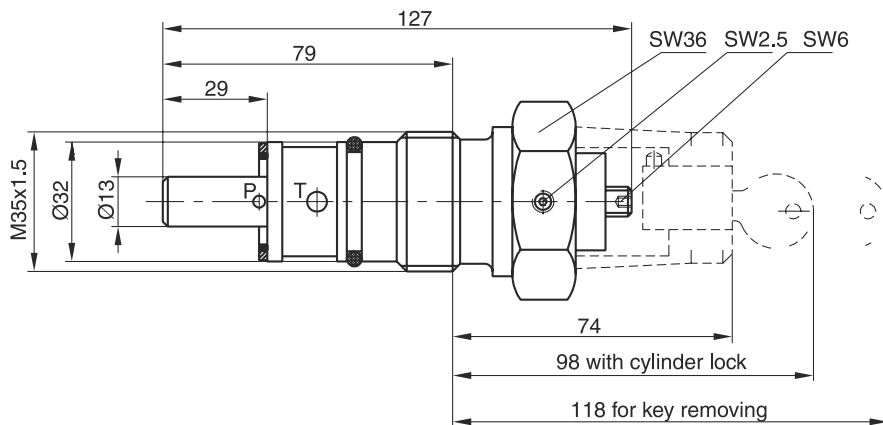

○ Kit
SK-EVSAA1013

Installation dimensions

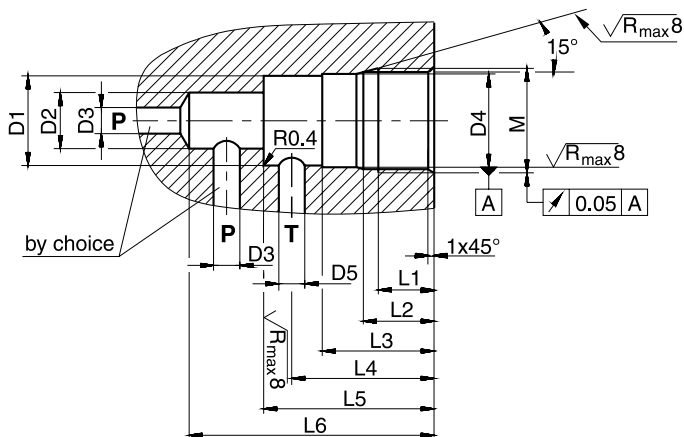

Tightening torque [Nm] ±5 %		
Pressure stages	NG06	NG10
064, 160	50	100
315	80	150

Size	M	D ₁	D ₂	D ₃	D ₄	D ₅	L ₁	L ₂	L ₃	L ₄	L ₅	L ₆
NG06	M28 x 1.5	Ø24.8	Ø15	Ø6.8	Ø25 ^{H9}	Ø6.8	15	19	30	35	45	65
NG10	M35 x 1.5	Ø31.8	Ø18.5	Ø10	Ø32 ^{H9}	Ø10	18	23	35	41 - 46	52	80