

Parker Series R4R Pilot Operated Pressure Reducing Valve, Subplate Mounting Service Manual

General Description

Series R4R pressure reducing valves are used to control the pressure in the secondary part of the hydraulic system. Independent of the primary pressure the secondary pressure is reduced to the pressure setting. In order to avoid undesired motion the valves are normally closed.

Specifications

Size	NG10, NG25, NG32
Interface	Subplate mounting acc. ISO 5781
Mounting Pos.	As desired, horizontal mounting preferred
Ambient Temp.	-20°C to +80°C (-4°F to +176°F)
Max. Oper. Pressure	Ports A, B and X: 350 Bar (5075 PSI), Port Y: depressurized
Pressure Range	up to 105, 210, 350 Bar (1523, 3045, 5075 PSI)
Nominal Flow	Size NG10: 150 LPM (39.7 GPM) Size NG25: 350 LPM (92.6 GPM) Size NG32: 500 LPM (132.3 GPM)
Pressure Fluid	Hydraulic oil according to DIN 51524... 51525
Pressure Fluid Temperature	Recommended: +30°C to +50°C (86°F to +122°F) Maximum: -20°C to +70°C (-4°F to +158°F)
Viscosity	Recommended: 30 to 50 cSt (mm ² /s) Maximum: 20 to 380 cSt (mm ² /s)
Filtration	ISO 4406 (1999), 18/16/13

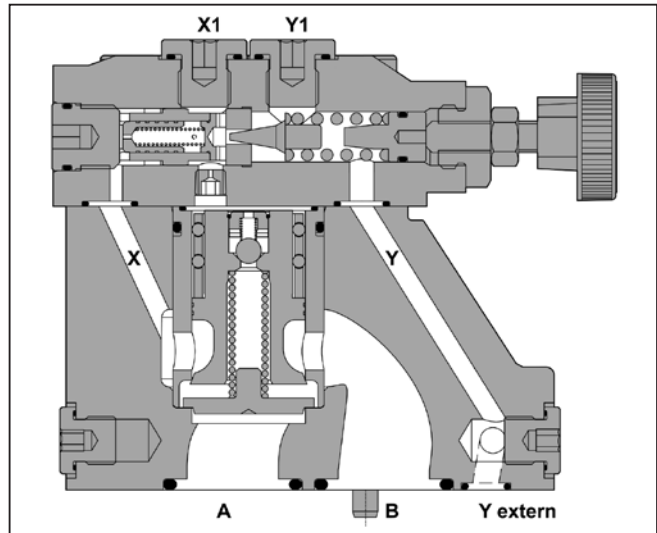
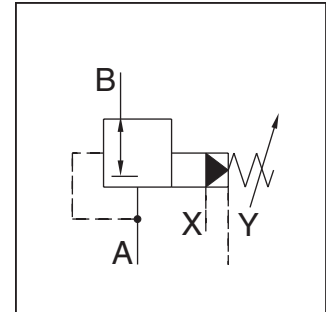

Features

- Subplate mounting acc. to ISO 5781.
- Normally closed to avoid unintended motion.
- 3 pressure ranges.
- Three adjustment modes:
 - Hand knob
 - Acorn nut with lead seal
 - Key lock

Ordering Information

R	4	R	□	—	5	7	□	□	□	B	□	□																					
Pressure Reducing Valve	Interface	Reducing Function	Size	—	Maximum Pressure 350 Bar (5075 PSI)	Body Mounting	Pressure Range	Adjustment	Pilot Oil	Design Series	Seal	Options Check with Factory																					
	<table border="1"> <thead> <tr> <th>Code</th> <th>Description</th> </tr> </thead> <tbody> <tr> <td>03</td> <td>NG10</td> </tr> <tr> <td>06</td> <td>NG25</td> </tr> <tr> <td>10</td> <td>NG32</td> </tr> </tbody> </table> <p style="font-size: small;">Mounting: Subplate mounting</p>	Code	Description	03	NG10	06	NG25	10	NG32				<table border="1"> <thead> <tr> <th>Code</th> <th>Description</th> </tr> </thead> <tbody> <tr> <td>1</td> <td>up to 105 Bar (1523 PSI)</td> </tr> <tr> <td>3</td> <td>up to 210 Bar (3045 PSI)</td> </tr> <tr> <td>5</td> <td>up to 350 Bar (5075 PSI)</td> </tr> </tbody> </table>	Code	Description	1	up to 105 Bar (1523 PSI)	3	up to 210 Bar (3045 PSI)	5	up to 350 Bar (5075 PSI)				<table border="1"> <thead> <tr> <th>Code</th> <th>Description</th> </tr> </thead> <tbody> <tr> <td>1</td> <td>Nitrile</td> </tr> <tr> <td>5</td> <td>Fluorocarbon</td> </tr> </tbody> </table>	Code	Description	1	Nitrile	5	Fluorocarbon		
Code	Description																																
03	NG10																																
06	NG25																																
10	NG32																																
Code	Description																																
1	up to 105 Bar (1523 PSI)																																
3	up to 210 Bar (3045 PSI)																																
5	up to 350 Bar (5075 PSI)																																
Code	Description																																
1	Nitrile																																
5	Fluorocarbon																																
<table border="1"> <thead> <tr> <th>Code</th> <th>Interface</th> </tr> </thead> <tbody> <tr> <td>4</td> <td>Subplate Mounting ISO 5781</td> </tr> </tbody> </table>	Code	Interface	4	Subplate Mounting ISO 5781		<table border="1"> <thead> <tr> <th>Code</th> <th>Description</th> </tr> </thead> <tbody> <tr> <td>1</td> <td>Hand Knob 32mm dia. Std.</td> </tr> <tr> <td>3</td> <td>Acorn Nut with Lead Seal</td> </tr> <tr> <td>4</td> <td>Key Lock</td> </tr> </tbody> </table>	Code	Description	1	Hand Knob 32mm dia. Std.	3	Acorn Nut with Lead Seal	4	Key Lock	<table border="1"> <thead> <tr> <th>Code</th> <th>Description</th> <th>Pilot</th> <th>Drain</th> </tr> </thead> <tbody> <tr> <td>1</td> <td>Internal</td> <td>Internal</td> <td>External from Y</td> </tr> <tr> <td>2</td> <td>Internal</td> <td>Internal</td> <td>External from Y1</td> </tr> </tbody> </table> <p>Weight:</p> <p>R4R03: 4.8 kg (10.6 lbs.) R4R06: 7.2 kg (15.9 lbs.) R4R10: 13.5 kg (29.8 lbs.)</p>	Code	Description	Pilot	Drain	1	Internal	Internal	External from Y	2	Internal	Internal	External from Y1						
Code	Interface																																
4	Subplate Mounting ISO 5781																																
Code	Description																																
1	Hand Knob 32mm dia. Std.																																
3	Acorn Nut with Lead Seal																																
4	Key Lock																																
Code	Description	Pilot	Drain																														
1	Internal	Internal	External from Y																														
2	Internal	Internal	External from Y1																														

R4R.indd, dd

R4R03 1)

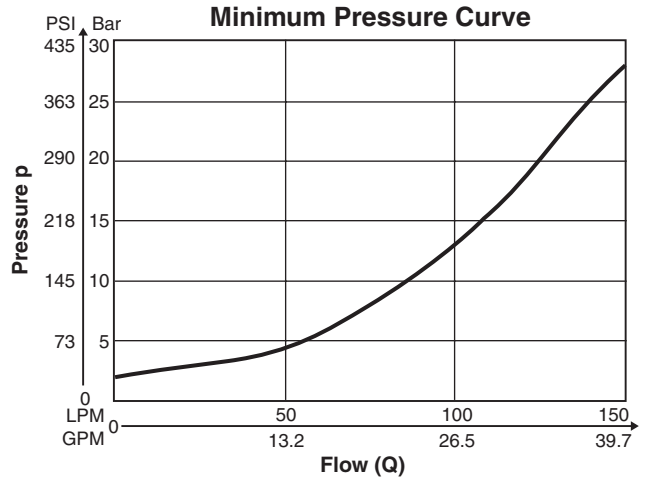
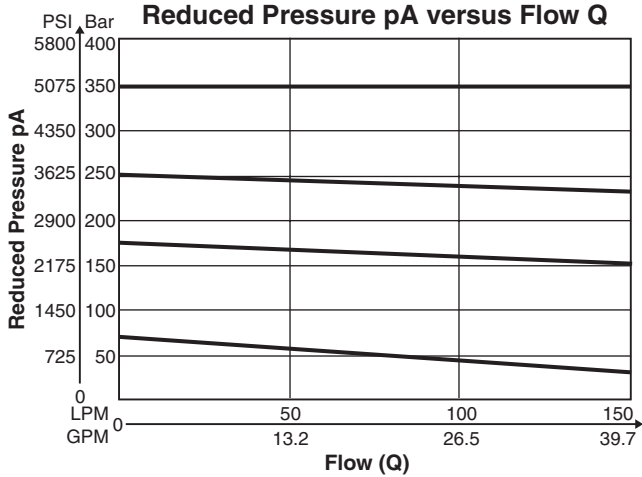

R4R06 1)

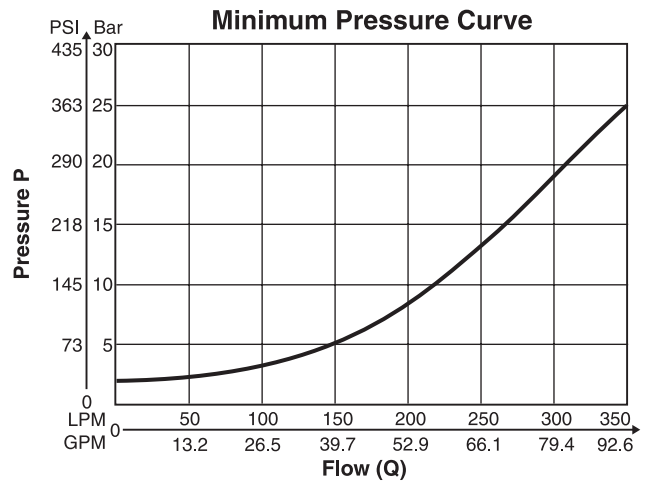
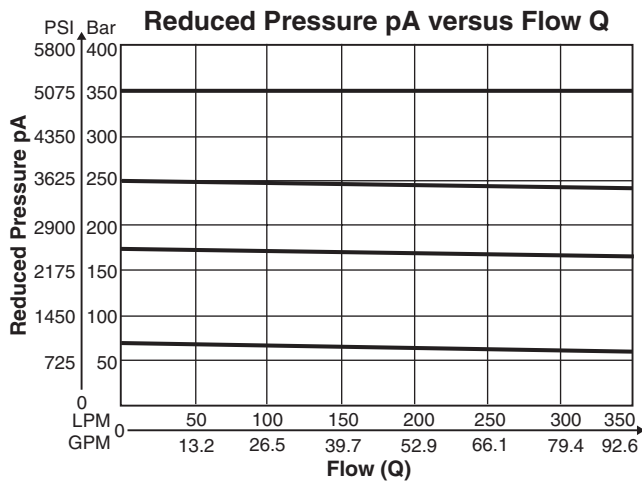

R4R10 1)

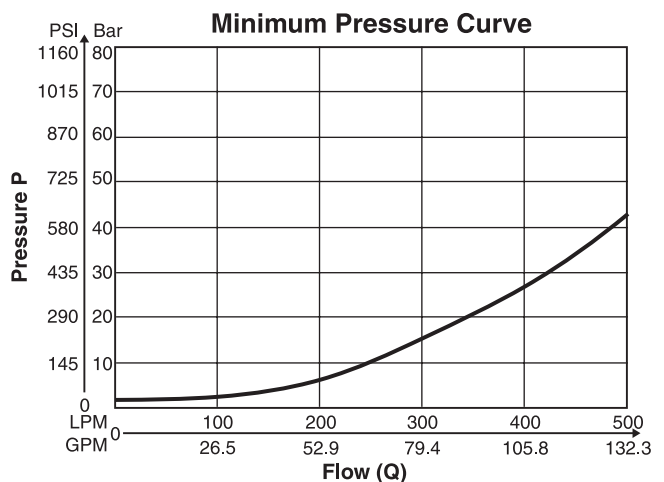
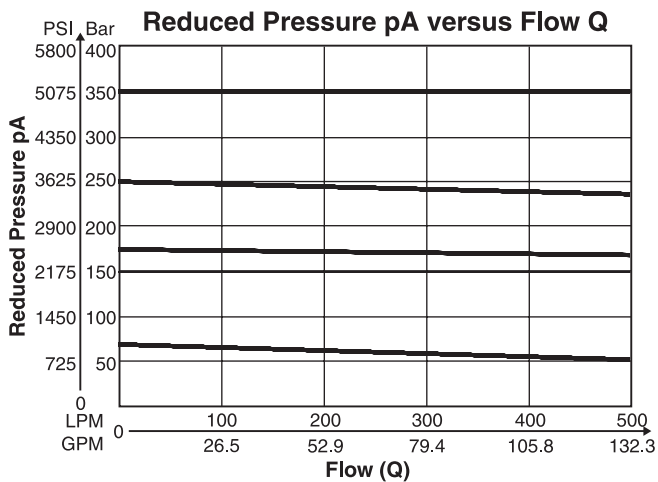

¹⁾ Measured at 350 Bar (5075 PSI) primary pressure pB.



D

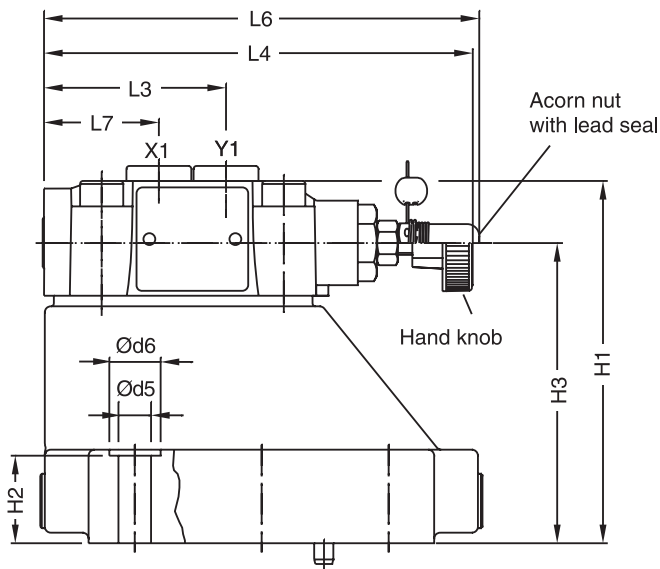
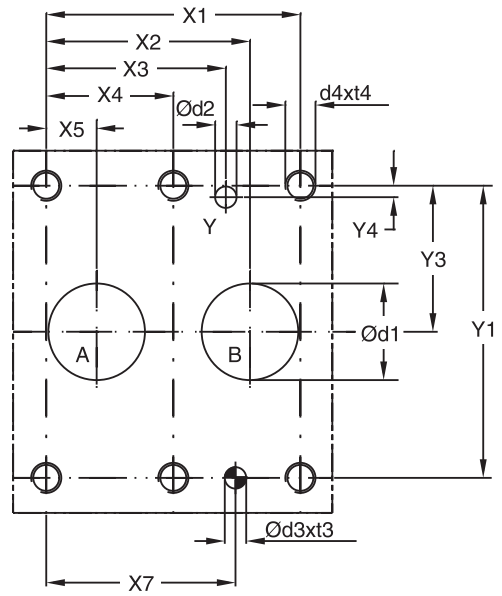
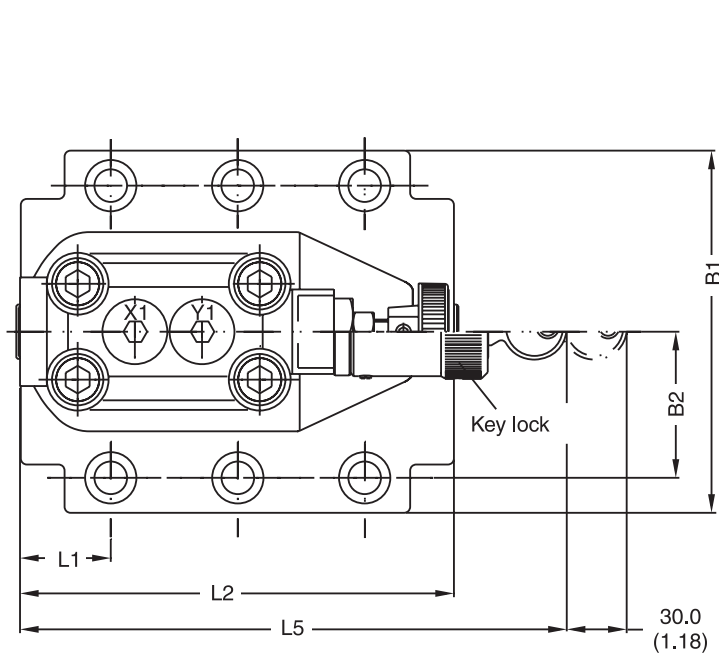



Inch equivalents for millimeter dimensions are shown in (**)

NG	ISO-code	x1	x2	x3	x4	x5	x6	x7	y1	y2	y3	y4	y5	y6
10	5781-06-07-0-00	42.9 (1.69)	35.8 (1.41)	21.5 (0.85)	— —	7.2 (0.28)	— —	31.8 (1.25)	66.7 (2.63)	— —	33.4 (1.31)	7.9 (0.31)	— —	— —
25	5781-08-10-0-00	60.3 (2.37)	49.2 (1.94)	39.7 (1.56)	— —	11.1 (0.44)	— —	44.5 (1.75)	79.4 (3.13)	— —	39.7 (1.56)	6.4 (0.25)	— —	— —
32	5781-10-13-0-00	84.2 (3.31)	67.5 (2.66)	59.5 (2.34)	42.1 (1.66)	16.7 (0.66)	— —	62.7 (2.47)	96.8 (3.81)	— —	48.4 (1.92)	3.8 (0.15)	— —	— —

Tolerance for all dimensions ±0.2

NG	ISO-code	B1	B2	H1	H2	H3	H4	H5	H6	L1	L2	L3	L4	L5	L7
10	5781-06-07-0-00	87.3 (3.44)	33.4 (1.31)	83.0 (3.27)	21.0 (0.83)	62.5 (2.46)	— —	— —	— —	29.0 (1.14)	94.8 (3.73)	60.8 (2.39)	141.0 (5.55)	181.0 (7.13)	38.6 (1.52)
25	5781-08-10-0-00	105.0 (4.13)	39.7 (1.56)	109.5 (4.31)	29.0 (1.14)	89.0 (3.50)	— —	— —	— —	34.7 (1.37)	126.8 (4.99)	60.8 (2.39)	141.0 (5.55)	181.0 (7.13)	38.6 (1.52)
32	5781-10-13-0-00	120.0 (4.72)	48.4 (1.91)	120.0 (4.72)	29.0 (1.14)	99.5 (3.92)	— —	— —	— —	30.6 (1.20)	144.3 (5.68)	60.8 (2.39)	141.0 (5.55)	181.0 (7.13)	38.6 (1.52)

NG	ISO-code	d1max	d2max	d3	t3	d4	t4	d5	d6
10	5781-06-07-0-00	15.0 (0.59)	7.0 (0.28)	7.1 (0.28)	8.0 (0.31)	M10	16.0 (0.63)	10.8 (0.43)	17.0 (0.67)
25	5781-08-10-0-00	23.4 (0.92)	7.1 (0.28)	7.1 (0.28)	8.0 (0.31)	M10	18.0 (0.71)	10.8 (0.43)	17.0 (0.67)
32	5781-10-13-0-00	32.0 (1.26)	7.1 (0.28)	7.1 (0.28)	8.0 (0.31)	M10	20.0 (0.79)	10.8 (0.43)	17.0 (0.67)

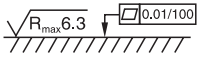
NG	ISO-code	Bolt Kit			Seal Nitrile	Kit Fluorocarbon	Surface Finish
10	5781-06-07-0-00	BK505	4xM10 x 35-DIN 912 12.9	63 Nm (46.5 lb.-ft.) ±15%	S26-58507-0	S26-58507-5	
25	5781-08-10-0-00	BK485	4xM10 x 45-DIN 912 12.9	63 Nm (46.5 lb.-ft.) ±15%	S26-58475-0	S26-58475-5	
32	5781-10-13-0-00	BK506	6xM10 x 45-DIN 912 12.9	63 Nm (46.5 lb.-ft.) ±15%	S26-58508-0	S26-58508-5	

NG	ISO-code	Subplate	Size
10	5781-06-07-0-00	SPP3M6B910	A, B = 3/4" BSPP x, y = 1/4" BSPP
25	5781-08-10-0-00	SPP6M8B910	A, B = 1" BSPP x, y = 1/4" BSPP
32	5781-10-13-0-00	SPP10M12B910	A, B = 1 1/2" BSPP x, y = 1/4" BSPP

