

Parker Series R4RP2 Pilot Operated Pressure Reducing Valve, In-line Mounting Service Manual

B

General Description

Series R4R*P2 proportional pressure reducing valves are based on the mechanically adjusted Series R4R. The additional proportional unit between the mechanical pilot valve and the main stage allows continuous pressure adjustment.

The optimum performance can be achieved in combination with the digital amplifier module PCD00A-400.

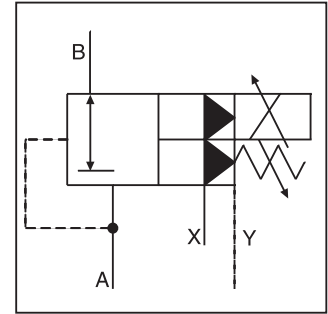

Features

- Pilot operated with proportional solenoid
- Normally closed to avoid undesired motion
- Continuous adjustment by proportional solenoid
- 2 interfaces:
 - L-body (R4R06-G3/4", R4R10-G1-1/4")
 - BSPP – T-body (R4R03-G1/2", R4R06-G1")
 - BSPP
- 4 sizes (SAE 1/2", 3/4", 1", 1-1/4")
- 3 pressure ranges
- With mechanical maximum pressure adjustment

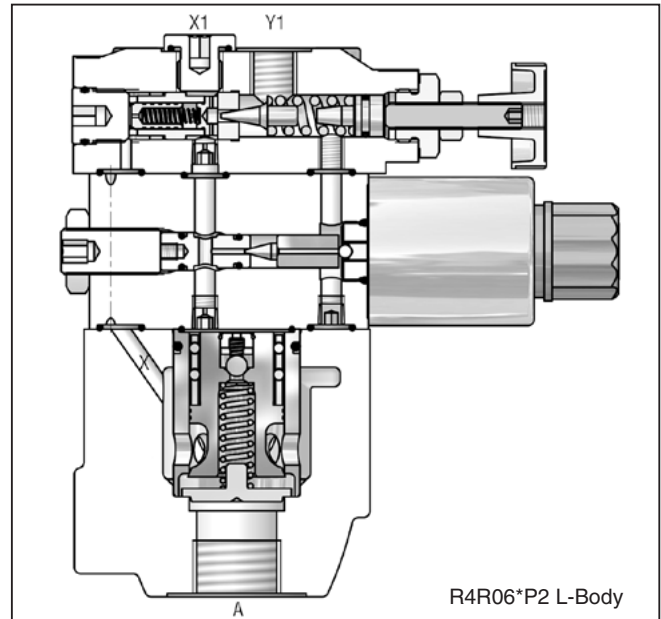

Ordering Information

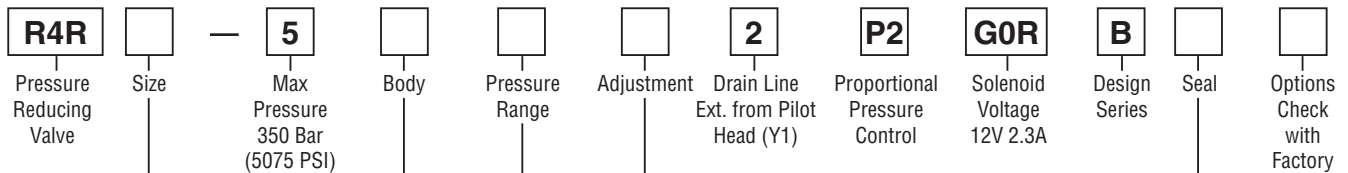

Code	Description
03	NG10 (G1/2")
06	NG25 (G1" – T-Body) (G3/4" – L-Body)
10	NG32 (G1-1/4")

Code	Description
1	Hand Knob
3	Acorn Nut with Lead Seal

Code	Description
1	Nitrile
5	Fluorocarbon

Code	Description
6	R4R03 T-Body R4R06 T-Body
D	R4R06 L-Body R4R10 L-Body

Code	Description
1	up to 105 Bar (1523 PSI)
3	up to 210 Bar (3045 PSI)
5	up to 350 Bar (5075 PSI)

Bolt Kits:

- R4R03: BK505 (4) M10x35
- R4R06: BK485 (4) M10x45
- R4R10: BK506 (6) M10x45

Weight:

- R4R03*P2: 5.0 kg (11.0 lbs.)
- R4R06*6*P2: 5.1 kg (11.2 lbs.)
- R4R06*D*P2: 7.4 kg (16.3 lbs.)
- R4R10*P2: 8.4 kg (18.5 lbs.)

WARNING: This product can expose you to chemicals including Lead, Nickel (Metallic), or 1,3-Butadiene which are known to the State of California to cause cancer, and Lead or 1,3-Butadiene which is known to the State of California to cause birth defects and other reproductive harm. For more information go to www.P65Warnings.ca.gov.

B01_Cat2550.indd, ddp, 04/19



Specifications

General				
Size	T-Body		L-Body	
	03 (1/2")	06 (1")	06 (3/4")	10 (1-1/4")
Mounting	Threaded Body			
Mounting Position	Unrestricted			
Ambient Temperature Range	-20°C to +50°C (-4°F to +122°F)			
MTTF _D Value	75 years			
Hydraulic				
Max. Operating Pressure	Ports A, B and X 350 Bar (5075 PSI); Port Y depressurized			
Pressure Ranges	105 Bar (1523 PSI), 210 Bar (3045 PSI), 350 Bar (5075 PSI)			
Nominal Flow	60 LPM (15.9 GPM)	200 LPM (52.9 GPM)	200 LPM (52.9 GPM)	450 LPM (119.0 GPM)
Fluid	Hydraulic oil as per DIN 51524...51535, other on request			
Fluid Temperature	-20°C to +80°C (-4°F to +176°F)			
Viscosity	Permitted 10 to 380 cSt / mm ² /s (46 to 1761 SSU)			
	Recommended 30 to 80 cSt / mm ² /s (139 to 371 SSU)			
Filtration	ISO Class 4406 (1999) 18/16/13 (acc. NAS 1638: 7)			
Electrical (Proportional Solenoid)				
Duty Ratio	100% ED; CAUTION: Coil temperature up to 150°C (302°F) possible			
Nominal Voltage	12 VDC			
Maximum Current	2.3 amps			
Coil Resistance	4 Ohm at 20°C (68°F)			
Solenoid Connection	Connector as per EN175301-803, Solenoid identification as per ISO9461			
Protection Class	IP65 in accordance with EN60529 (plugged and mounted)			
Power Amplifier	PCD00A-400			

Performance Curves

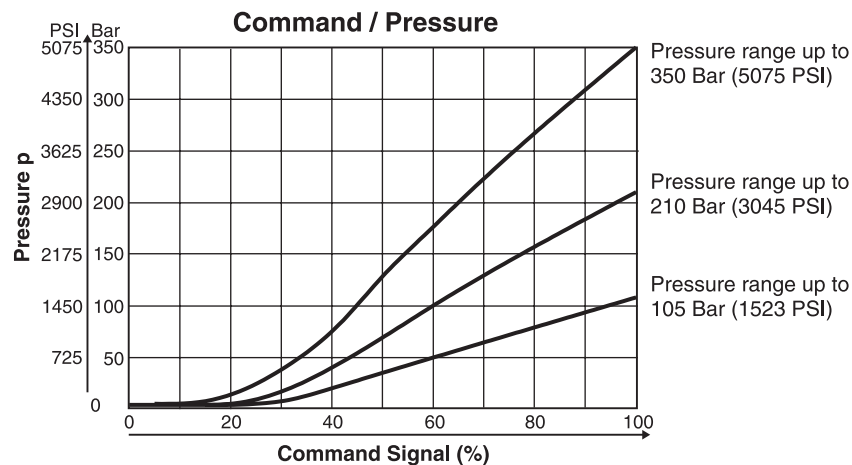

Performance Curves

R4R03*P2 ¹⁾

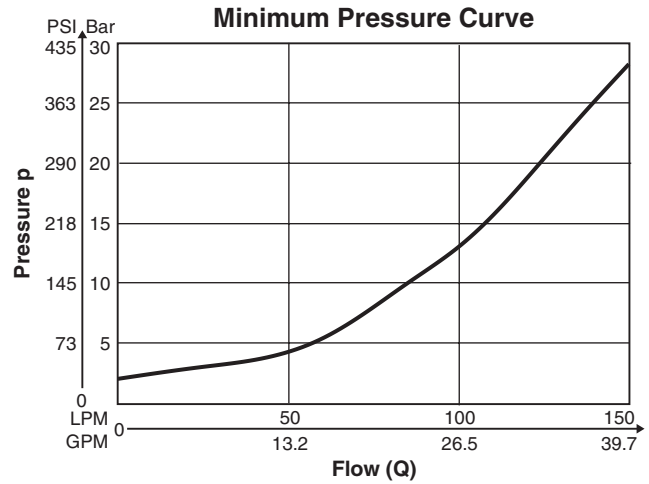
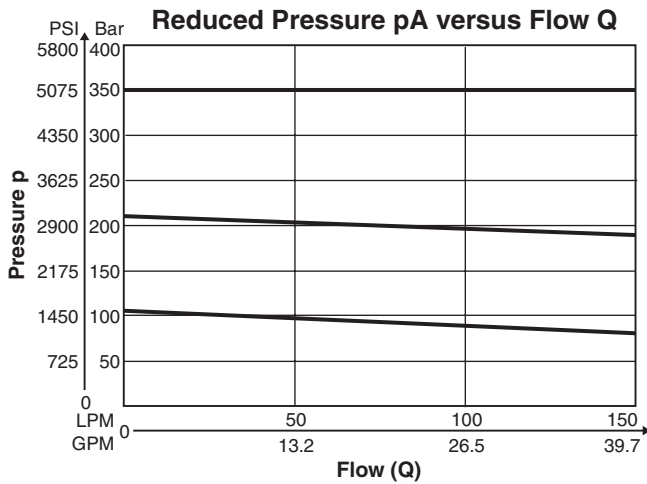

R4R06*P2 ¹⁾

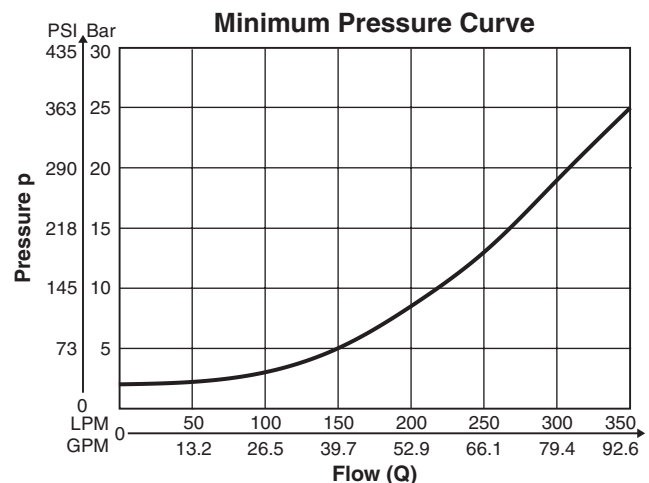
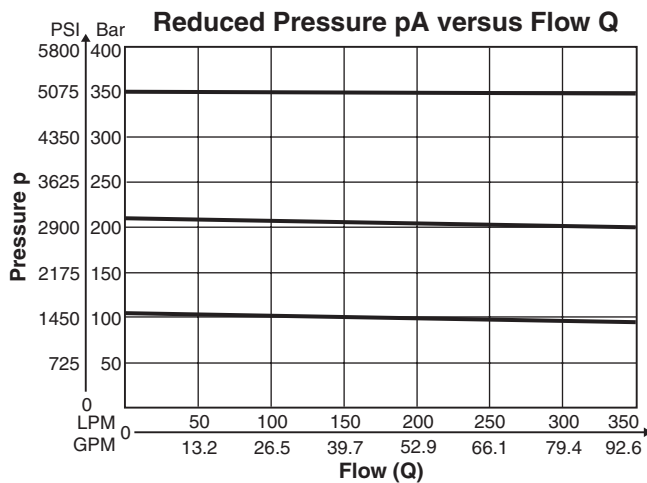

R4R10*P2 ¹⁾

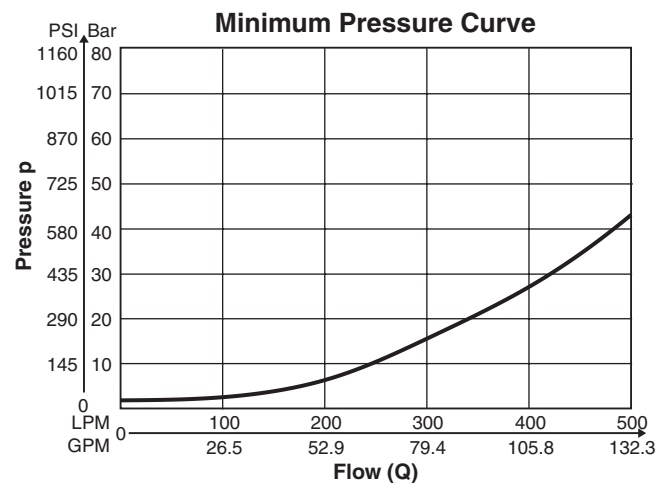
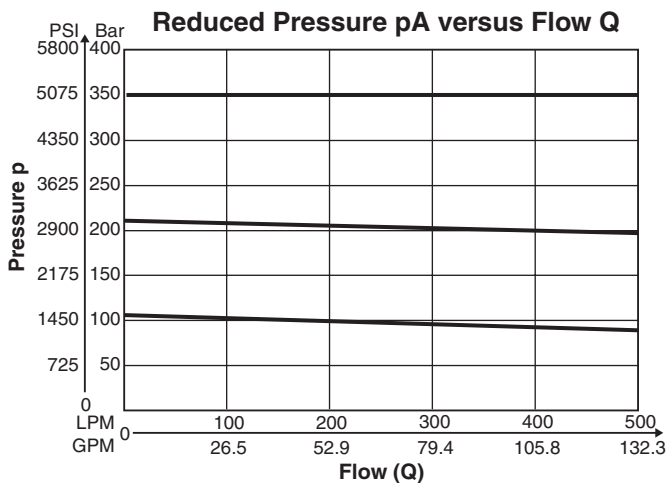

¹⁾ Measured at 350 Bar (5075 PSI) primary pressure pB.

Inch equivalents for millimeter dimensions are shown in (**)

T-Body

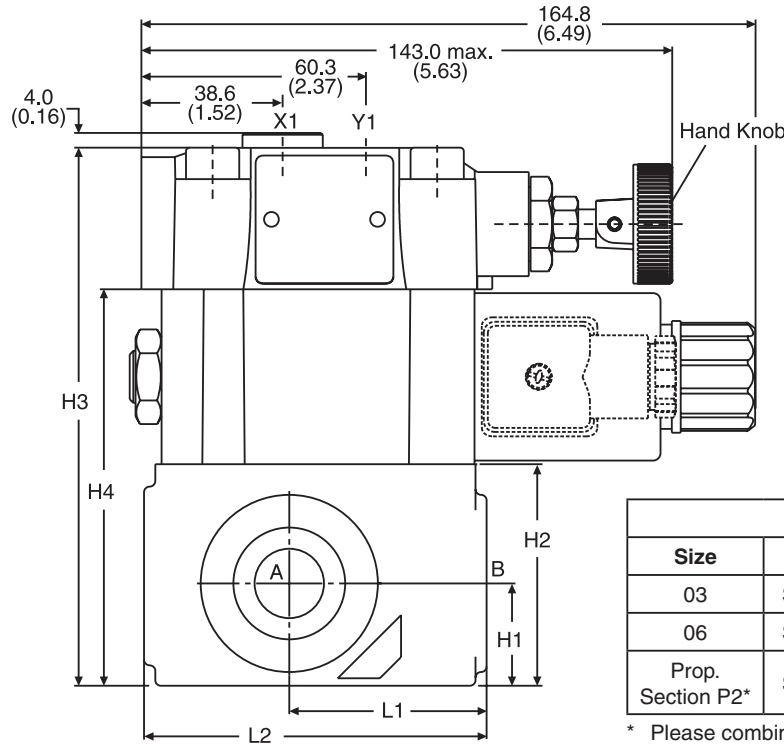
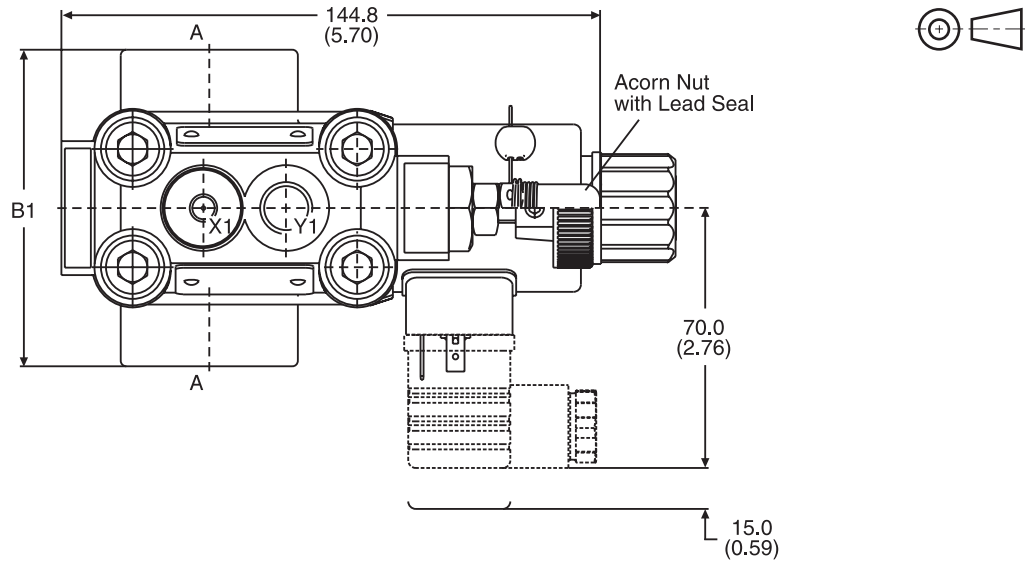

Seal Kits		
Size	Nitrile	Fluorocarbon
03	S26-58507-0	S26-58507-5
06	S26-58475-0	S26-58475-5
Prop. Section P2*	S26-58473-0	S26-58473-5

* Please combine seal kit of one size with seal kit of Prop. Section P2 for complete seal kit.

Size	Body	B1	H1	H2	H3	H4	L1	L2
03	T-Body	85.0 (3.35)	27.5 (1.08)	59.5 (2.34)	144.5 (5.69)	106.5 (4.19)	53.0 (2.09)	92.0 (3.62)
06	T-Body	136.0 (5.35)	38.0 (1.50)	93.0 (3.66)	178.0 (7.01)	140.0 (5.51)	66.5 (2.62)	117.5 (4.63)

Port	Function	Port Size	
		R4R03*P2 T-Body	R4R06*P2 T-Body
B	Inlet Pressure	G1/2"	G1"
A	Outlet Pressure	G1/2"	G1"
X1*	External Remote Control or Vent Connection	G1/4"	
Y1	External Drain		

* Closed when supplied.

Dimensions

Inch equivalents for millimeter dimensions are shown in (**)

L-Body

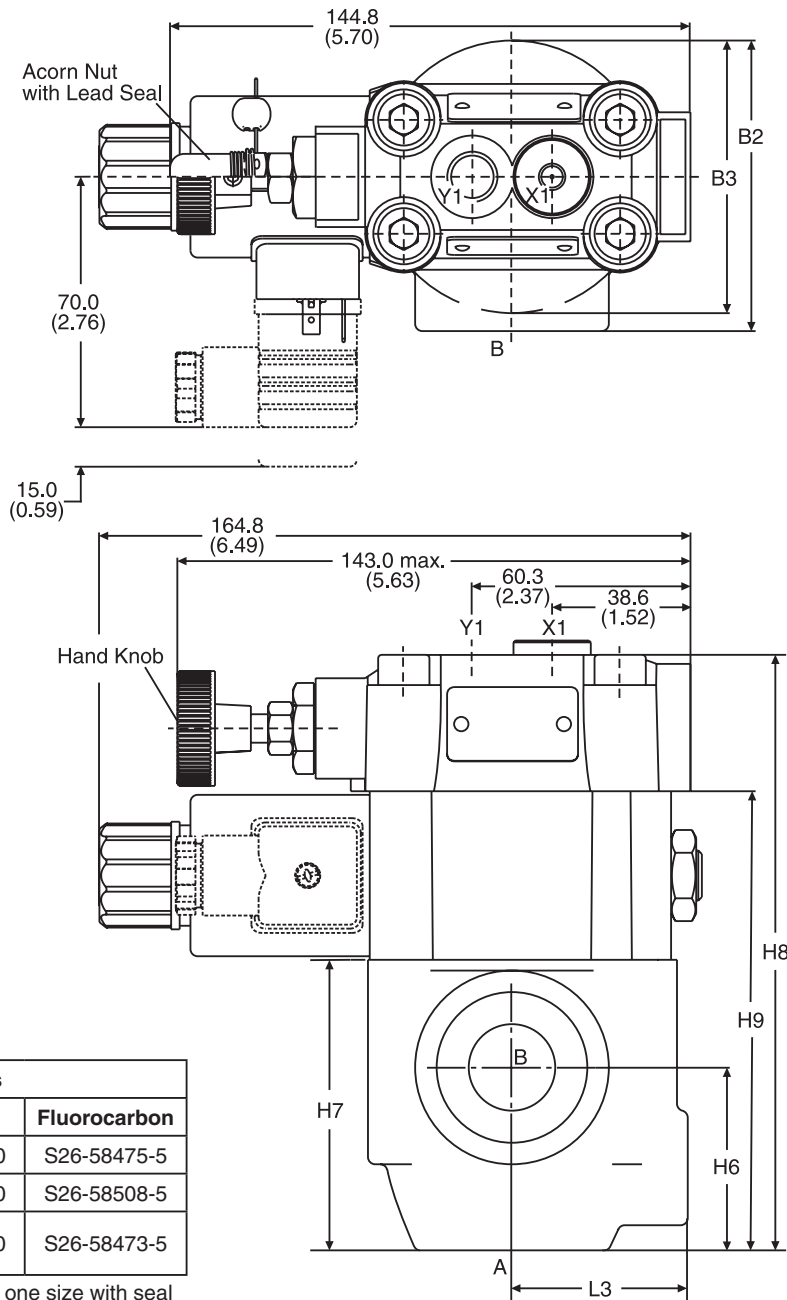

Seal Kits		
Size	Nitrile	Fluorocarbon
06	S26-58475-0	S26-58475-5
10	S26-58508-0	S26-58508-5
Prop. Section P2*	S26-58473-0	S26-58473-5

* Please combine seal kit of one size with seal kit of Prop. Section P2 for complete seal kit.

Size	Body	B2	B3	H6	H7	H8	H9	L3
06	L-Body	81.0 (3.19)	76.0 (2.99)	51.0 (2.01)	81.0 (3.19)	166.0 (6.54)	128.0 (5.04)	49.0 (1.93)
10	L-Body	120.7 (4.75)	85.8 (3.38)	50.8 (2.00)	96.0 (3.78)	181.0 (7.13)	143.0 (5.63)	49.8 (1.96)

Port	Function	Port Size	
		R4R06*P2 L-Body	R4R10*P2 L-Body
B	Inlet Pressure	G3/4"	G1-1/4"
A	Outlet Pressure	G3/4"	G1-1/4"
X1*	External Remote Control or Vent Connection	G1/4"	
Y1	External Drain	G1/4"	

* Closed when supplied.

B01_Cat2550.indd, ddp, 04/19

