

Parker Series R4R*P2 Pilot Operated Pressure Reducing Valve, Subplate Mounting Service Manual

Technical Information

General Description

Series R4R*P2 subplate mounted proportional pressure reducing valves have a proportional solenoid operated pilot stage and a cartridge main stage.

The optimum performance can be achieved in combination with the digital amplifier module PCD00A-400.

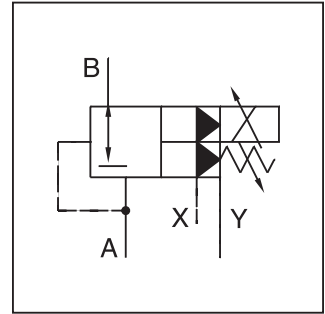

B

Features

- Pilot operated with proportional solenoid
- Continuous adjustment by proportional solenoid
- Subplate mounting according to ISO 5781
- 3 pressure ranges
- Mechanical maximum pressure adjustment

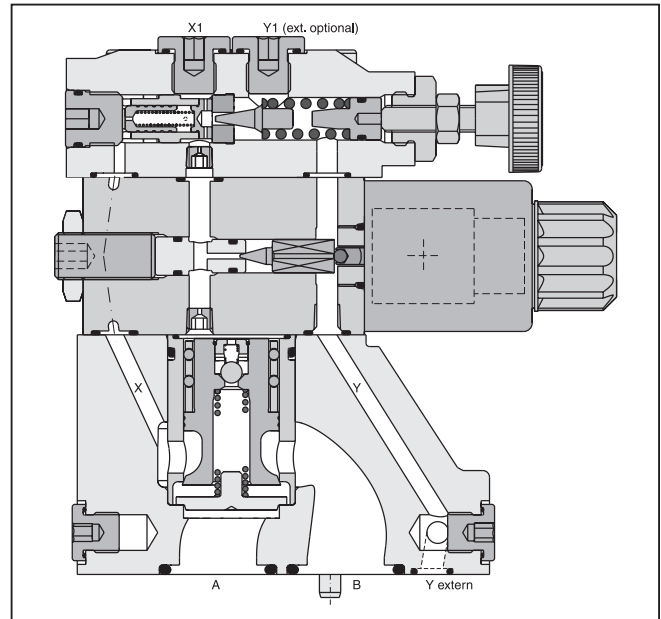

Ordering Information

R	4	R		5	9				P2	G0R	B																							
Pressure Reducing Valve	Interface	Reducing Function	Size	Maximum Pressure 350 Bar (5075 PSI)	Pilot Ports G1/4"	Pressure Range	Adjustment	Drain Line Ext. from Pilot Head (Y1)	Proportional Pressure Control	Solenoid Voltage 12V 2.3A	Design Series	Seal	Options Check with Factory																					
			<table border="1"> <thead> <tr> <th>Code</th> <th>Description</th> </tr> </thead> <tbody> <tr> <td>03</td> <td>NG10</td> </tr> <tr> <td>06</td> <td>NG25</td> </tr> <tr> <td>10</td> <td>NG32</td> </tr> </tbody> </table>		Code	Description	03	NG10	06	NG25	10	NG32				<table border="1"> <thead> <tr> <th>Code</th> <th>Pilot</th> <th>Drain</th> </tr> </thead> <tbody> <tr> <td>1</td> <td>Internal</td> <td>External from Y</td> </tr> <tr> <td>2</td> <td>Internal</td> <td>External from Y1</td> </tr> </tbody> </table>		Code	Pilot	Drain	1	Internal	External from Y	2	Internal	External from Y1	<table border="1"> <thead> <tr> <th>Code</th> <th>Description</th> </tr> </thead> <tbody> <tr> <td>1</td> <td>Nitrile</td> </tr> <tr> <td>5</td> <td>Fluorocarbon</td> </tr> </tbody> </table>		Code	Description	1	Nitrile	5	Fluorocarbon
Code	Description																																	
03	NG10																																	
06	NG25																																	
10	NG32																																	
Code	Pilot	Drain																																
1	Internal	External from Y																																
2	Internal	External from Y1																																
Code	Description																																	
1	Nitrile																																	
5	Fluorocarbon																																	
<table border="1"> <thead> <tr> <th>Code</th> <th>Description</th> </tr> </thead> <tbody> <tr> <td>4</td> <td>Subplate Mounting ISO 5781</td> </tr> </tbody> </table>			Code	Description	4	Subplate Mounting ISO 5781	<table border="1"> <thead> <tr> <th>Code</th> <th>Description</th> </tr> </thead> <tbody> <tr> <td>1</td> <td>Hand Knob 32mm dia. Standard</td> </tr> <tr> <td>3</td> <td>Acorn Nut with Lead Seal</td> </tr> </tbody> </table>			Code	Description	1	Hand Knob 32mm dia. Standard	3	Acorn Nut with Lead Seal	<p>Bolt Kit:</p> <table border="1"> <tbody> <tr> <td>R4R03*P2</td> <td>BK505</td> </tr> <tr> <td>R4R06*6*P2</td> <td>BK485</td> </tr> <tr> <td>R4R10*P2</td> <td>BK506</td> </tr> </tbody> </table>		R4R03*P2	BK505	R4R06*6*P2	BK485	R4R10*P2	BK506											
Code	Description																																	
4	Subplate Mounting ISO 5781																																	
Code	Description																																	
1	Hand Knob 32mm dia. Standard																																	
3	Acorn Nut with Lead Seal																																	
R4R03*P2	BK505																																	
R4R06*6*P2	BK485																																	
R4R10*P2	BK506																																	
			<table border="1"> <thead> <tr> <th>Code</th> <th>Description</th> </tr> </thead> <tbody> <tr> <td>1</td> <td>up to 105 Bar (1523 PSI)</td> </tr> <tr> <td>3</td> <td>up to 210 Bar (3045 PSI)</td> </tr> <tr> <td>5</td> <td>up to 350 Bar (5075 PSI)</td> </tr> </tbody> </table>			Code	Description	1	up to 105 Bar (1523 PSI)	3	up to 210 Bar (3045 PSI)	5	up to 350 Bar (5075 PSI)	<p>Weight:</p> <table border="1"> <tbody> <tr> <td>R4R03*P2</td> <td>2.7 kg (6.0 lbs.)</td> </tr> <tr> <td>R4R06*6*P2</td> <td>4.5 kg (9.9 lbs.)</td> </tr> <tr> <td>R4R10*P2</td> <td>6.0 kg (13.2 lbs.)</td> </tr> </tbody> </table>		R4R03*P2	2.7 kg (6.0 lbs.)	R4R06*6*P2	4.5 kg (9.9 lbs.)	R4R10*P2	6.0 kg (13.2 lbs.)													
Code	Description																																	
1	up to 105 Bar (1523 PSI)																																	
3	up to 210 Bar (3045 PSI)																																	
5	up to 350 Bar (5075 PSI)																																	
R4R03*P2	2.7 kg (6.0 lbs.)																																	
R4R06*6*P2	4.5 kg (9.9 lbs.)																																	
R4R10*P2	6.0 kg (13.2 lbs.)																																	

WARNING: This product can expose you to chemicals including Lead, Nickel (Metallic), or 1,3-Butadiene which are known to the State of California to cause cancer, and Lead or 1,3-Butadiene which is known to the State of California to cause birth defects and other reproductive harm. For more information go to www.P65Warnings.ca.gov.

B01_Cat2550.indd, ddp, 04/19



Specifications

General				
Size		NG10	NG25	NG32
Interface	Subplate mounting acc. ISO 5781			
Mounting Position	Unrestricted, horizontal mounting preferred			
Ambient Temperature	[°C]	-20 ... +80; (-4°F ... +176°F)		
MTTF _D Value	[years]	75		
Hydraulic				
Maximum Operating Pressure	Ports A, B and X 350 Bar (5075 PSI), Port Y depressurized			
Pressure Ranges	105 Bar (1523 PSI), 210 Bar (3045 PSI), 350 Bar (5075 PSI)			
Nominal Flow		150 LPM (39.7 GPM)	350 LPM (92.6 GPM)	500 LPM (132.3 PSI)
Fluid	Hydraulic oil according to DIN 51524...51535, other on request			
Viscosity		30 ... 50 (139 ... 232 SSU)		
Recommended Permitted	[cSt] / [mm²/s]	20 ... 380 (93 ... 1761 SSU)		
Fluid Temperature	[°C]	-20 ... +70 (-4°F ... +158°F)		
Filtration	ISO 4406 (1999) 18/16/13 (acc. NAS 1638: 7)			
Electrical				
Duty Ratio	[%]	100 ED; CAUTION: Coil temperature up to 150°C (302°F) possible		
Protection Class	IP65 in accordance with EN 60529 (plugged and mounted)			
Nominal Voltage	[V]	12		
Maximum Current	[A]	2.3		
Coil Resistance	[Ohm]	4 at 20°C (68°F)		
Solenoid Connection	Connector as per EN 175301-803, Solenoid identification as per ISO9461			
Power Amplifier, Recommended	PCD00A-400			

B

Performance Curves

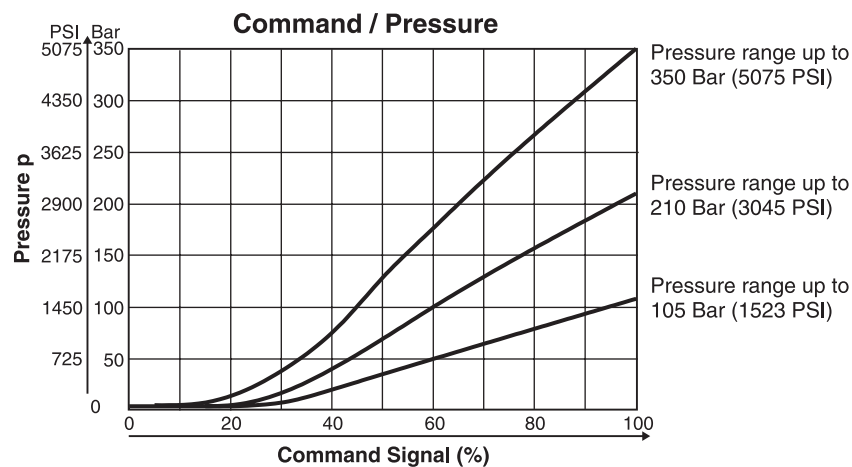

Performance Curves

R4R03*P2 ¹⁾

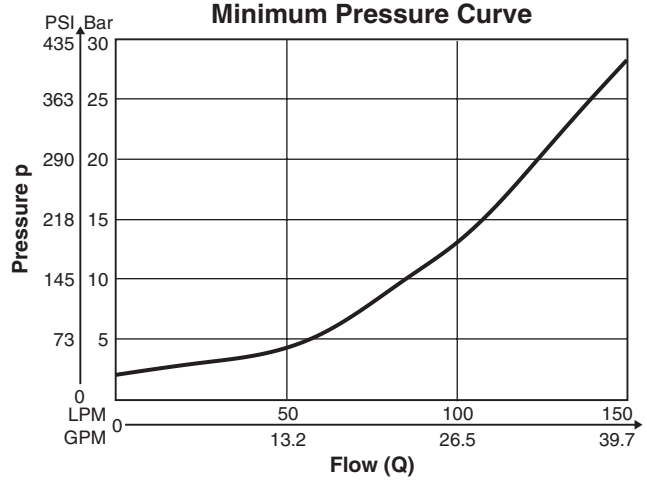
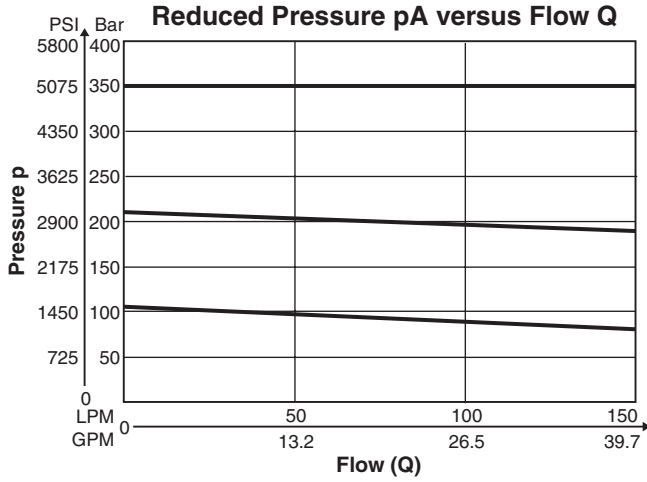

R4R06*P2 ¹⁾

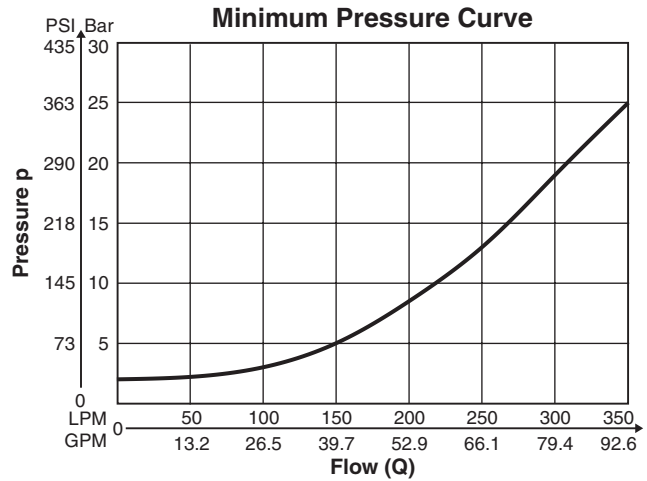
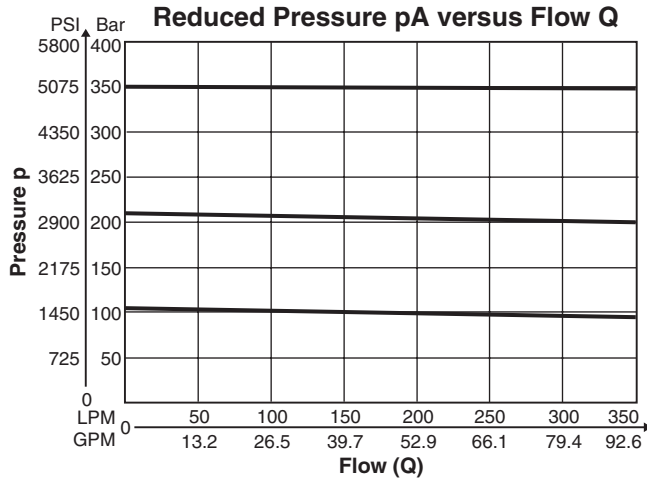

R4R10*P2 ¹⁾

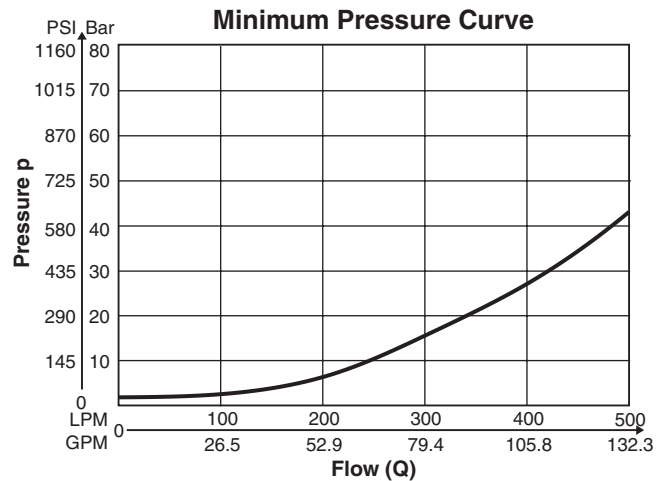
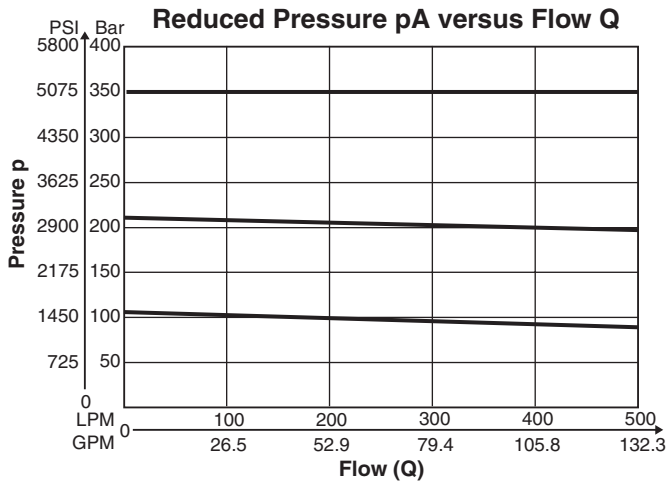

¹⁾ Measured at 350 Bar (5075 PSI) primary pressure pB.

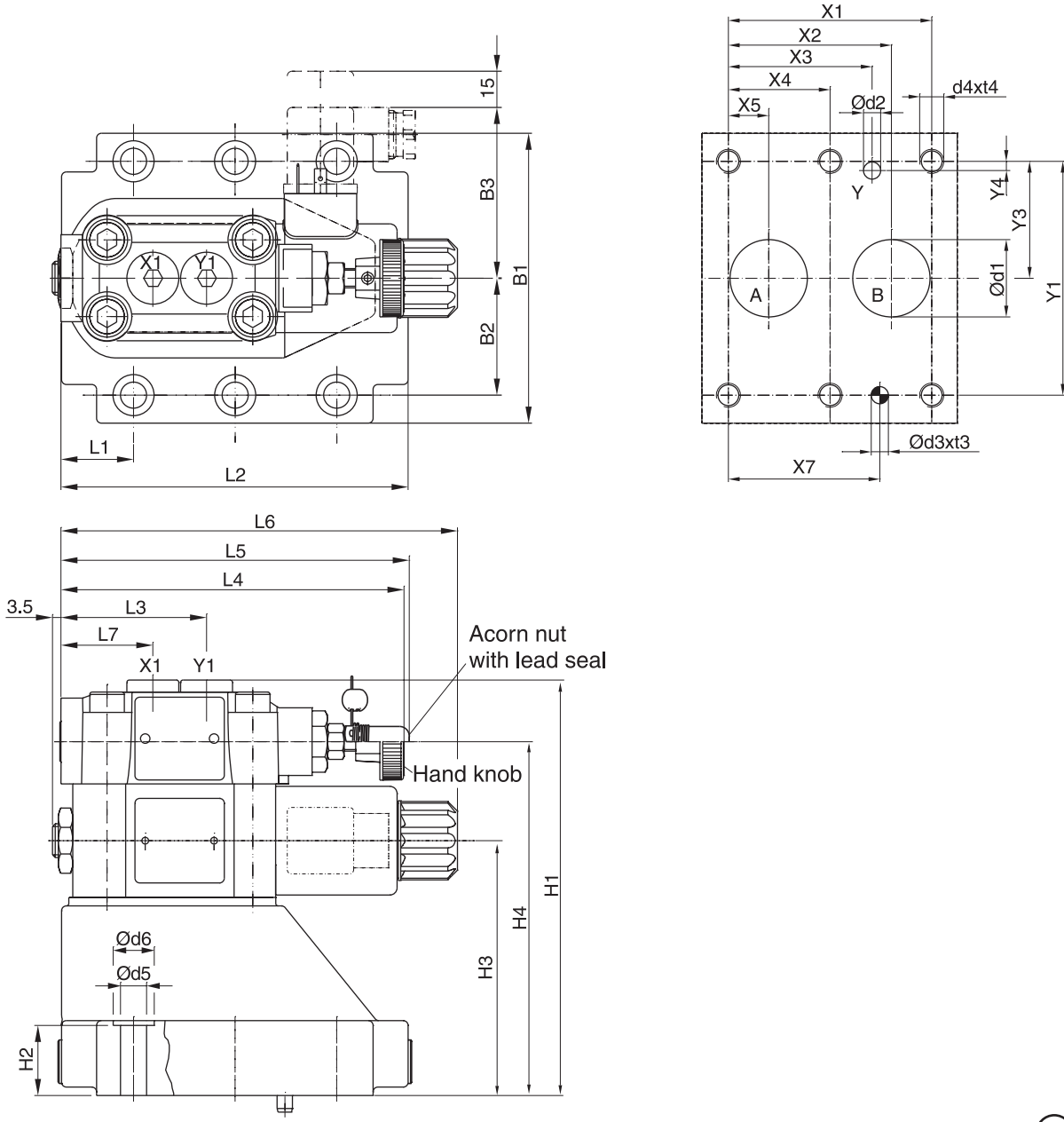

B



Dimensions



Inch equivalents for millimeter dimensions are shown in (**)

NG	ISO-Code	x1	x2	x3	x4	x5	x6	x7	y1	y2	y3	y4	y5	y6
10	5781-06-07-0-00	42.9 (1.69)	35.8 (1.41)	21.5 (0.85)	-	7.2 (0.28)	-	31.8 (1.25)	66.7 (2.63)	-	33.4 (1.31)	7.9 (0.31)	-	-
25	5781-08-10-0-00	60.3 (2.37)	49.2 (1.94)	39.7 (1.56)	-	11.1 (0.44)	-	44.5 (1.75)	79.4 (3.13)	-	39.7 (1.56)	6.4 (0.25)	-	-
32	5781-10-13-0-00	84.2 (3.31)	67.5 (2.66)	59.5 (2.34)	42.1 (1.66)	16.7 (0.66)	-	62.7 (2.47)	96.8 (3.81)	-	48.4 (1.91)	3.8 (0.15)	-	-

Tolerance at X and Y pin holes and screw holes ± 0.1 , at port holes ± 0.2 .

NG	ISO-Code	B1	B2	B3	H1	H2	H3	H4	L1	L2	L3	L4	L5	L6	L7
10	5781-06-07-0-00	87.3 (3.44)	33.4 (1.31)	71.0 (2.80)	134.0 (5.28)	21.0 (0.83)	68.5 (2.70)	109.5 (4.31)	25.0 (0.98)	90.8 (3.57)	60.8 (2.38)	143.0 (5.63)	144.8 (5.70)	164.0 (6.49)	38.6 (1.52)
25	5781-08-10-0-00	105.0 (4.13)	39.7 (1.56)	71.0 (2.80)	158.5 (6.24)	29.0 (1.14)	95.0 (3.74)	136.0 (5.35)	30.9 (1.22)	123.0 (4.84)	60.8 (2.38)	143.0 (5.63)	144.8 (5.70)	164.0 (6.49)	38.6 (1.52)
32	5781-10-13-0-00	120.0 (4.72)	48.4 (1.91)	71.0 (2.80)	171.0 (6.73)	30.0 (1.18)	105.5 (4.15)	146.5 (5.77)	29.8 (1.17)	143.5 (5.65)	60.8 (2.38)	143.0 (5.63)	144.8 (5.70)	164.0 (6.49)	38.6 (1.52)

NG	ISO-Code	d1max	d2max	d3	t3	d4	t4	d5	d6	Subplate
10	5781-06-07-0-00	15.0 (0.59)	7.0 (0.28)	7.1 (0.28)	8.0 (0.31)	M10	16.0 (0.63)	10.8 (0.43)	17.0 (0.67)	SPP3M6B910
25	5781-08-10-0-00	23.4 (0.92)	7.1 (0.28)	7.1 (0.28)	8.0 (0.31)	M10	18.0 (0.71)	10.8 (0.43)	17.0 (0.67)	SPP6M8B910
32	5781-10-13-0-00	32.0 (1.26)	7.1 (0.28)	7.1 (0.28)	8.0 (0.31)	M10	20.0 (0.79)	10.8 (0.43)	17.0 (0.67)	SPP10M12B910

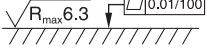
NG	ISO-Code	Bolt Kit			Seal Kit		Surface Finish
					Nitrile	Fluorocarbon	
10	5781-06-07-0-00	BK505	4x M10 x 35 DIN912 12.9	63 Nm (46.5 lb.-ft.) $\pm 15\%$	S26-58507-0*	S26-58507-5*	
25	5781-08-10-0-00	BK485	4x M10 x 45 DIN912 12.9	63 Nm (46.5 lb.-ft.) $\pm 15\%$	S26-58475-0*	S26-58475-5*	
32	5781-10-13-0-00	BK506	6x M10 x 45 DIN912 12.9	63 Nm (46.5 lb.-ft.) $\pm 15\%$	S26-58508-0*	S26-58508-5*	
Prop. Section P2					S26-58473-0	S26-58473-5	

* Please combine seal kit of one size with seal kit of Prop. Section P2 for complete seal kit