

Parker Series R4S Pilot Operated Sequence Valve Service Manual

Subplate mounted sequence valves series R4S enable a hydraulic system to operate in a pressure sequence. When the system pressure reaches the setting pressure the valve opens and permits flow to the secondary sub-system.

Features

- Pilot operated sequence valve
- Subplate mounting acc. to ISO 5781
- 3 pressure stages
- 3 adjustment modes:
 - hand knob
 - acorn nut with lead seal
 - cylinder lock

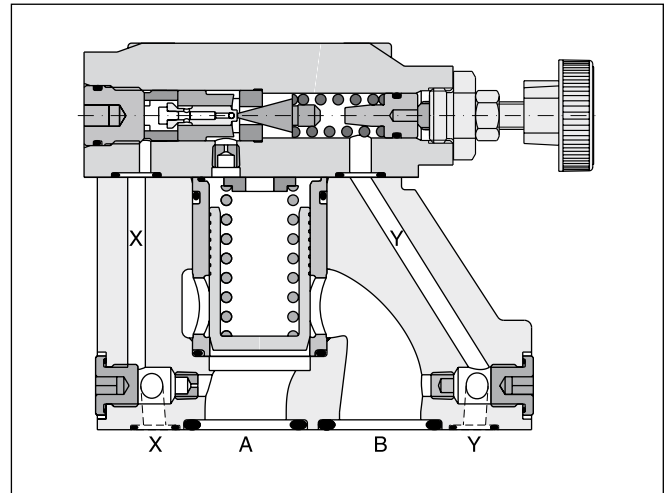
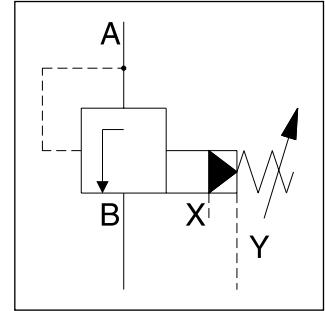

4

Ordering code

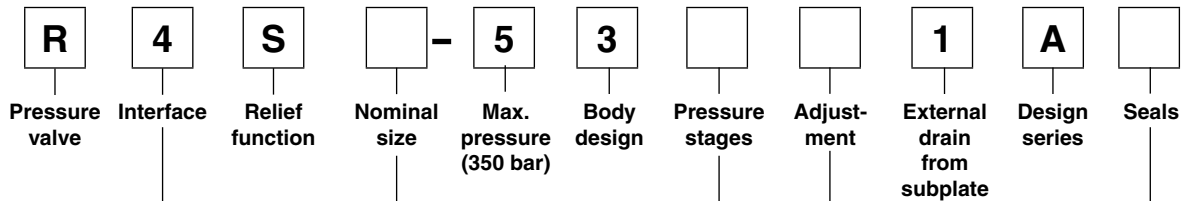

Code	Interface	
4	Subplate mounting ISO 5781	Pin

Code	Seals
1	NBR
5	FPM

Code	Nominal size
03	NG10
06	NG25
10	NG32

Code	Adjustment
1	Hand knob 32 mm diameter (standard)
3	Acorn nut with lead seal
4	Cylinder lock

Code	Pressure stages
1	up to 105 bar
3	up to 210 bar
5	up to 350 bar

Technical Data / Characteristics Curve

Technical data

General				
Nominal size		NG10	NG25	NG32
Interface	Subplate mounting acc. ISO 5781			
Mounting position	Unrestricted, horizontal mounting preferred			
Ambient temperature	[°C]	-20...+60		
MTTF _D value	[years]	75		
Weight	[kg]	2.7	4.5	6.0
Hydraulic				
Max. operating pressure	[bar]	Ports A, B and X 350, port Y depressurized		
Pressure stages	[bar]	105, 210, 350		
Nominal flow	[l/min]	150	350	650
Fluid	Hydraulic oil according to DIN 51524			
Viscosity, permitted recommended	[cSt] / [mm ² /s]	20 ... 400		
	[cSt] / [mm ² /s]	30 ... 80		
Fluid temperature	[°C]	-20...+70 (NBR: -25...+70)		
Filtration	ISO 4406 (1999); 18/16/13			

4

Typical pressure characteristics at closing point

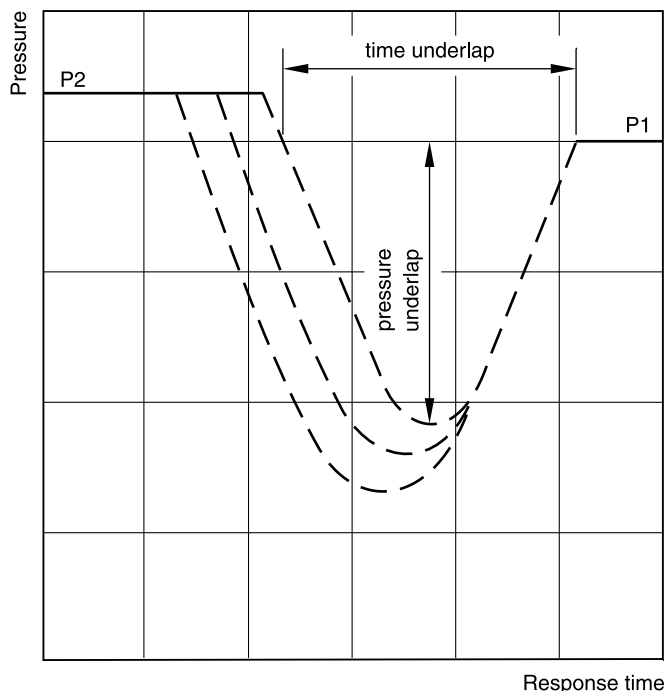

P1 = setting pressure
P2 = operating pressure

Time and pressure underlap depend on the characteristics of the specific system.

Dimensions

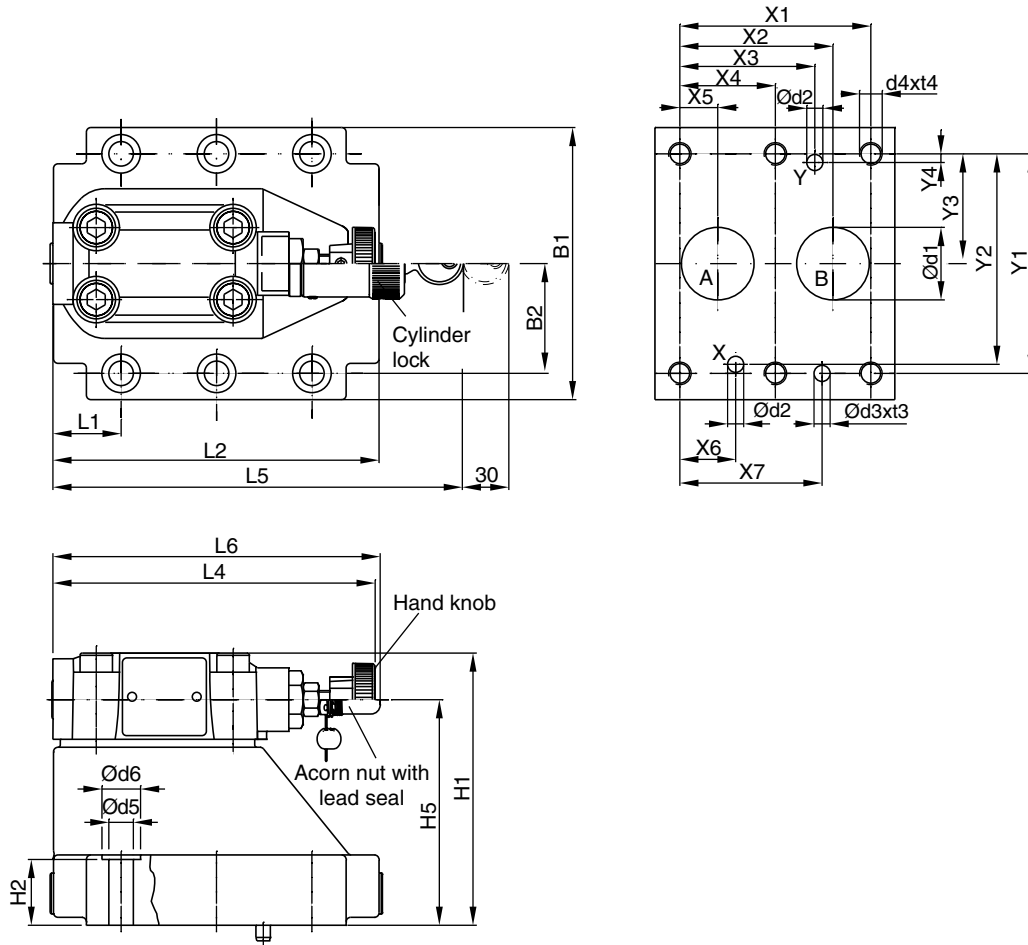

NG	ISO-code	x1	x2	x3	x4	x5	x6	x7	y1	y2	y3	y4	y5	y6
10	5781-06-07-0-00	42.9	35.8	21.5	-	7.2	21.5	31.8	66.7	58.8	33.4	7.9	-	-
25	5781-08-10-0-00	60.3	49.2	39.7	-	11.1	20.6	44.5	79.4	73	39.7	6.4	-	-
32	5781-10-13-0-00	84.2	67.5	59.5	42.1	16.7	24.6	62.7	96.8	92.8	48.4	3.8	-	-

Tolerance at X and Y pin holes and screw holes ± 0.1 , at port holes ± 0.2 .

NG	ISO-code	B1	B2	H1	H2	H3	H4	H5	H6	L1	L2	L3	L4	L5	L6
10	5781-06-07-0-00	87.3	33.35	83	21	-	-	62.5	-	25	90.8	-	143	181	144.8
25	5781-08-10-0-00	105	39.7	107.5	29	-	-	87	-	30.9	123	-	143	181	144.8
32	5781-10-13-0-00	120	48.4	120	30	-	-	99.5	-	29.8	143.5	-	143	181	144.8

NG	ISO-code	d1max	d2max	d3	t3	d4	t4	d5	d6	Subplate ¹⁾
10	5781-06-07-0-00	15	7	7.1	8	M10	16	10.8	17	SPP 3M6B 910
25	5781-08-10-0-00	23.4	7.1	7.1	8	M10	18	10.8	17	SPP 6M8B 910
32	5781-10-13-0-00	32	7.1	7.1	8	M10	20	10.8	17	SPP 10M12B 910

NG	Bolt kit			Kit		Surface finish
				NBR	FPM	
10	BK505	4x M10x35 ISO 4762-12.9	63 Nm ± 15 %	S26-58507-0	S26-58507-5	
25	BK485	4x M10x45 ISO 4762-12.9	63 Nm ± 15 %	S26-58475-0	S26-58475-5	
32	BK506	6x M10x45 ISO 4762-12.9	63 Nm ± 15 %	S26-58508-0	S26-58508-5	

¹⁾ Details see chapter 12, series SPP.