

# Parker Series R4U Unloading Valve, Subplate Mounting Service Manual

Subplate mounted unloading valves series R4U are used to unload a circuit at low pressure. The mechanically adjustable pressure signal to unload the main stage has to be applied to port X. The pressure differential between opening and closing is nominal 15 or 28 % of the setting pressure:

28 % for pressure stages 105 and 210 bar

15 % for pressure stage 350 bar

Typical applications are unloading of pumps in an accumulator circuit or unloading of the low pressure stage of a double pump.

The R4U is available with an electrical vent valve for unpressurized circulation.

## Features

- Pilot operated unloading valve
- Interface
  - subplate mounting to ISO 5781
- 3 pressure stages
- 2 vent valve functions
- 3 adjustment modes:
  - hand knob
  - acorn nut with lead seal
  - cylinder lock

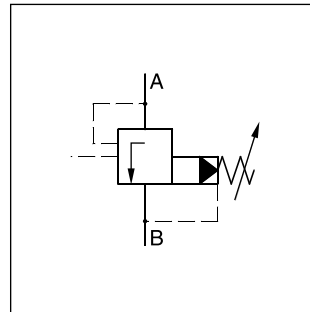

R4U

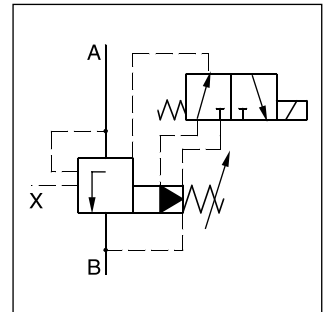

R4U with vent function

4

## R4U06

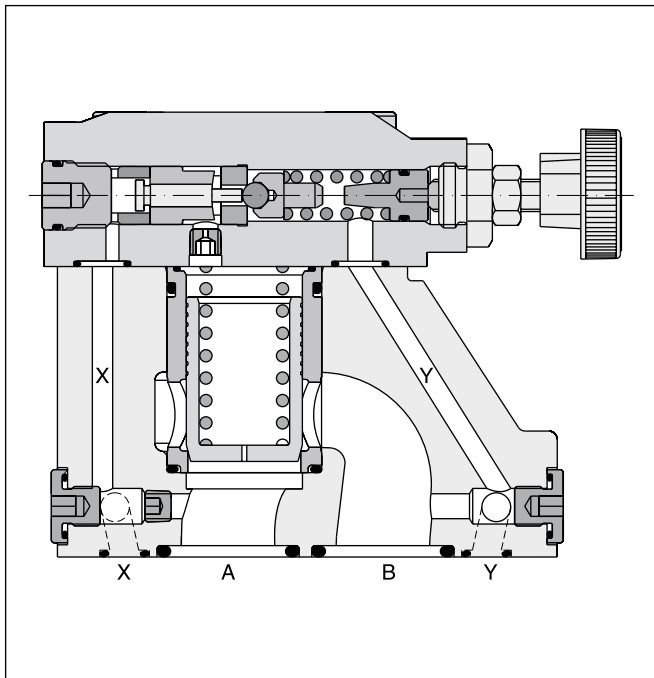

## R4U06 with vent function

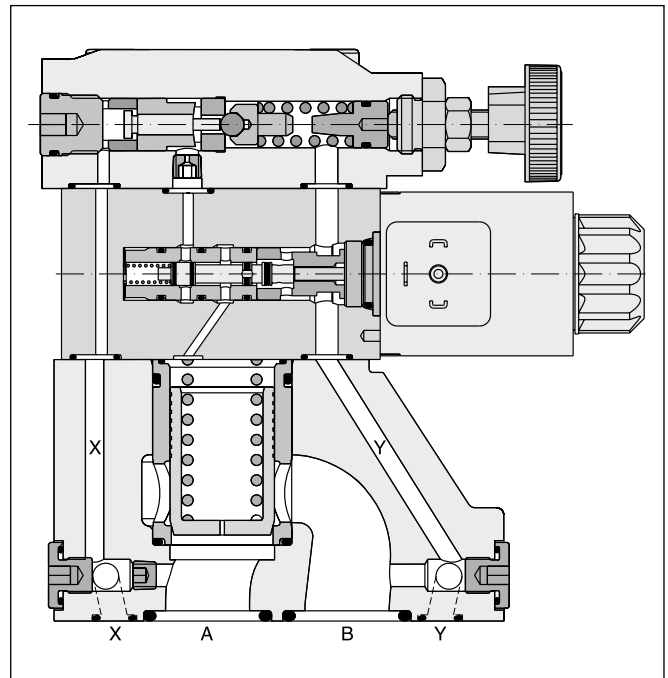

**R4U**

**R** Pressure valve  
**4** Interface  
**U** Unloading function  
 - **5** Max. pressure (350 bar)  
**3** Body design  
 - **A** Design series  
 - **Seals** Seals  
 - **Modifications** Modifications

Code	Interface	
4	Subplate mounting ISO 5781	

Code	Nominal size
03	NG10
06	NG25
10	NG32

Code	Pressure stages	Pressure differential
1	up to 105 bar	28 %
3	up to 210 bar	28 %
5	up to 350 bar	15 %

Code	Seals
1	NBR
5	FPM

Pilot oil	
Code	Drain line
0	Internal
1	Ext. from subplate

Code	Adjustment
1	Hand knob 32 mm diameter (standard)
3	Acorn nut with lead seal
4	Cylinder lock

**R4U with vent function**

**R** Pressure valve  
**4** Interface  
**U** Relief function  
 - **5** Max. pressure (350 bar)  
**3** Body design  
 - **Adjustment** Adjustment  
 - **Pilot oil** Pilot oil  
**Vent valve function** Vent valve function  
**Solenoid voltage** Solenoid voltage  
**A** Design series  
**Seals** Seals  
**Modifications** Modifications

Code	Interface	
4	Subplate mounting ISO 5781	

Code	Nominal size
03	NG10
06	NG25
10	NG32

Code	Pressure stages	Pressure differential
1	up to 105 bar	28 %
3	up to 210 bar	28 %
5	up to 350 bar	15 %

Code	Adjustment
1	Hand knob (standard)
3	Acorn nut with lead seal
4	Cylinder lock

Code	Seals
1	NBR
5	FPM

Voltage	
G0R	12 V =
G0Q	24 V =
GAR <sup>1)</sup>	98 V =
GAG <sup>1)</sup>	205 V =
W30	110 V / 50 Hz 120 V / 60 Hz
W31	230 V / 50 Hz 240 V / 60 Hz

Code	Vent valve
09	Solenoid not activ. unpress. circulation
11	Solenoid activated unpress. circulation

Pilot oil	
Code	Drain line
0	Internal
1	Ext. from subplate

<sup>1)</sup> To be used in combination with rectifier plugs at 120 VAC resp. 230 VAC power supply.

# Technical Data

## R4U

General		NG10	NG25	NG32
Nominal size				
Interface		Subplate mounting acc. ISO 5781		
Mounting position		Unrestricted, horizontal mounting preferred		
Ambient temperature	[°C]	-20...+60		
MTTF <sub>D</sub> value	[years]	75		
Weight	[kg]	2.7	4.5	6.0
Hydraulic				
Max. operating pressure	[bar]	Ports A and X 350, Ports B and Y depressurized		
Pressure stages	[bar]	105, 210, 350		
Pressure differential		28 % (for pressure stages 105 bar and 210 bar); 15 % (for pressure stages 350 bar)		
Nominal flow	[l/min]	150	350	650
Fluid		Hydraulic oil according to DIN 51524		
Viscosity, permitted	[cSt] / [mm <sup>2</sup> /s]	20 ... 400		
recommended	[cSt] / [mm <sup>2</sup> /s]	30 ... 80		
Fluid temperature	[°C]	-20...+70 (NBR: -25...+70)		
Filtration		ISO 4406 (1999); 18/16/13		

4

## R4U with vent function

General		NG10	NG25	NG32			
Nominal size							
Interface		Subplate mounting acc. ISO 5781					
Mounting position		Unrestricted, horizontal mounting preferred					
Ambient temperature	[°C]	-20...+60					
MTTF <sub>D</sub> value	[years]	75					
Weight	[kg]	4.4	6.2	7.7			
Hydraulic							
Max. operating pressure	[bar]	Ports A and X 350, Ports B and Y depressurized					
Pressure stages	[bar]	105, 210, 350					
Pressure differential		28 % (for pressure stages 105 bar and 210 bar); 15 % (for pressure stages 350 bar)					
Nominal flow	[l/min]	150	350	650			
Fluid		Hydraulic oil according to DIN 51524					
Viscosity, permitted	[cSt] / [mm <sup>2</sup> /s]	20 ... 400					
recommended	[cSt] / [mm <sup>2</sup> /s]	30 ... 80					
Fluid temperature	[°C]	-20...+70 (NBR: -25...+70)					
Filtration		ISO 4406 (1999); 18/16/13					
Electrical (solenoid)							
Duty ratio	[%]	100 ED; CAUTION: coil temperature up to 150 °C possible					
Protection class		IP65 in according with EN 60529 (with correctly mounted plug-in connector)					
	Code	G0R	G0Q	GAR	GAG	W30	W31
Supply voltage	[V]	12 V =	24 V =	98 V =	205 V =	110 V / 50 Hz 120 V / 60 Hz	230 V / 50 Hz 240 V / 60 Hz
Tolerance supply voltage	[%]	±10	±10	±10	±10	±5	±5
Current consumption	hold [A]	2.72	1.29	0.33	0.13	0.6 / 0.55	0.3 / 0.27
	in rush [A]	2.72	1.29	0.33	0.13	2.5 / 2.4	1.25 / 1.2
Power consumption	hold [W]	32.7	31	31.9	28.2	70 / 70 VA	70 / 70 VA
	in rush [W]	32.7	31	31.9	28.2	280 / 290 VA	280 / 290 VA
Solenoid connection		Connector as per EN175301-803, solenoid identification as per ISO 9461					
Wiring min.	[mm <sup>2</sup> ]	3 x 1.5 recommended					
Wiring length max.	[m]	50 recommended					

**p/Q performance curve <sup>1)</sup>**

**Minimum pressure curve**

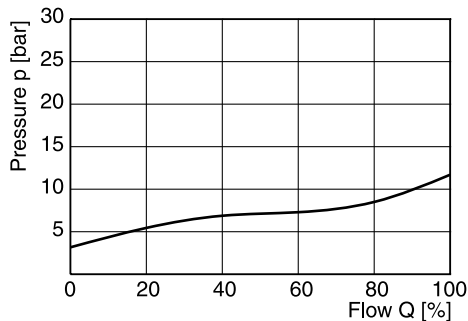
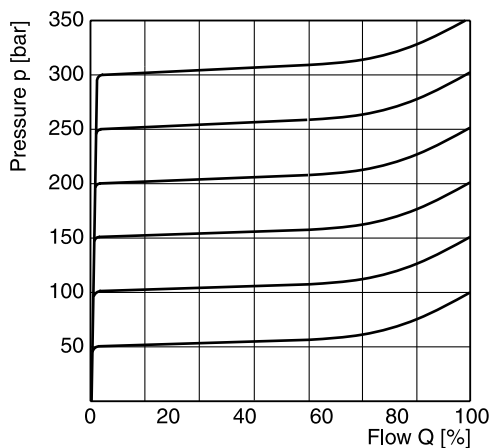

All characteristic curves measured with HLP46 at 50 °C.

<sup>1)</sup> The performance curves are measured with external drain.  
For internal drain the tank pressure has to be added to curve.

# Dimensions

## R4U

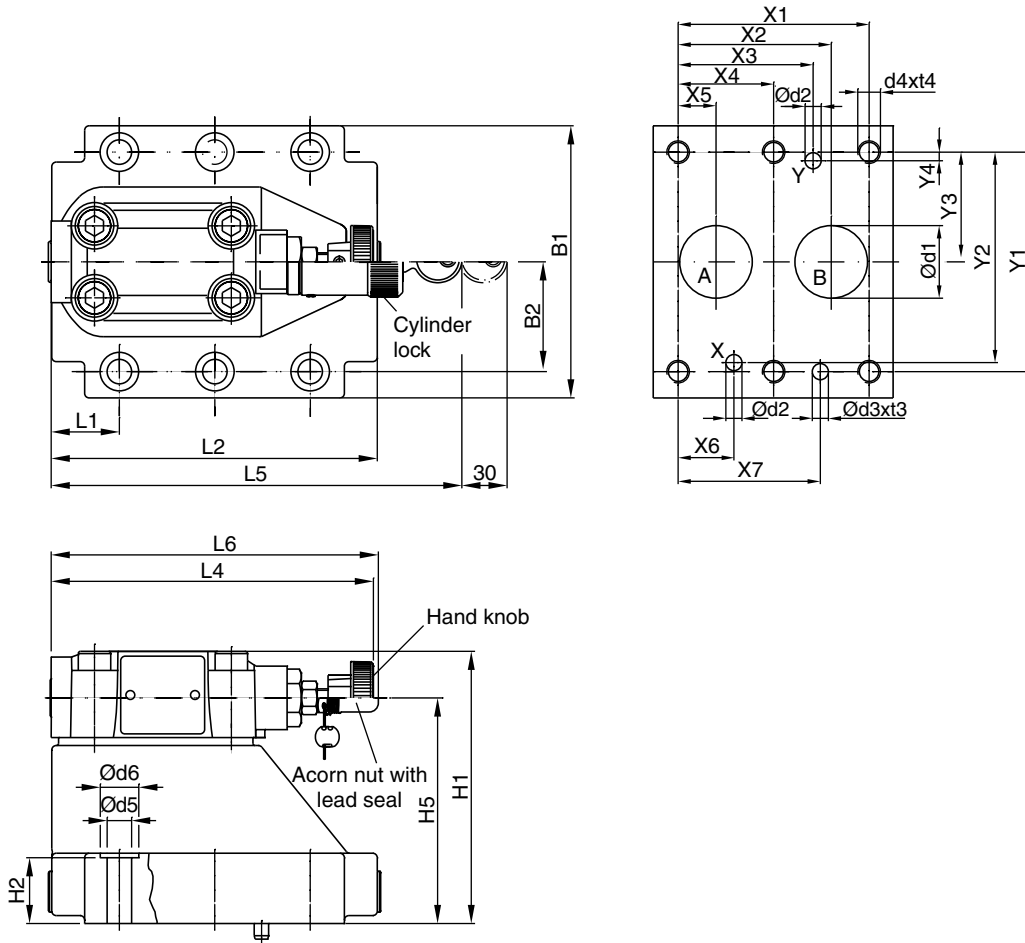

4

NG	ISO-code	x1	x2	x3	x4	x5	x6	x7	y1	y2	y3	y4	y5	y6
10	5781-06-07-0-00	42.9	35.8	21.5	-	7.2	21.5	31.8	66.7	58.8	33.4	7.9	-	-
25	5781-08-10-0-00	60.3	49.2	39.7	-	11.1	20.6	44.5	79.4	73	39.7	6.4	-	-
32	5781-10-13-0-00	84.2	67.5	59.5	42.1	16.7	24.6	62.7	96.8	92.8	48.4	3.8	-	-

Tolerance at X and Y pin holes and screw holes  $\pm 0.1$ , at port holes  $\pm 0.2$ .

NG	ISO-code	B1	B2	H1	H2	H3	H4	H5	H6	L1	L2	L3	L4	L5	L6
10	5781-06-07-0-00	87.3	33.35	83	21	-	-	62.5	-	25	90.8	-	143	181	144.8
25	5781-08-10-0-00	105	39.7	107.5	29	-	-	87	-	30.9	123	-	143	181	144.8
32	5781-10-13-0-00	120	48.4	120	30	-	-	99.5	-	29.8	143.5	-	143	181	144.8

NG	ISO-code	d1max	d2max	d3	t3	d4	t4	d5	d6	Subplate <sup>1)</sup>
10	5781-06-07-0-00	15	7	7.1	8	M10	16	10.8	17	SPP 3M6B 910
25	5781-08-10-0-00	23.4	7.1	7.1	8	M10	18	10.8	17	SPP 6M8B 910
32	5781-10-13-0-00	32	7.1	7.1	8	M10	20	10.8	17	SPP 10M12B 910

NG	Bolt kit	Kit		Surface finish		
		NBR	FPM	Surface finish		
10	BK505	4x M10x35 ISO 4762-12.9	63 Nm $\pm 15$ %	S26-58507-0	S26-58507-5	
25	BK485	4x M10x45 ISO 4762-12.9	63 Nm $\pm 15$ %	S26-58475-0	S26-58475-5	
32	BK506	6x M10x45 ISO 4762-12.9	63 Nm $\pm 15$ %	S26-58508-0	S26-58508-5	

<sup>1)</sup> Details see chapter 12, series SPP.

**R4U with vent function**

4

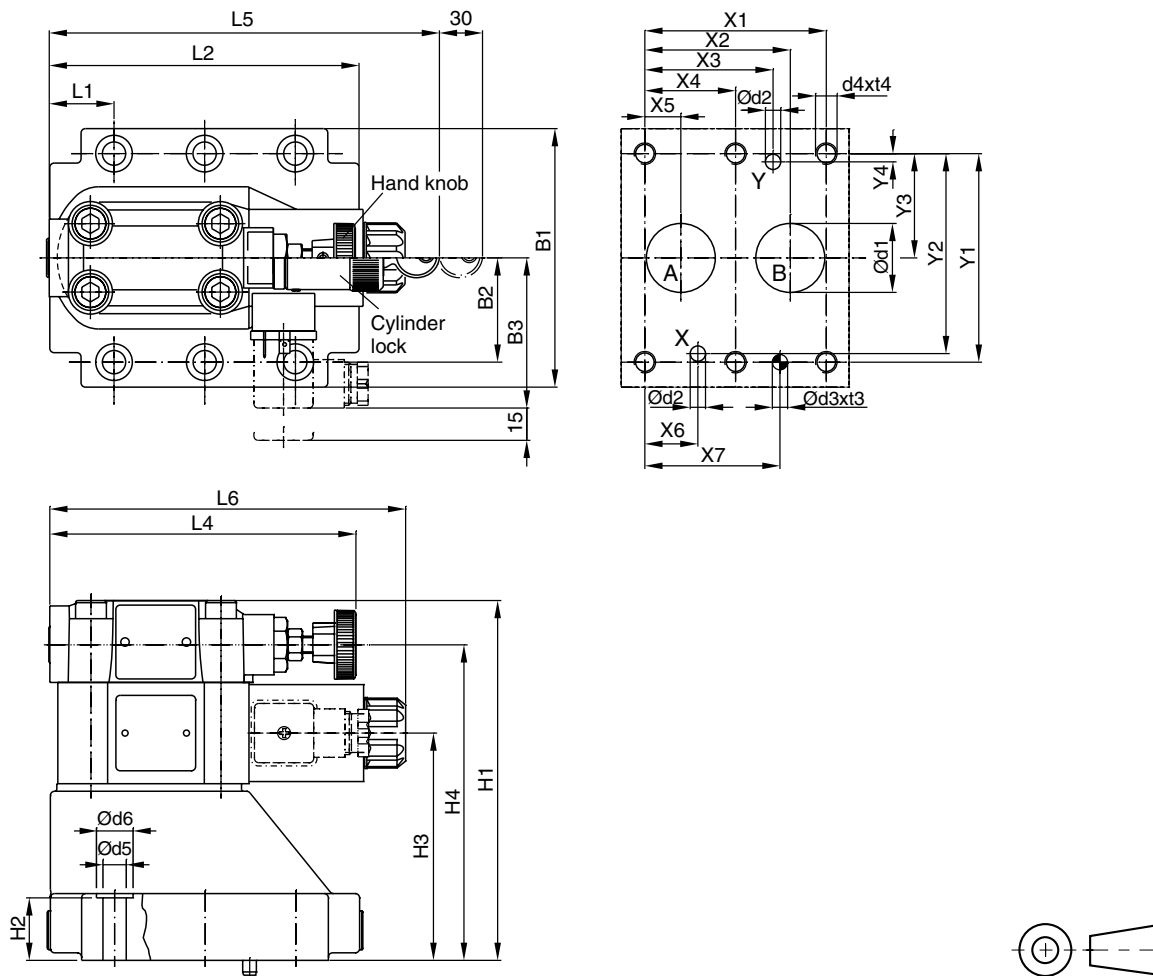

NG	ISO-code	x1	x2	x3	x4	x5	x6	x7	y1	y2	y3	y4	y5	y6
10	5781-06-07-0-00	42.9	35.8	21.5	-	7.2	21.5	31.8	66.7	58.8	33.4	7.9	-	-
25	5781-08-10-0-00	60.3	49.2	39.7	-	11.1	20.6	44.5	79.4	73	39.7	6.4	-	-
32	5781-10-13-0-00	84.2	67.5	59.5	42.1	16.7	24.6	62.7	96.8	92.8	48.4	3.8	-	-

Tolerance at X and Y pin holes and screw holes  $\pm 0.1$ , at port holes  $\pm 0.2$ .

NG	ISO-code	B1	B2	B3	H1	H2	H3	H4	H5	H6	L1	L2	L3	L4	L5	L6
10	5781-06-07-0-00	87.3	33.35	70	130	21	68.5	109.5	-	-	25	90.8	-	143	181	165.6
25	5781-08-10-0-00	105	39.7	70	154.5	29	93	134	-	-	30.9	123	-	143	181	165.6
32	5781-10-13-0-00	120	48.4	70	167	30	105.5	146.5	-	-	29.8	143.5	-	143	181	165.6

NG	ISO-code	d1max	d2max	d3	t3	d4	t4	d5	d6	Subplate <sup>1)</sup>
10	5781-06-07-0-00	15	7	7.1	8	M10	16	10.8	17	SPP 3M6B 910
25	5781-08-10-0-00	23.4	7.1	7.1	8	M10	18	10.8	17	SPP 6M8B 910
32	5781-10-13-0-00	32	7.1	7.1	8	M10	20	10.8	17	SPP 10M12B 910

NG	Bolt kit	Kit		Surface finish
		NBR	FPM	
10	BK505	4x M10x35 ISO 4762-12.9	63 Nm $\pm 15$ %	S26-58507-0 <sup>2)</sup> S26-58507-5 <sup>2)</sup>
25	BK485	4x M10x45 ISO 4762-12.9	63 Nm $\pm 15$ %	S26-58475-0 <sup>2)</sup> S26-58475-5 <sup>2)</sup>
32	BK506	6x M10x45 ISO 4762-12.9	63 Nm $\pm 15$ %	S26-58508-0 <sup>2)</sup> S26-58508-5 <sup>2)</sup>
VV01, AC solenoid				S26-35237-0 S56-40609-0
VV01, DC solenoid				S26-35237-5 S56-40609-5

<sup>1)</sup> Details see chapter 12, series SPP.

<sup>2)</sup> Please combine seal kit of one size with seal kit of VV01 DC / AC solenoid for complete seal kit.