

Parker Series S06M 2-Way Slip-In Cartridge Valve Service Manual

Pilot valve with pressure relief function R06M, sub-plate mounting NG06, see combination examples. MTTF_D value 150 years, flow rate maximum 5 l/min.

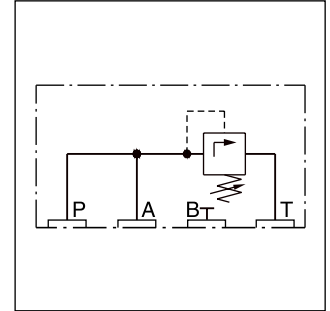

Ordering code

R06M **4**

Pressure range Pressure adjustment Pilot oil Seal Design series (not required for ordering)

Code	Pressure range [bar]
10	105
17	175
21	210
25	250
35	350

Code	Seal
N	NBR
V	FPM

Code	Adjustment
S	Hand knob (standard)
A	Acorn nut with lead seal
L	Cylinder lock

Bold letters = Short-term availability

8

Dimensions

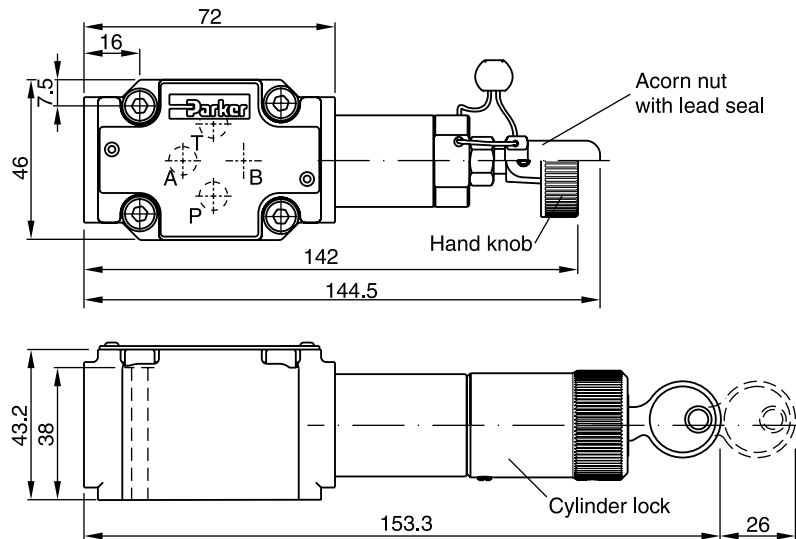

Pilot Valves

Pilot valve with pressure relief function RS06M, sandwich plate mounting NG06, see combination examples. MTTF_D value 150 years, flow rate maximum 5 l/min.

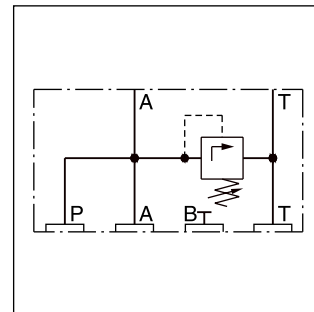

Ordering code

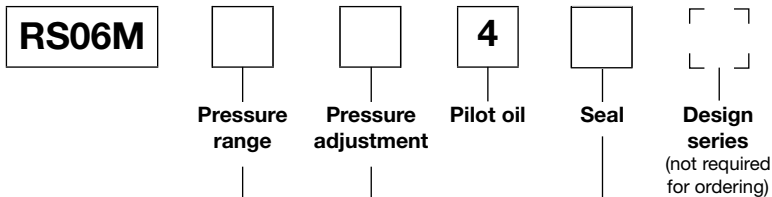

Code	Pressure range [bar]
10	105
17	175
21	210
25	250
35	350

Code	Seal
N	NBR
V	FPM

Code	Adjustment
S	Hand knob (standard)
A	Acorn nut with lead seal
L	Cylinder lock

Bold letters = Short-term availability

8

Dimensions

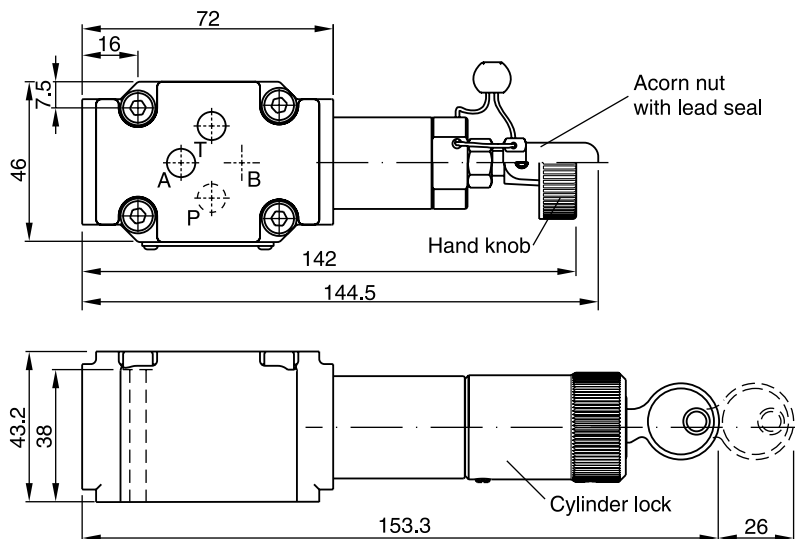

Pilot Valves

Accessories

Pilot valve with proportional relief function RPDM2*, sandwich mounting NG06. MTTF_D value 150 years, flow rate maximum 5 l/min.

*For technical details see series RE06M*W.

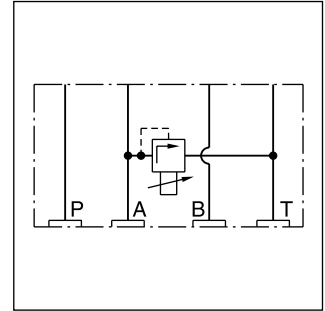

RPDM2AT

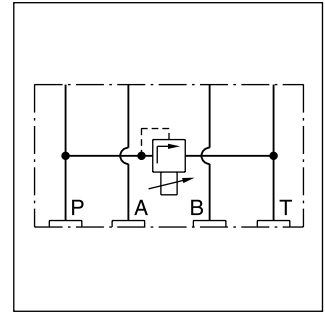

RPDM2PT

Ordering code

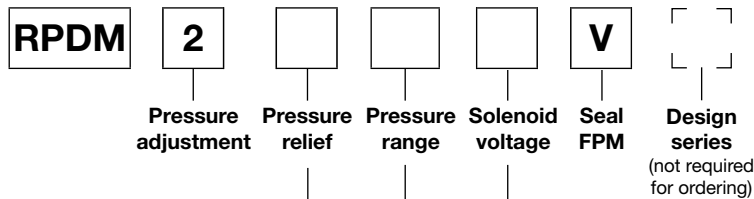

Code	Adjustment
AT	A to T
PT	P to T

Code	Solenoid voltage
K	12 V, 2.5 A
X	16 V, 1.3 A

Code	Pressure range [bar]
10	105
17	175
25	250
35	350

Bold letters = Short-term availability

Dimensions

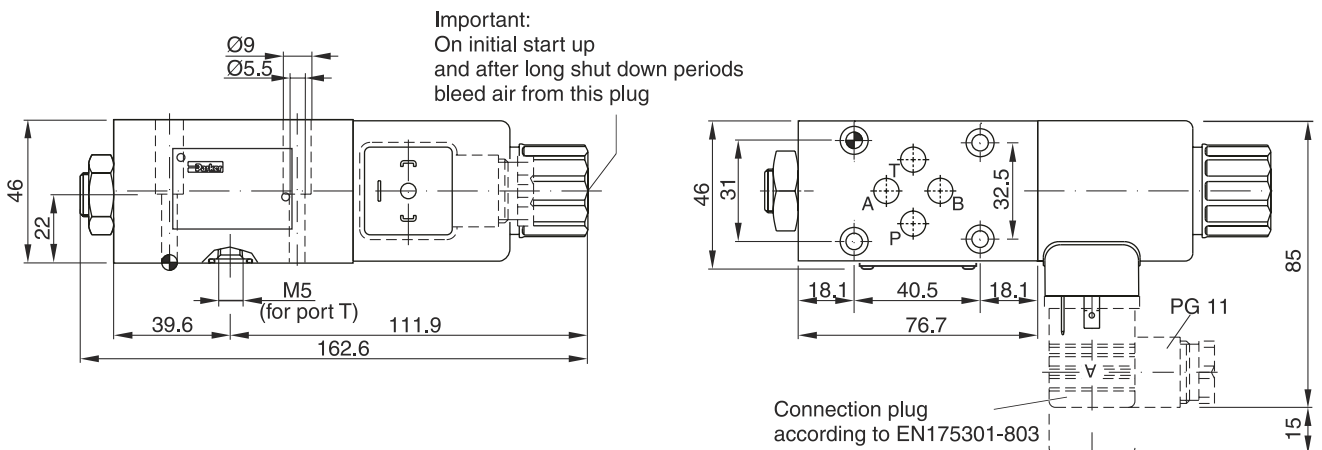

Sandwich valve with pressure relief function ZUDB, sandwich plate mounting NG06, see combination examples. MTTF_D value 150 years, flow rate maximum 5 l/min.

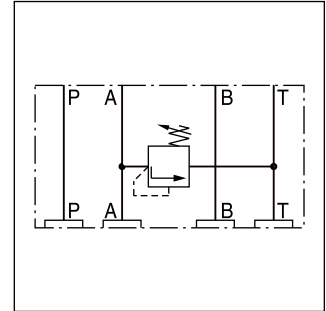

ZUDB1AT*

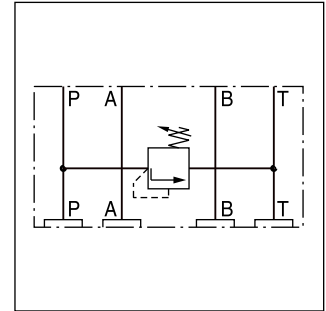

ZUDB1PT*

Ordering code

8

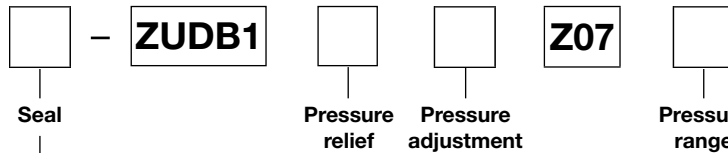

Code	Seal
omit	NBR
V	FPM

Code	Pressure relief
AT	A to T
PT	P to T

Code	Pressure range [bar]
B	70
E	175
G	250
K	350

Code	Adjustment
2	Hexagon screw with lock nut
61	Cylinder lock

**Bold letters =
 Short-term availability**

Dimensions

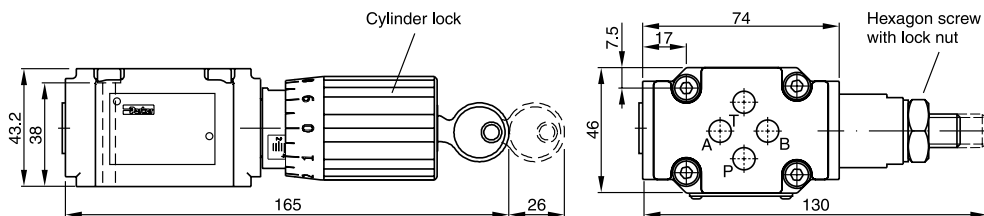

Pilot Valves

Accessories

Pilot valve with preload function DSB*P*, subplate mounting NG06, see combination examples. MTTF_D value 150 years, flow rate maximum 5 l/min.

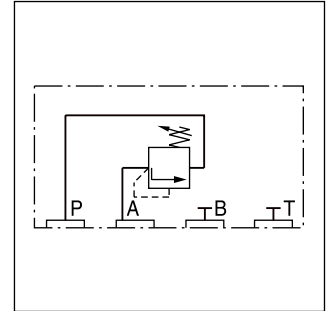

Ordering code

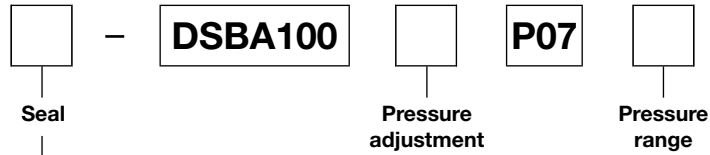

Code	Seal
omit	NBR
V	FPM

Code	Adjustment
2	Hexagon screw with lock nut
61	Cylinder lock

Code	Pressure range [bar]
B	70
E	175
G	250
K	350

Bold letters = Short-term availability

8

Dimensions

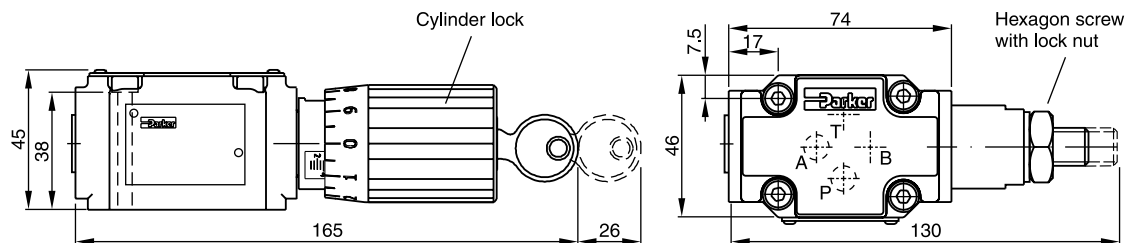

Pilot Valves

Pilot valve with preload function DSB*Z*, sandwich plate mounting NG06, see combination examples. MTTF_D value 150 years, flow rate maximum 5 l/min.

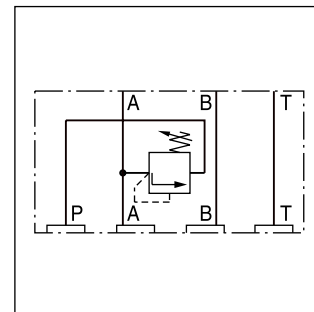

Ordering code

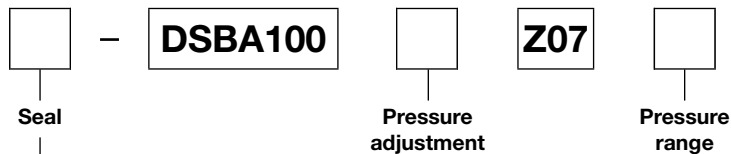

Code	Seal
omit	NBR
V	FPM

Code	Adjustment
2	Hexagon screw with lock nut
61	Cylinder lock

Code	Pressure range [bar]
B	70
E	175
G	250
K	350

8

Bold letters =
Short-term availability

Dimensions

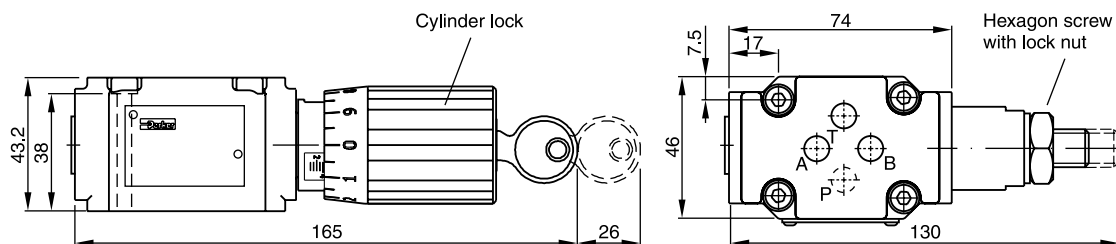

Pilot valve with unloading function UR06M, subplate mounting NG06, see combination examples. MTTFD value 150 years, flow rate maximum 5 l/min.

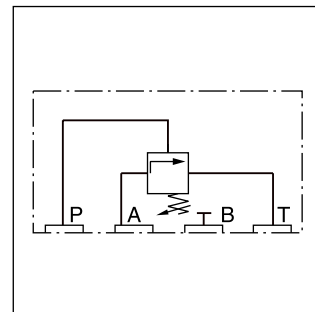

Ordering code

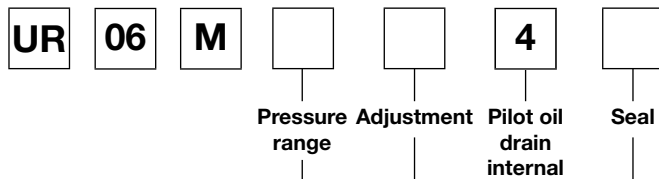

Code	Pressure range [bar]
07	70
17	175
25	250
35	350

Code	Seal
N	NBR
V	FPM

Code	Adjustment
S	Hand knob (standard)
A	Acorn nut with lead seal
L	Cylinder lock

**Bold letters =
Short-term availability**

8

Dimensions

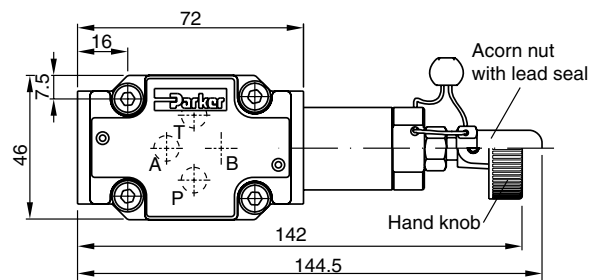
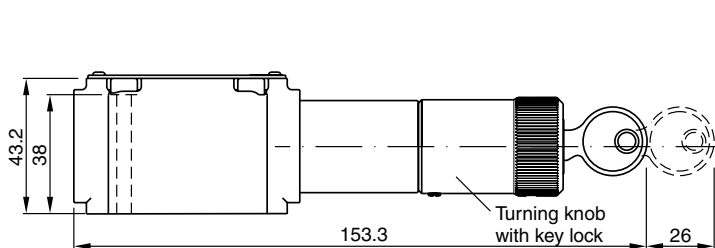

Pilot valve with unloading function US06M, sandwich plate NG06, see combination examples. $MTTF_D$ value 150 years, flow rate maximum 5 l/min.

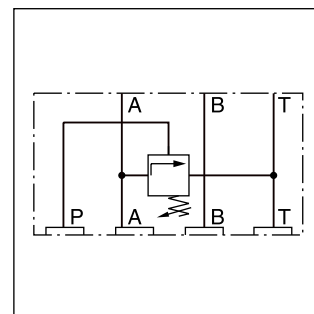

Ordering code

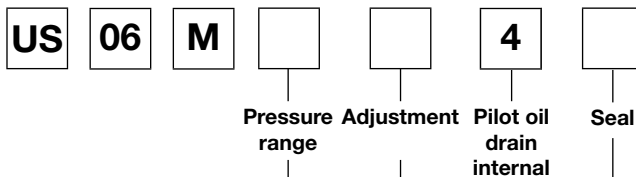

Code	Pressure range [bar]
07	70
17	175
25	250
35	350

Code	Seal
N	NBR
V	FPM

Code	Adjustment
S	Hand knob (standard)
A	Acorn nut with lead seal
L	Cylinder lock

8

**Bold letters =
 Short-term availability**

Dimensions

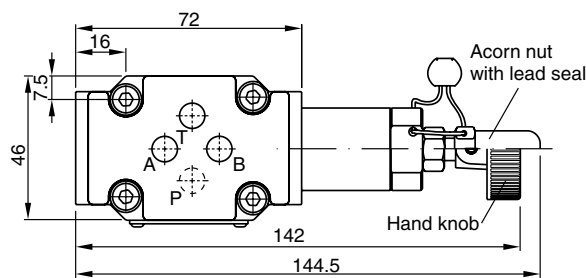
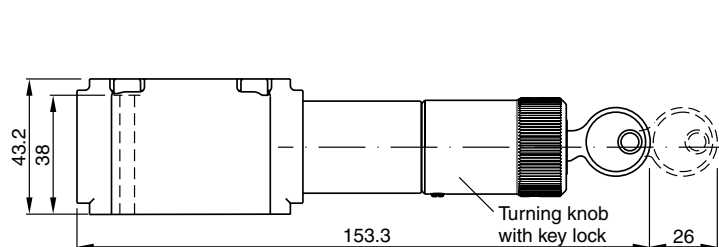

Pilot valve for pressure sequence function S06M, subplate mounting NG06, see combination examples. MTTF_D value 150 years, flow rate maximum 5 l/min.

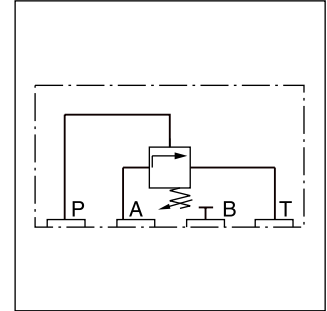

Ordering code

S06M

□

Pressure range

□

Pressure adjustment

4

Pilot oil inlet internal/
outlet internal

□

Seal

□

Design series
(not required for ordering)

Code	Pressure range [bar]
07	70
17	175
25	250
35	350

Code	Seal
N	NBR
V	FPM

Code	Adjustment
S	Hand knob (standard)
A	Acorn nut with lead seal
L	Cylinder lock

Bold letters = Short-term availability

8

Dimensions

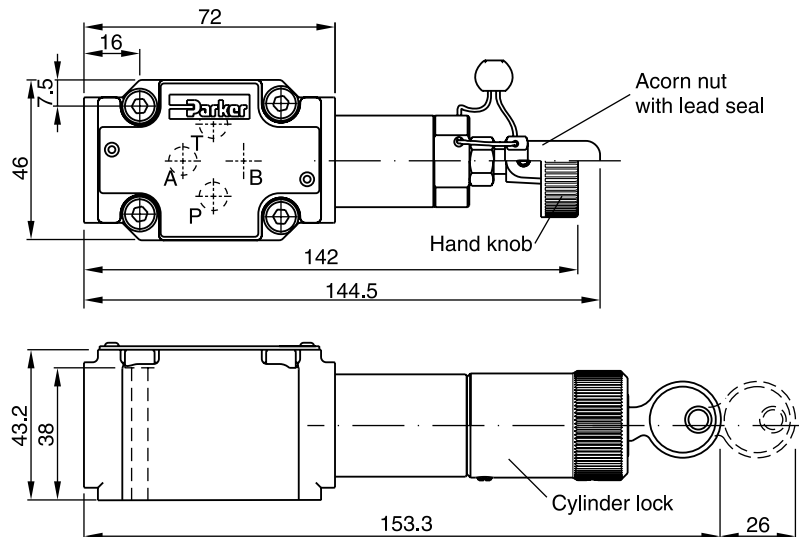

Check valve, hydraulically pilot operated NG06
 with pilot control, for subplate mounting.
 MTTF_D value 75 years, flow rate maximum 5 l/min.

Dimensions

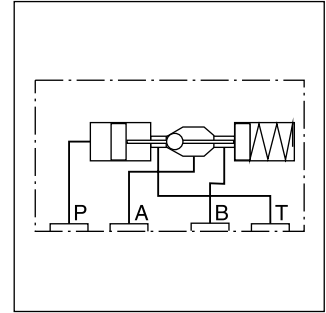
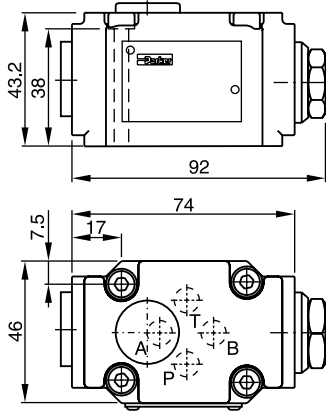

Ordering code

SVLA1006P07

Shuttle valve - sandwich plate mounting NG06
 MTTF_D value 150 years, flow rate maximum 5 l/min.

Dimensions

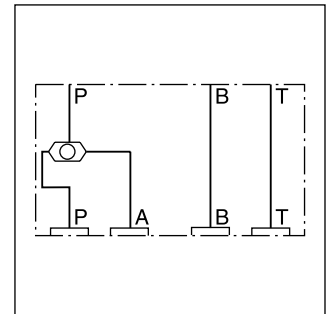
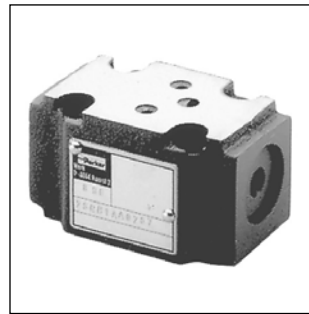
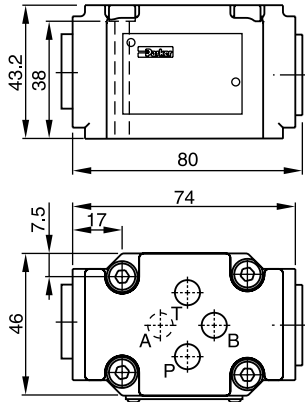

Ordering code

ZSRA1PP0Z07

Shuttle valve - sandwich plate mounting NG06
 MTTF_D value 150 years, flow rate maximum 5 l/min.

Dimensions

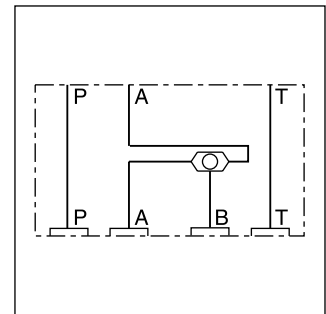
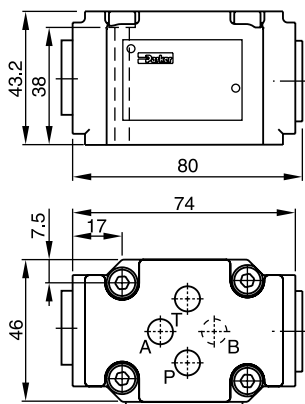

Ordering code

ZSRB1AA0Z07

8

Symbol	Type	Size	Hight
	PADA 1007-AA-BB	NG10-NG06	25
	PADA 1007/A-B/B-A	NG10-NG06	25
	H06-1044	NG06	30
	H06-1039	NG06	30
	H06-504	NG06	30
	H06-711	NG06	30
	H06-1274	NG06	30
	H06-1040	NG06	30

Attention: Details for cover-, sandwich- and adaptor plates see chapter 12.

Bold letters =
Short-term availability

Cover-, Sandwich-, Adaptor Plates

Symbol	Type	Size	Hight
	H06DO-1291	NG06	10
	H06DU-814	NG06	71.3
<p>All ports can be equipped with orifices or plugs (1/16NPT)</p>	CS06040N	NG06	40.3
<p>All ports can be equipped with orifices or plugs (1/16NPT)</p>	CS06082N	NG06	40.3
<p>All ports can be equipped with orifices or plugs (1/16NPT)</p>	CS06080N	NG06	40.3
	D51DC071D	NG06	26.3
	D51VP071C D51VP101D	NG06 NG10	26.3 26.9

Attention:
Details for cover-, sandwich- and adaptor plates see chapter 12.

Bold letters =
Short-term availability

8