

Parker Series SVLB Hydraulically Pilot Operated Check Valve Service Manual

General Description

Series SVLB hydraulically pilot operated check valves allow free flow from A to B. The counter-flow direction is blocked.

When pressure is applied to control port X, the ring chamber flow from B to A is released. The pilot control ratio is 6:1.

Function

When no pressure is applied to the X-port, the flow from B to A is blocked, because the pressure in B is also effective on top of the poppet.

Pressurizing the X-port relieves the area on top of the poppet to the drain port and allows flow from B to A.

The seat design of the SVLB valve series provides leak-free separation of port A and B in the closed position.

Features

- Pilot operated check valve.
- Cavity and mounting pattern according to ISO 7368.
- Dampening poppet optional.
- 5 sizes NG16 to NG50.

Performance Curves

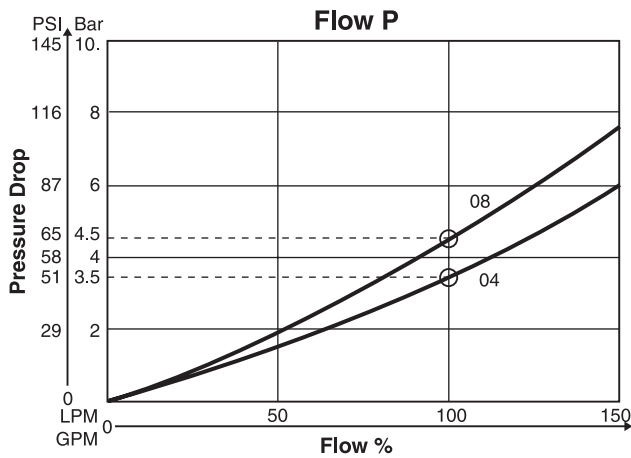

Poppet Type 04, 08, without spring

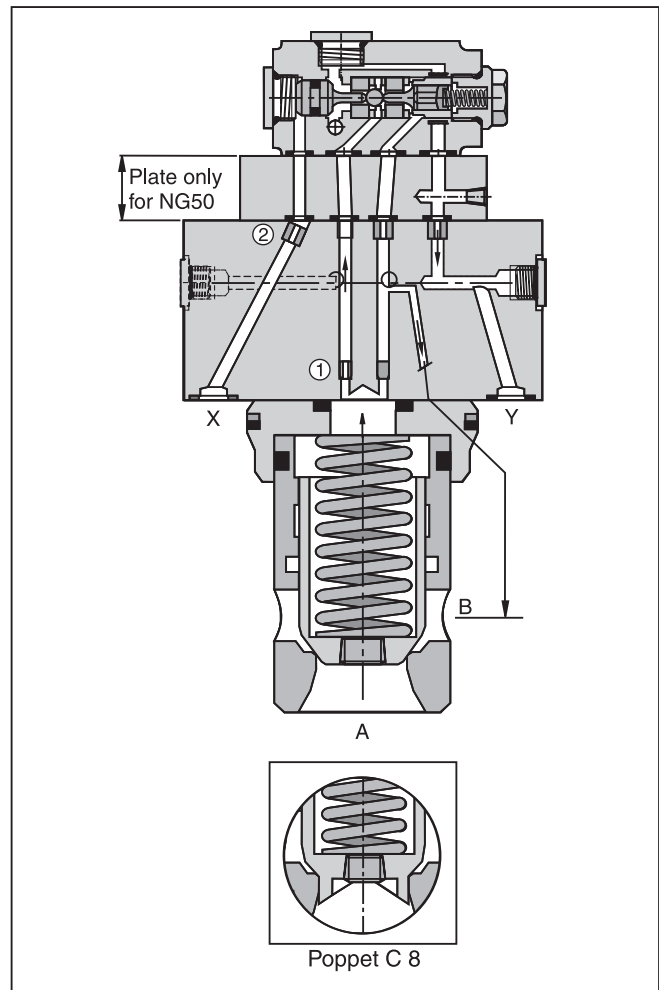
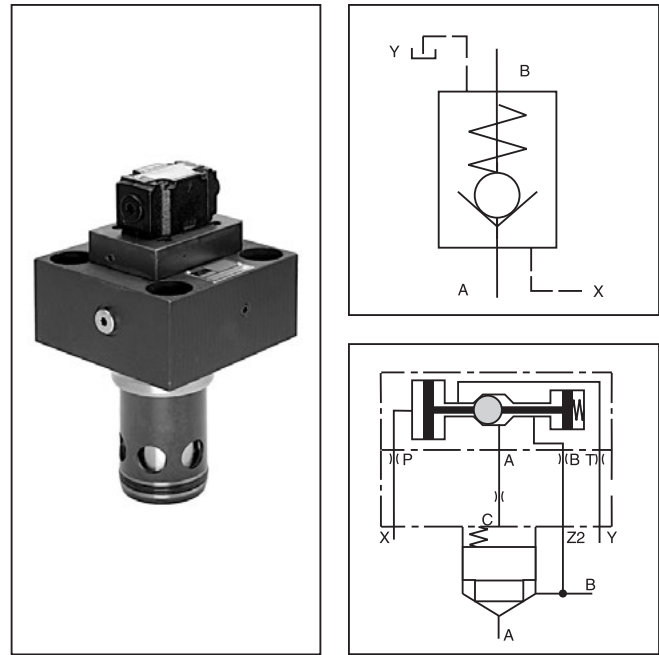

WARNING: This product can expose you to chemicals including Lead, Nickel (Metallic), or 1,3-Butadiene which are known to the State of California to cause cancer, and Lead or 1,3-Butadiene which is known to the State of California to cause birth defects and other reproductive harm. For more information go to www.P65Warnings.ca.gov.

Cat3200_02.indd, ddp, 04/19

Ordering Information

<div style="border: 1px solid black; width: 30px; height: 30px; margin: 0 auto;"></div> <p>Seals</p>	<div style="border: 1px solid black; padding: 2px; width: 40px; height: 30px; margin: 0 auto;">SVL</div> <p>Hydraulically Operated Check Valve</p>	<div style="border: 1px solid black; padding: 2px; width: 30px; height: 30px; margin: 0 auto;">B</div> <p>Slip-in Mounting</p>	<div style="border: 1px solid black; padding: 2px; width: 40px; height: 30px; margin: 0 auto;">10</div> <p>Design Style according to ISO 7368</p>	<div style="border: 1px solid black; width: 30px; height: 30px; margin: 0 auto;"></div> <p>Poppet Type</p>	<div style="border: 1px solid black; padding: 2px; width: 40px; height: 30px; margin: 0 auto;">6</div> <p>Pilot Control Ratio 6:1</p>	<div style="border: 1px solid black; padding: 2px; width: 40px; height: 30px; margin: 0 auto;">E</div> <p>Slip-in Cartridge Valve</p>	<div style="border: 1px solid black; width: 30px; height: 30px; margin: 0 auto;"></div> <p>Valve Size</p>	<div style="border: 1px solid black; width: 30px; height: 30px; margin: 0 auto;"></div> <p>Closing Spring</p>	<div style="border: 1px dashed black; width: 40px; height: 40px; margin: 0 auto; display: flex; align-items: center; justify-content: center;"> { } </div> <p>Design Series</p> <p>NOTE: Not required when ordering.</p>
--	--	--	---	--	---	---	---	---	---

Code	Description
	Nitrile
V	Fluorocarbon

Code	Description
4	04
8 ¹⁾	08

¹⁾ with damping nose

Code	Description
16	NG16
25	NG25
32	NG32
40	NG40
50	NG50

Code	Description
N	0.5 Bar (7.3 PSI)
S	1.6 Bar (23.2 PSI)
T	2.5 Bar (36.3 PSI)
U	4.0 Bar (58.0 PSI)

Weight:

SVLB16	2.3 kg (5.1 lbs.)
SVLB25	3.2 kg (7.1 lbs.)
SVLB32	4.6 kg (10.1 lbs.)
SVLB40	7.8 kg (17.2 lbs.)
SVLB50	12.0 kg (26.5 lbs.)

Specifications

General						
Size		NG16	NG25	NG32	NG40	NG50
Interface	Slip-in mounting, according to ISO 7368					
Mounting Position	Unrestricted					
Ambient Temperature	-20°C to +80°C (-4°F to +176°F)					
Hydraulic						
Maximum Operating Pressure	350 Bar (5075 PSI)					
Nominal Flow	LPM	250	450	900	1300	1800
	GPM	(66)	(119)	(238)	(344)	(476)
Fluid	Hydraulic oil according to DIN 51524 ... 525					
Viscosity Recommended	30 to 50 cSt (mm ² /s)					
Viscosity Permitted	20 to 380 cSt (mm ² /s)					
Fluid Temperature	-20°C to +70°C (-4°F to +158°F)					
Filtration	ISO 4406 (1999); 18/16/13 (meet NAS 1638:7)					

Standard Orifices

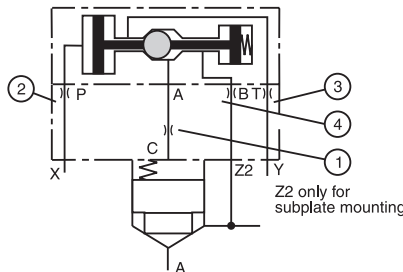

Position	E16	E25	E32	E40	E50
1	open (M5)	open (M5)	open (M5)	open (M5)	open (M6)
2	Ø1.2 (M5)	Ø1.2 (M6)	Ø1.2 (M6)	Ø1.2 (M6)	Ø1.2 (M8)
3	open (M5)	open (M6)	open (M6)	open (M6)	open (M8)
4	Ø1.0 (M5)	Ø1.2 (M6)	Ø1.3 (M6)	Ø1.5 (M6)	Ø2.0 (M8)

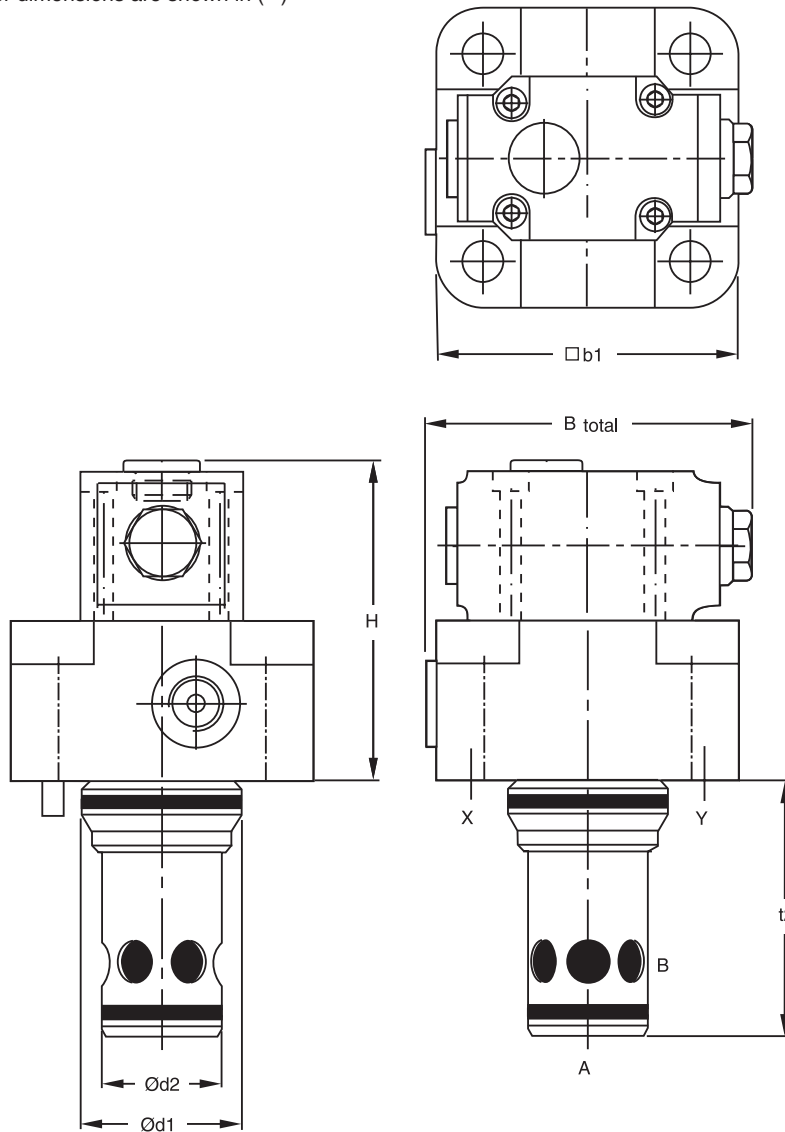

Dimensions

Inch equivalents for millimeter dimensions are shown in (**)



Size	NG16	NG25	NG32	NG40	NG50
H	84.0 (3.31)	88.0 (3.46)	93.0 (3.66)	103.0 (4.06)	138.0 (5.43)
b1	79.0* (3.11)	85.0 (3.35)	102.0 (4.02)	125.0 (4.92)	140.0 (5.51)
d1 ^{H7}	32.0 (1.26)	45.0 (1.77)	60.0 (2.36)	75.0 (2.95)	90.0 (3.54)
d2 ^{H7}	25.0 (0.98)	34.0 (1.34)	45.0 (1.77)	55.0 (2.17)	68.0 (2.68)
t2 ^{+0.1}	56.0 (2.20)	72.0 (2.83)	85.0 (3.35)	105.0 (4.13)	122.0 (4.80)
Bges.	99.0 (3.90)	94.0 (3.70)	103.0 (4.06)	125.0 (4.92)	140.0 (5.51)

¹⁾ Width 65mm (2.56 in.)

NG	Bolt Kit - 		Kit 	
			Nitrile	Fluorcarbon
16	BK414 (BK84)	33 Nm (24.3 lb.-ft.)	SK-SVLB10-E16	SK-SVLB10-E16V
25	BK391 (BK77)	115 Nm (54.8 lb.-ft.)	SK-SVLB10-E25	SK-SVLB10-E25V
32	BK415 (BK85)	281 Nm (207.2 lb.-ft.)	SK-SVLB10-E32	SK-SVLB10-E32V
40	BK416 (BK86)	553 Nm (407.8 lb.-ft.)	SK-SVLB10-E40	SK-SVLB10-E40V
50	BK417 (BK87)	553 Nm (407.8 lb.-ft.)	SK-SVLB10-E50	SK-SVLB10-E50V