

Parker Series TPQ 3-Way High-Response Valve Service Manual

General Description

Series TPQ 3/2 way, proportional throttle valves are used in applications where high flow has to be precisely controlled at maximum dynamics. Typical applications are die casting, injection molding and hydraulic presses.

Function

The TPQ valve has a 2-stage design consisting of a DFplus pilot valve and a main stage with spool and LVDT.

With the DFplus pilot valve the TPQ achieves extremely fast response times: from 9ms (NG32) up to 23ms (NG80) with an accuracy of <0.1% of the nominal flow. The pilot valve actively controls the poppet independent of the pressure conditions in the main ports.

It is basically required that the pilot pressure is at the level of the system pressure. At low system pressure the pilot pressure should be min. 140 Bar (2030 PSI), when high valve dynamics are desired.

The TPQ has integrated electronics controlling both the position of the main poppet and the spool position of the DFplus pilot valve.

TPQ040

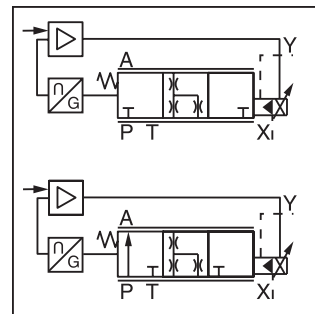
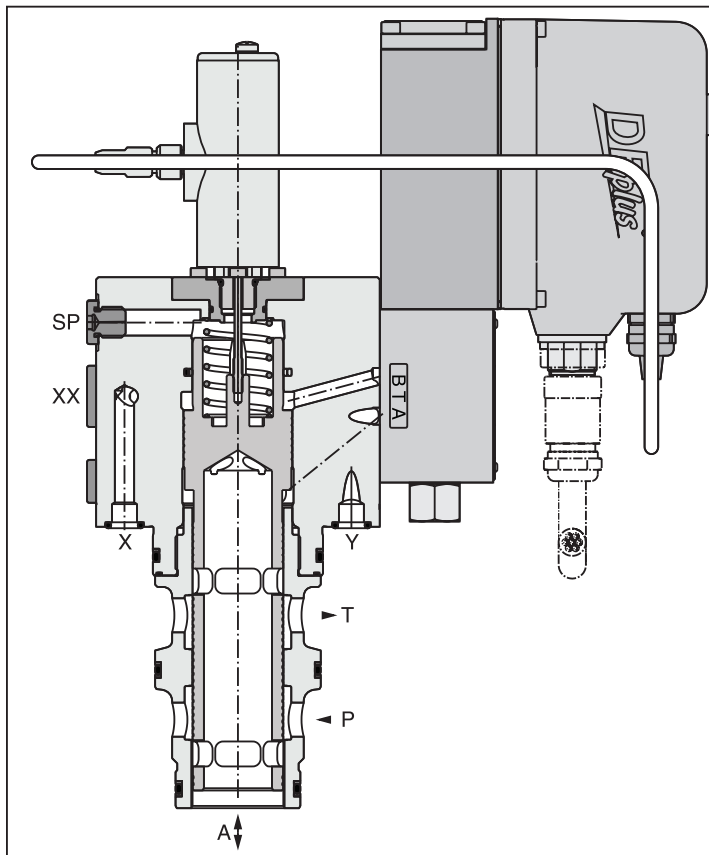

Features

- Active pilot operated 3/2 way proportional throttle valve.
- Cavity according to Parker house norm.
- Mounting pattern according to ISO 7368.
- Fast step response.
- Flow direction A to T and P to A.
- Completely mounted and adapted unit with integrated electronics.
- Fail save position in case of electrical and/or hydraulic power down.
- 5 sizes NG32 up to NG80.

Failsafe Position:



Zero Position:



Function Symbol
Failsafe Position Spool Type U

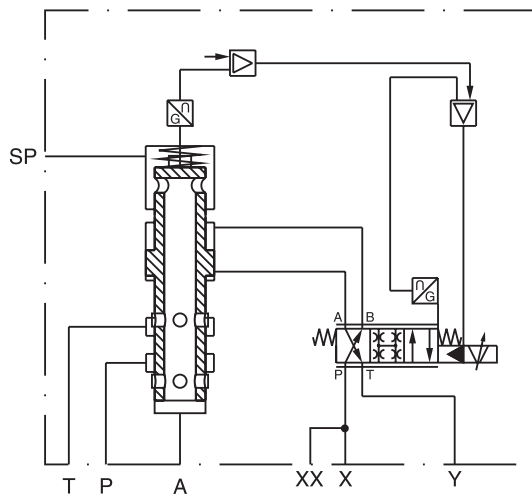

WARNING: This product can expose you to chemicals including Lead, Nickel (Metallic), or 1,3-Butadiene which are known to the State of California to cause cancer, and Lead or 1,3-Butadiene which is known to the State of California to cause birth defects and other reproductive harm. For more information go to www.P65Warnings.ca.gov.

Cat3200_02.indd, ddp, 04/19

Ordering Information

TPQ		W	H	2	5		2			0	
Proportional Throttle Valve with LVDT	Nominal Size	Parker Slip-in Cartridge	Closed Pilot Loop, Fast Valve Type, Integrated Electronics	Linear Spool	Nominal Flow	Spool Type	Pilot Oil Supply External Drain External	Seal	Input Signal	Standard Electronics	Design Series NOTE: Not required when ordering.

Code	Description
032	NG32
040	NG40
050	NG50
063	NG63
080	NG80

Zerolap		
Code	Spool Type	Fail save
	Input signal	
	- 0 +	
R		P to A
U		A to T

Code	Description
B	0...±10V
S	4...+20mA

Code	Description
N	NBR
V	FPM
H	For HFC Fluid

Please order connector separately.

Weight:

TPQ032	13.0 kg (28.7 lbs.)
TPQ040	15.0 kg (33.1 lbs.)
TPQ050	26.0 kg (57.3 lbs.)
TPQ063	52.0 kg (114.6 lbs.)
TPQ080	105.0 kg (231.5 lbs.)

Performance Curves

Flow / Signal Line

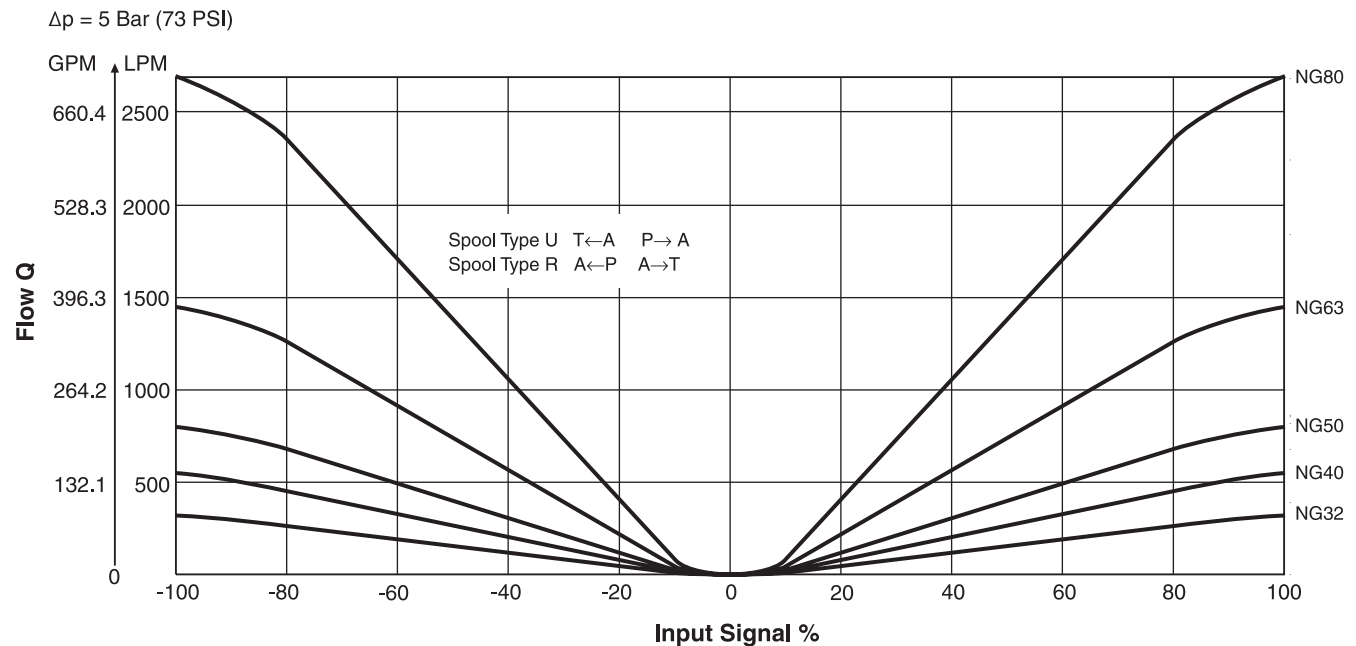

Flow at different Δp $Q_{\text{actual}} = Q_{\text{nominal}} \cdot \sqrt{\frac{\Delta p_{\text{actual}}}{\Delta p_{\text{nominal}}}}$

Characteristic curve measured with HLP46 at 50°C (122°F).

Specifications

General						
Size		NG32	NG40	NG50	NG63	NG80
Interface	Proportional Throttle Valve, Slip-in Cartridge according to ISO 7368					
Mounting Position	Unrestricted					
Ambient Temperature	-20°C to +50°C (-4°F to +122°F)					
MTTF _D	50 years					
Vibration Resistance	g	10 sinus 5...2000 Hz acc. IEC 68-2-6 30 random noise 20...2000 Hz acc. IEC 68-2-36 15 shock acc. IEC 68-2-27				
Hydraulic						
Maximum Operating Pressure	Ports A, P, T, X, XX ¹⁾ and SP ¹⁾ , up to 350 Bar (5075 PSI), Port Y, maximum 35 Bar (507.5 PSI)					
Nominal Flow $\Delta p = 5 \text{ Bar (72.5 PSI)}$	LPM GPM	320 (84.5)	550 (145.3)	800 (211.3)	1450 (383.0)	2700 (713.3)
Maximum Flow Recommended	LPM GPM	1000 (264.2)	1600 (422.7)	2250 (594.4)	3500 (924.6)	6500 (1717.1)
Fluid	Hydraulic oil according to DIN 51524...51525					
Fluid Temperature	0°C to +60°C (+32°F to +140°F)					
Viscosity Recommended	30 to 80 cSt (mm ² /s)					
Viscosity Permitted	20 to 380 cSt (mm ² /s)					
Filtration	ISO 4406 (1999); 18/16/13 (meet NAS 1638:7)					
Nominal Overlap	< 1.5%					
Flow Direction	A to T and P to A					
Pilot Pressure	Must be as high as system pressure					
Pilot Oil Supply	External via X					
Pilot Oil Drain	External via Y					
Leakage in Pilot Valve at 100 Bar (1450 PSI)	<400 LPM (105.7 GPM)					
Leakage in Main Stage at 100 Bar (1450 PSI)	NG32 to 63 <2.5 LPM (0.7 GPM); NG80 <4.0 LPM (1.06 GPM)					
Pilot Valve Size	NG6			NG10		
Maximum Pilot Flow at 140 Bar (2030 PSI) Pilot Press.		25 LPM (6.6 GPM)	25 LPM (6.6 GPM)	25 LPM (6.6 GPM)	50 LPM (13.2 GPM)	60 LPM (15.9 GPM)
Static / Dynamic ²⁾						
Step Response at Pilot Pressure >140 Bar (2030 PSI)		9 ms	11 ms	18 ms	15 ms	23 ms
Frequency Resp. at Pilot Press. >140 Bar (2030 PSI) Amplitude -3dB; 10% ±5% Phase -90°; ±5%		105 Hz 90 Hz	95 Hz 82 Hz	54 Hz 72 Hz	30 Hz 62 Hz	34 Hz 56 Hz
Hysteresis	< 1%					
Sensitivity	< 0.05%					
Temperature Drift of Center Position	< 0.025%K					

1) Suction port SP and accu port XX: Please contact Parker for installation recommendation.

2) For optimal dynamics see installation recommendation.

(Continued on next page)

Specifications

Specifications (Continued from previous page)

Electrical	
Duty Ratio	100% ED
Protection Class	IP65 in accordance with EN 60529 (with correctly mounted plug-in connector)
Supply Voltage / Ripple	22...30V, ripple < 5% eff., surge free
Current Consumption Max.	3.5 A
Pre-fusing	4.0 A medium lag
Input Signal Voltage Impedance Input Capacitance Typ.	+10...0...-10, ripple < 0.01% eff., surge free 100 kOhm 1 nF
Current	4...12...20 mA, ripple < 0.01% eff., surge free < 3.6 mA = enable off, > 3.8 mA = enable on acc. NAMUR NE43
Impedance	250 Ohm
Differential Input Maximum	30V for terminal D and E against PE (terminal G), 11V for terminal D and E against 0V (terminal B)
Enable Signal	5...30V, Ri = 9 kOhm
Diagnostic Signal	0...+10V, rated max. 5mA
EMC	EN 61000-6-2, EN 61000-6-4
Electrical Connection	6 + PE as per EN 175201-804
Wiring Minimum mm ²	7 x 1.0 (AWG16) overall braid shield
Wiring Length Maximum	50 m (164 ft.)

Block Diagram — Wiring

Block Diagram

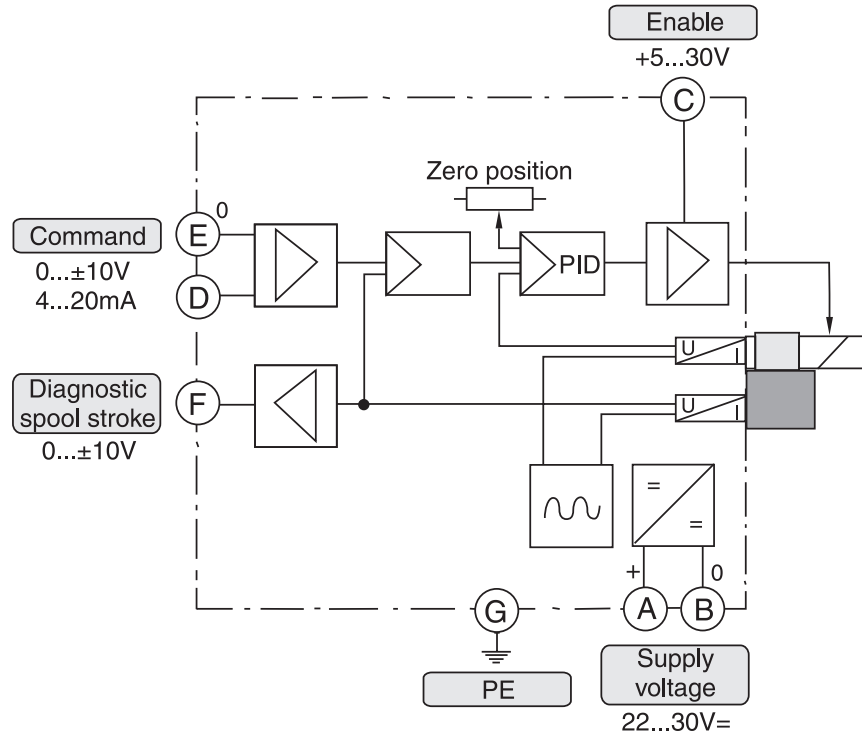

Wiring Connections Electronics Code B

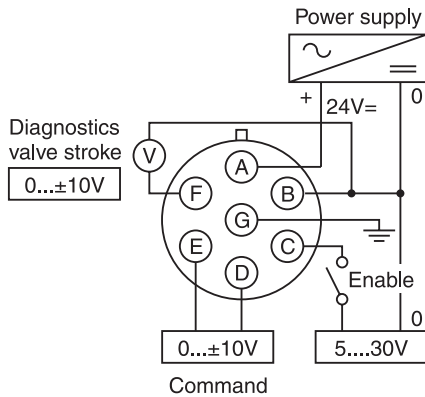

Electronics Code S

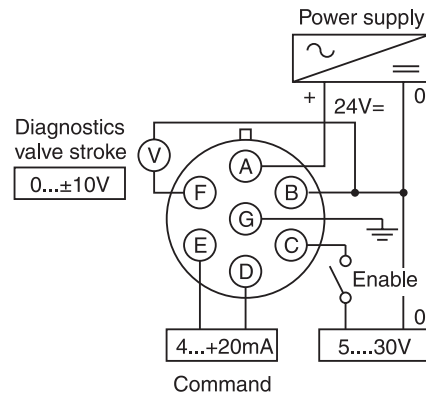

Female Connector (EMC conforming)

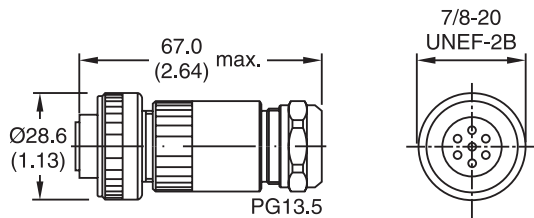

Part No. 5004072

Please order plugs separately.

Angle Female Connector (EMC conforming)

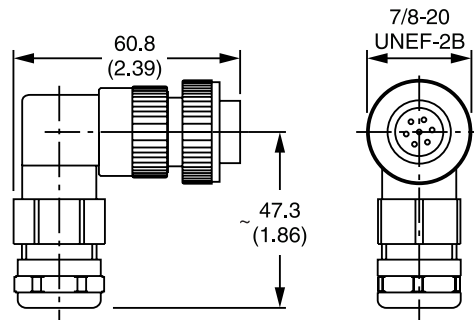

Part No. 5005160

Dimensions

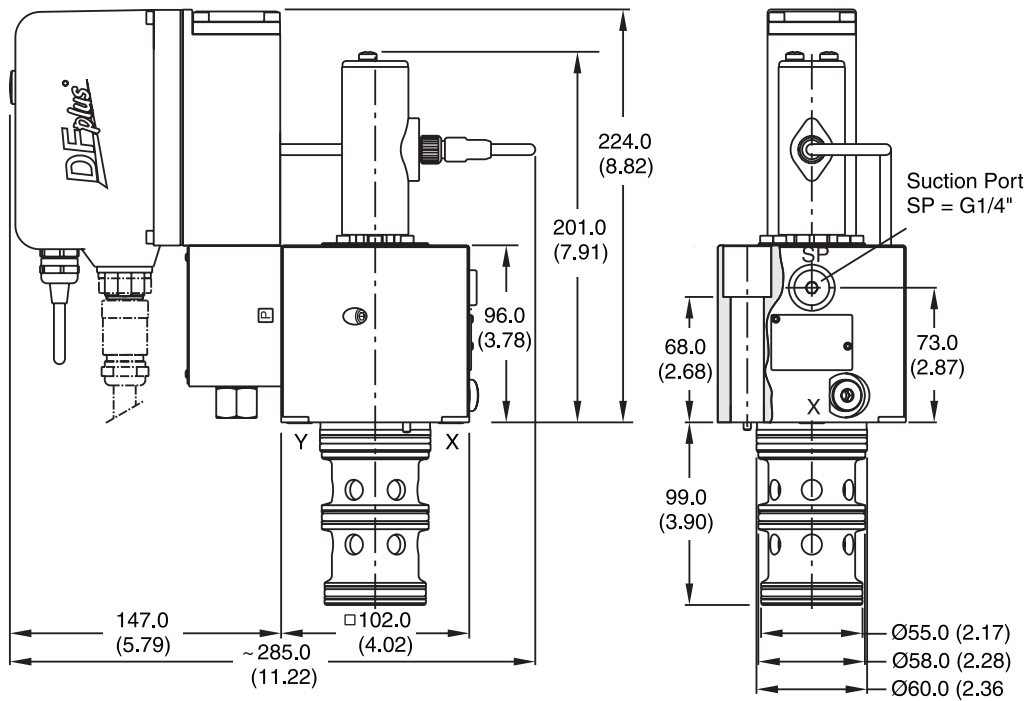

Inch equivalents for millimeter dimensions are shown in (**)

NG32

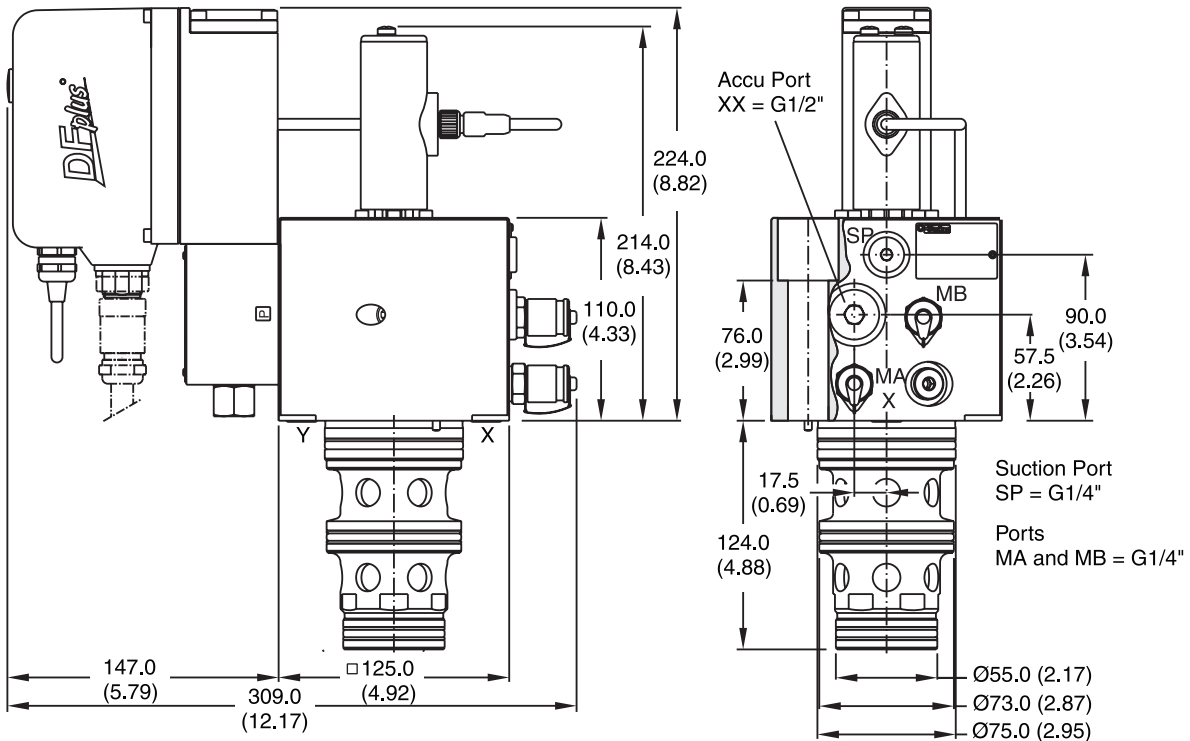

NG40







NG	Bolt Kit - 		Kit 	
			Nitrile	Fluorocarbon
32	BK529 4x M16x100 DIN 912 12.8	281 Nm (207.2 lb.-ft.)	SK-TPQ032EN	SK-TPQ032EV
40	BK513 4 x M20x120 DIN 912 12.8	553 Nm (407.8 lb.-ft.)	SK-TPQ040EN	SK-TPQ040EV

Dimensions

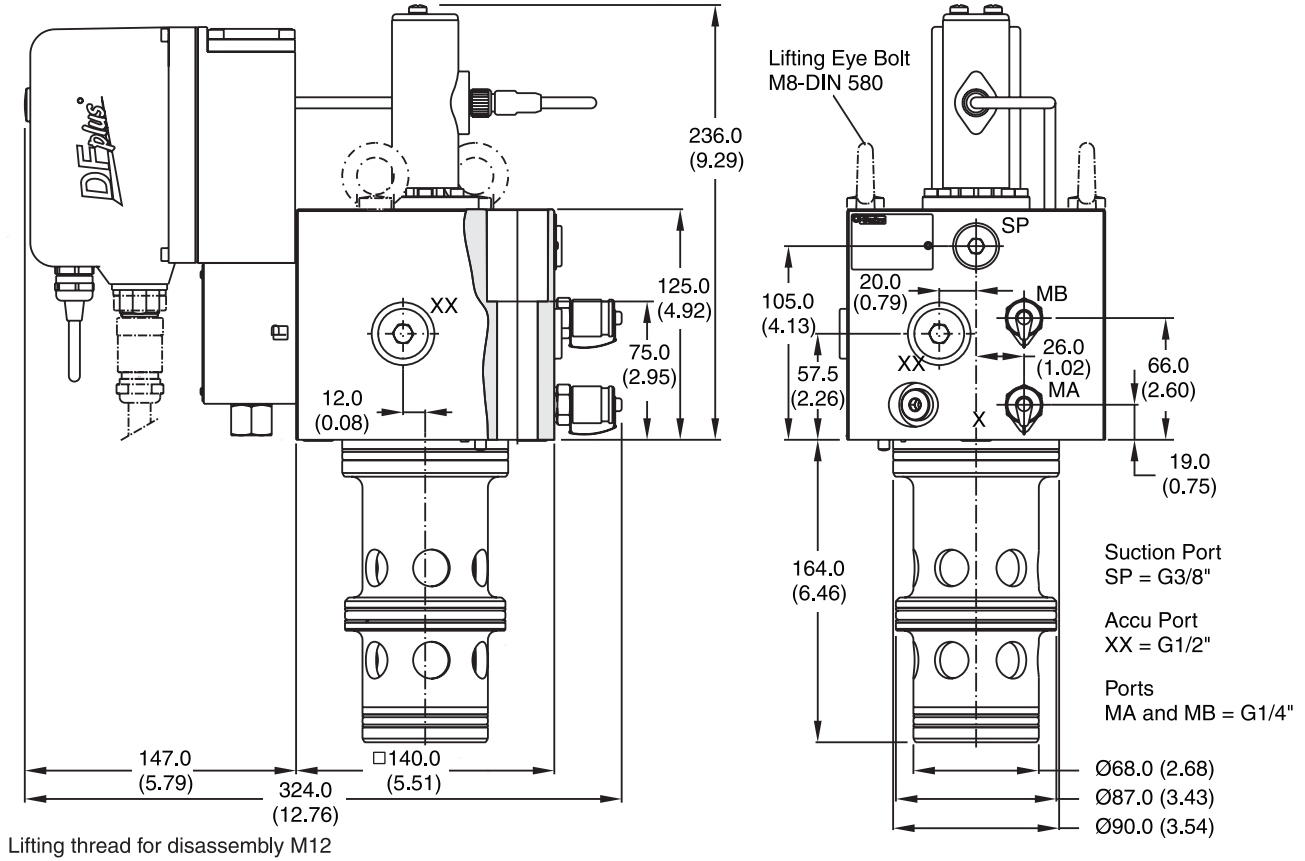
Inch equivalents for millimeter dimensions are shown in (**)

NG50



NG	Bolt Kit - 		Nitrile 	Kit	Fluorocarbon
50	BK513 4 x M20x120 DIN 912 12.8	553 Nm (407.8 lb.-ft.)	SK-TPQ050EN		SK-TPQ050EV



Dimensions

Inch equivalents for millimeter dimensions are shown in (**)

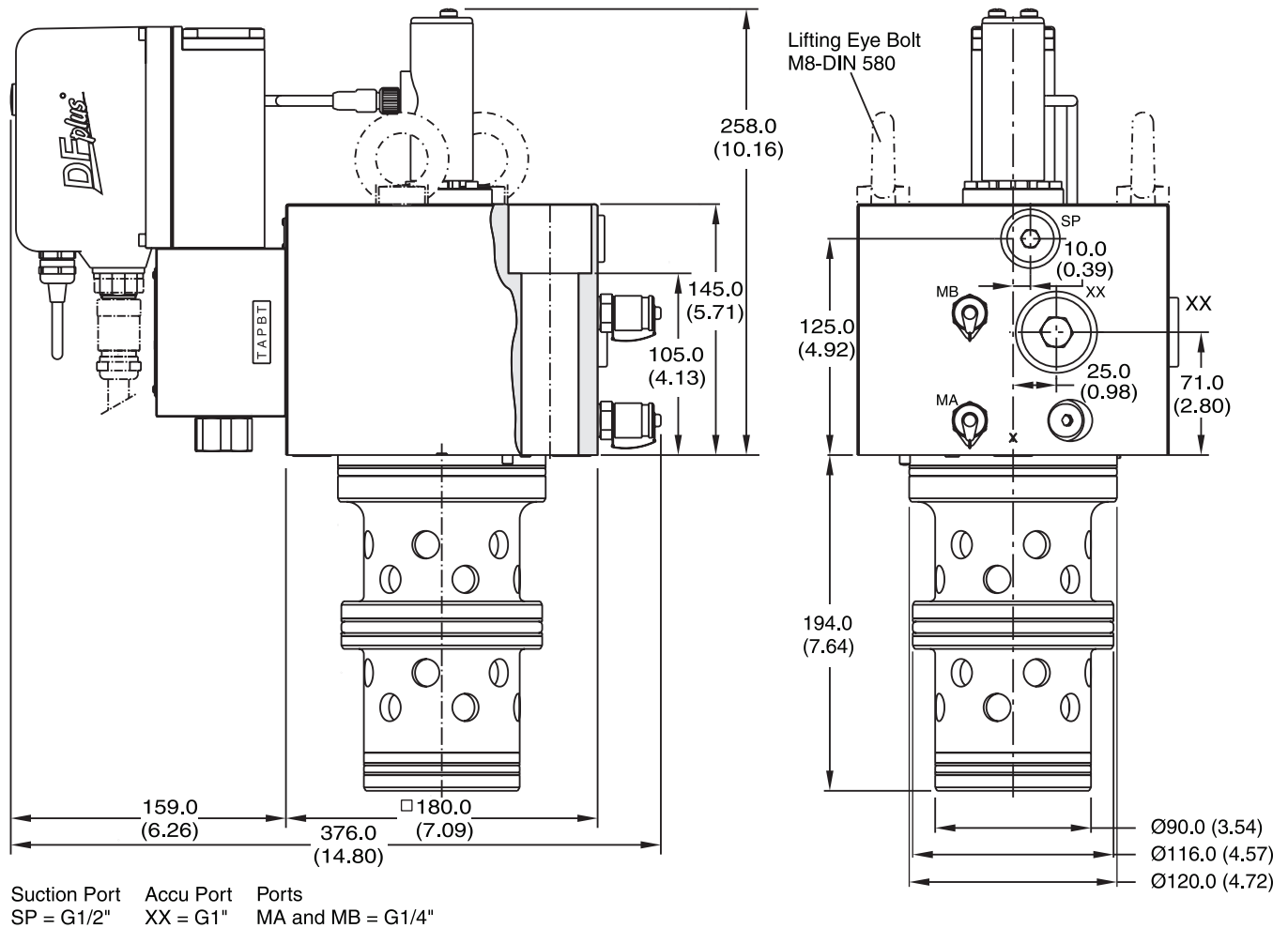
NG63



Lifting Thread for Disassembly M12

NG	Bolt Kit -  DIN912 12.9		Nitrile	Kit
63	BK420 4x M30x140 DIN 912 12.9	1910 Nm (1408.6 lb.-ft.)	SK-TPQ063EN	Fluorocarbon SK-TPQ063EV



Dimensions

Inch equivalents for millimeter dimensions are shown in (**)

NG80

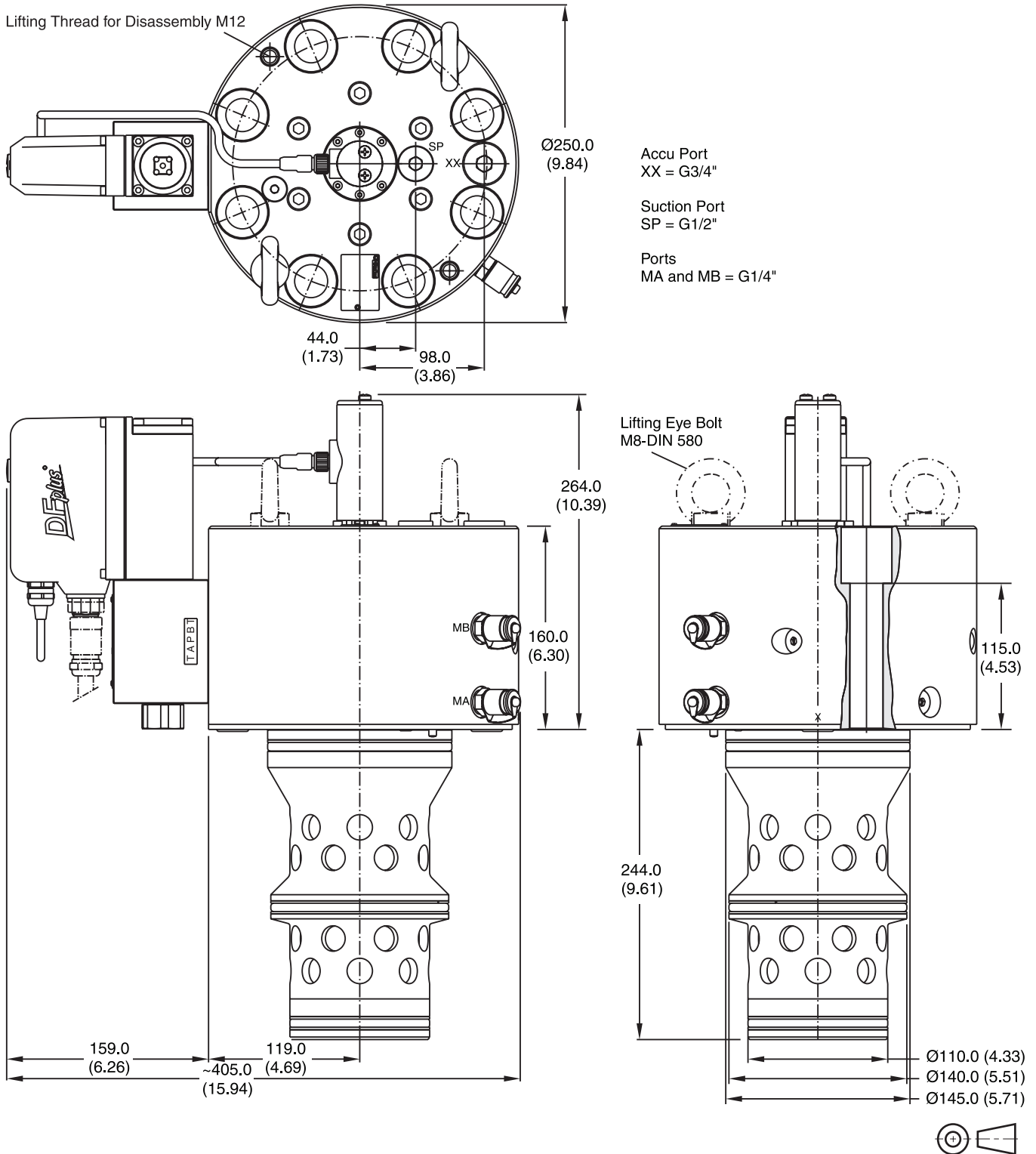
Lifting Thread for Disassembly M12



NG	Bolt Kit -  DIN912 12.9		Nitrile	Kit
80	BK530 8x M24x160 DIN 912 12.9	955 Nm (704.3 lb.-ft.)	SK-TPQ080EN	Fluorocarbon SK-TPQ080EV

Dimensions

NG32 to NG63

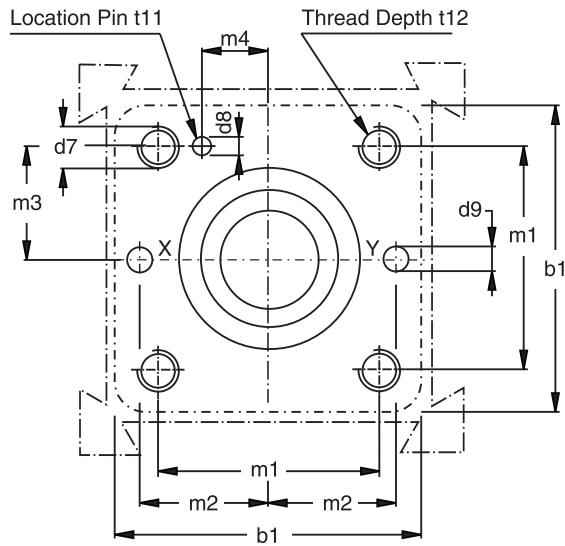

NG80

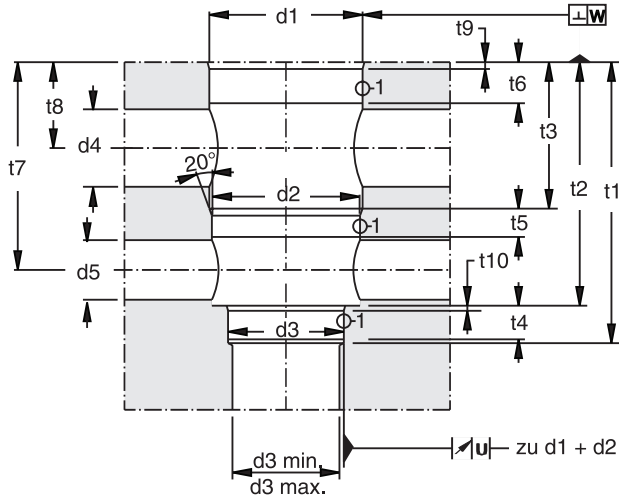
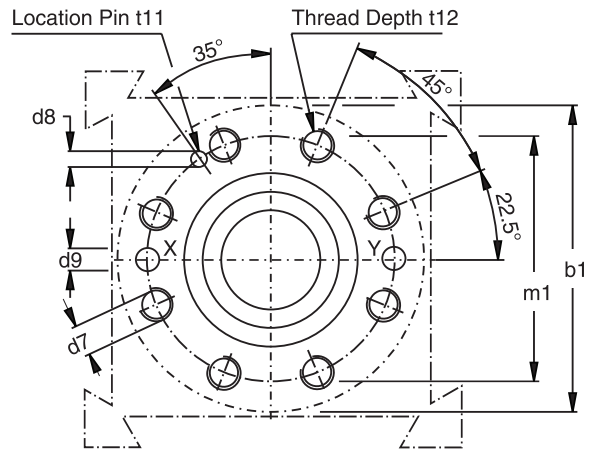

Required surface finish:

$$\sqrt{R_{\max} 25}, \textcircled{1} = \sqrt{R_{\max} 8}$$

Dimensions

Inch equivalents for millimeter dimensions are shown in (**)

Size	b1	d1 H7	d2 H7	d3 H7	d3 min.	d3 max.	d4	d5	d7	d8 H13	d9
32	102.0 (4.02)	60.0 (2.36)	58.0 (2.28)	55.0 (2.17)	32.0 (1.26)	54.0 (2.13)	28.0 (1.10)	28.0 (1.10)	M 16	6.0 (0.24)	8.0 (0.31)
40	125.0 (4.92)	75.0 (2.95)	73.0 (2.87)	55.0 (2.17)	40.0 (1.57)	54.0 (2.13)	38.0 (1.50)	32.0 (1.26)	M 20	6.0 (0.24)	10.0 (0.39)
50	140.0 (5.51)	90.0 (3.54)	87.0 (3.43)	68.0 (2.68)	50.0 (1.97)	67.0 (2.64)	63.0 (2.48)	38.0 (1.50)	M 20	8.0 (0.31)	10.0 (0.39)
63	180.0 (7.09)	120.0 (4.72)	116.0 (4.57)	90.0 (3.54)	63.0 (2.48)	89.0 (3.50)	64.0 (2.52)	52.0 (2.05)	M 30	8.0 (0.31)	12.0 (0.47)
80	250.0 (9.84)	145.0 (5.71)	140.0 (5.51)	110.0 (4.33)	80.0 (3.15)	109.0 (4.29)	70.0 (2.76)	66.0 (2.60)	M 24	10.0 (0.39)	16.0 (0.63)

Size	m1 ±0.2	m2 ±0.2	m3 ±0.2	m4 ±0.2	t1 ⁺³ +1	t2 ±0.2	t3 ±0.2	t4	t5	t6	t7 ±0.2	t8 ±0.2	t9	t10	t11	t12
32	70.0 (2.76)	41.0 (1.61)	35.0 (1.38)	17.0 (0.67)	100.0 (3.94)	85.0 (3.35)	43.0 (1.69)	13.5 (0.53)	16.0 (0.63)	18.0 (0.71)	71.0 (2.80)	28.5 (1.12)	2.5 (0.10) x15°	2.5 (0.10) x15°	10.0 (0.39)	35.0 (1.38)
40	85.0 (3.35)	50.0 (1.97)	42.5 (1.67)	23.0 (0.91)	125.0 (4.92)	105.0 (4.13)	54.0 (2.13)	15.0 (0.59)	18.0 (0.71)	21.0 (0.83)	88.0 (3.46)	34.0 (1.34)	3.0 (0.12) x15°	3.0 (0.12) x15°	10.0 (0.39)	45.0 (1.77)
50	100.0 (3.94)	58.0 (2.28)	50.0 (1.97)	30.0 (1.18)	165.0 (6.50)	143.0 (5.63)	86.0 (3.39)	22.0 (0.87)	18.0 (0.71)	21.0 (0.83)	122.0 (4.80)	53.0 (2.09)	4.0 (0.16) x15°	3.0 (0.12) x15°	10.0 (0.39)	45.0 (1.77)
63	125.0 (4.92)	75.0 (2.95)	62.5 (2.46)	38.0 (1.50)	195.0 (7.68)	165.0 (6.50)	83.5 (3.29)	20.0 (0.79)	29.5 (1.16)	33.0 (1.30)	138.5 (5.45)	50.0 (1.97)	4.0 (0.16) x15°	4.0 (0.16) x15°	10.0 (0.39)	65.0 (2.56)
80	200.0 (7.87)	—	—	—	245.0 (9.65)	215.0 (8.46)	123.0 (4.84)	25.0 (0.98)	27.0 (1.06)	60.0 (2.36)	181.0 (7.13)	87.0 (3.43)	5.0 (0.20) x15°	5.0 (0.20) x15°	10.0 (0.39)	50.0 (1.97)