

Parker Series VB Direct Operated Pressure Relief Valve Service Manual

Direct operated pressure relief valve with manual adjustment. The series VB can also be used as a pressure sequence valve, because of the high pressure capability in the outlet port and the external drain port.

Features

- Spool type valve
- Subplate mounting according to ISO 5781
- 5 pressure stages at NG06
- 3 pressure stages at NG10
- 2 adjustment modes



VB*A10

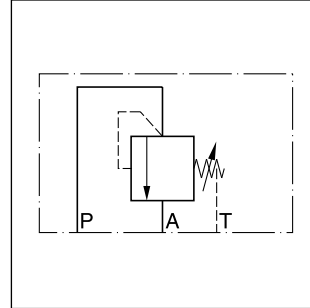

VB*A06

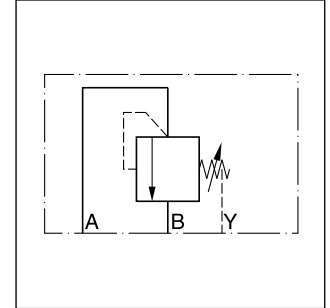

VB*A10

VB*A06

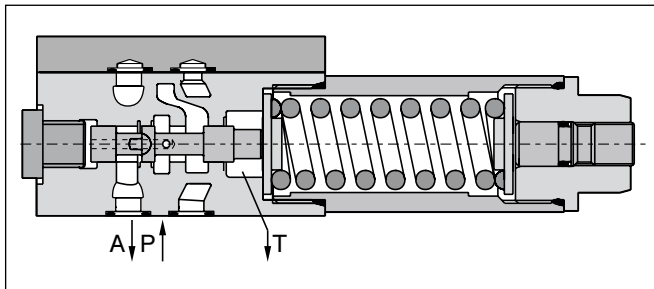

VB*A10

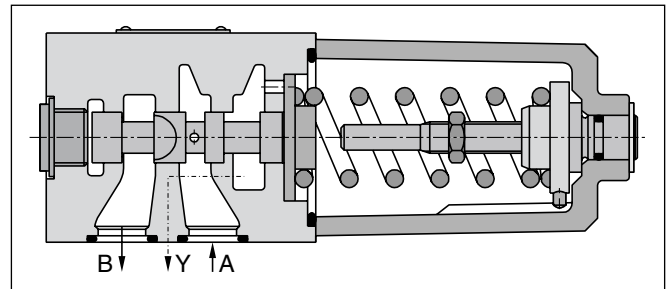

Ordering code

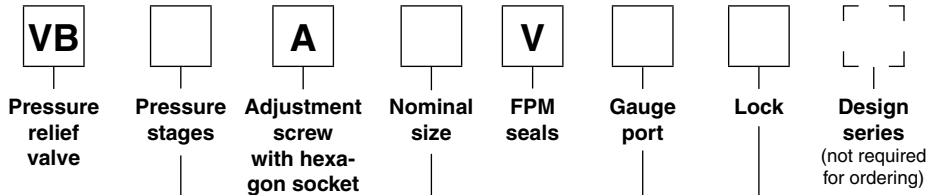

Code	Pressure stages
025 ¹⁾	up to 25 bar
064	up to 64 bar
125 ²⁾	up to 125 bar
160 ¹⁾	up to 160 bar
210	up to 210 bar
350 ¹⁾	up to 350 bar

Code	Lock
omit	—
Z	Cylinder lock

Code	Nominal size
06	NG06
10	NG10

Code	Gauge port
G ¹⁾	G 1/4"
M ²⁾	M18x1.5

Bold letters = Short-term availability

¹⁾ Only NG06.

²⁾ Only NG10.

Technical Data

General			
Design	Direct operated pressure relief valve, spool type		
Nominal size	NG06 (CETOP 03 / NFPA D03)	NG10 (CETOP 05 / NFPA D05)	
Interface	Subplate mounting according to ISO 5781		
Mounting position	unrestricted		
Ambient temperature	[°C]	-20...+60	
MTTF _D value	[years]	150	
Weight	[kg]	1.3	3.7
Hydraulic			
Max. operating pressure	[bar]	Port P and A 350 Port T depressurized	Port A and B 350 Port Y depressurized
Pressure stages	[bar]	25, 64, 160, 210, 350	64, 125, 210
Nominal flow	[l/min]	25	60
Fluid	Hydraulic oil according to DIN 51524		
Fluid temperature	[°C]	-20...+70	
Viscosity permitted	[cSt] / [mm ² /s]	20...400	
recommended	[cSt] / [mm ² /s]	30...80	
Filtration	ISO 4406 (1999); 18/16/13		

4

Characteristic Curves

p/Q performance curves

VB*06

Setting pressure max. 25 bar

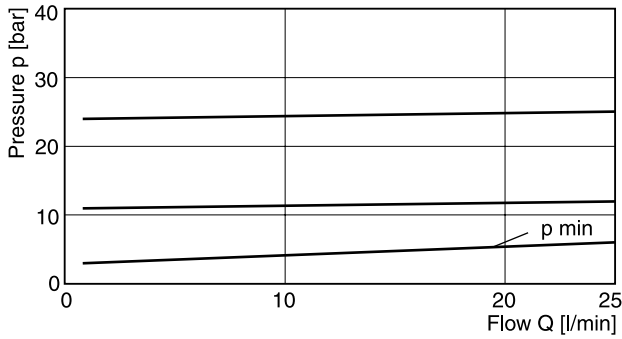

Setting pressure max. 64 bar

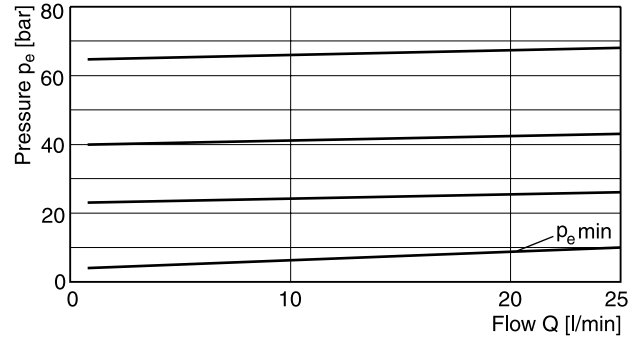

Setting pressure max. 160 or 210 bar

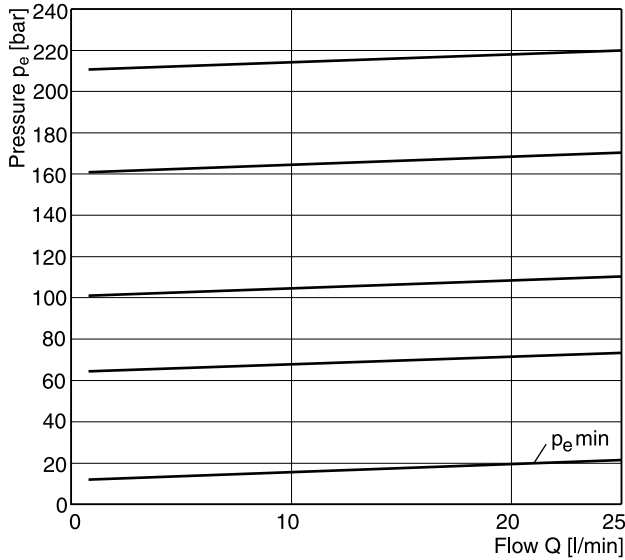

VB*10

Setting pressure max. 64 bar

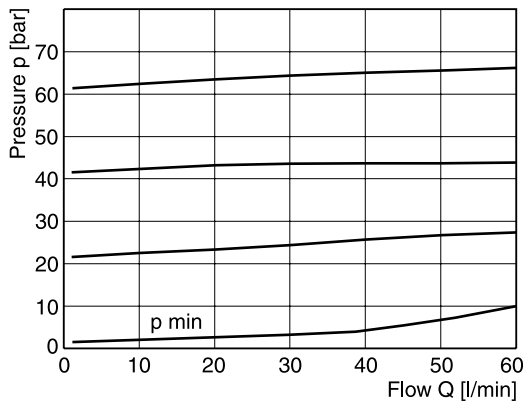

Setting pressure max. 210 bar

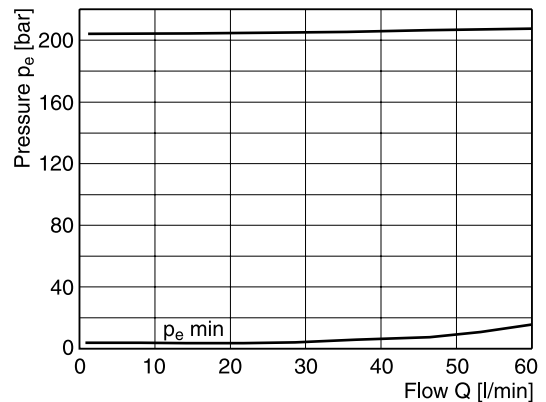

All characteristic curves measured with HLP46 at 50 °C.



VB UK.indd RH 17.04.2015

4

Dimensions

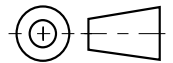
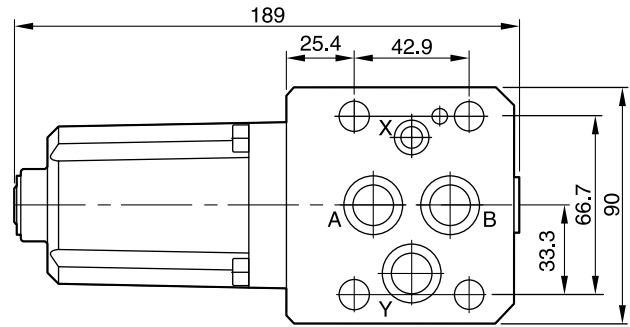
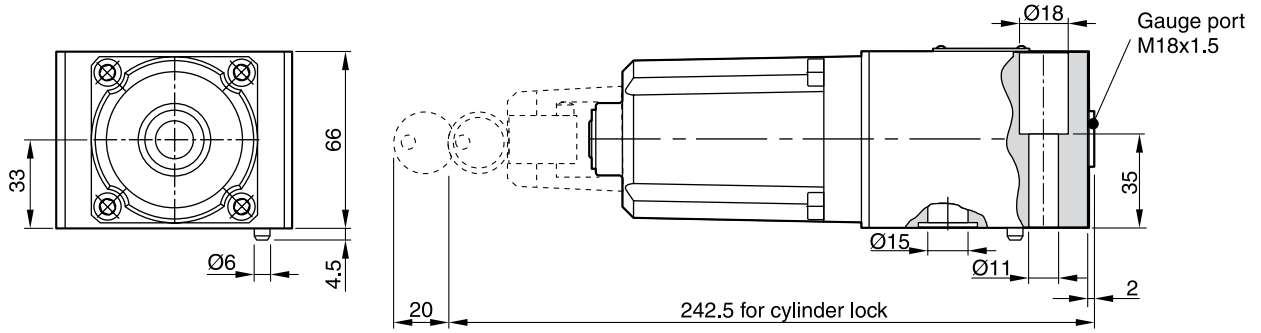
NG10

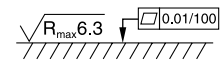

Surface finish	Bolt kit			 Kit FPM
	BK389	4x M10x50 ISO 4762-12.9	63 Nm ±15 %	SK-VB/VM-A10V

Mounting pattern ISO 5781-06-07-0-00 ¹⁾

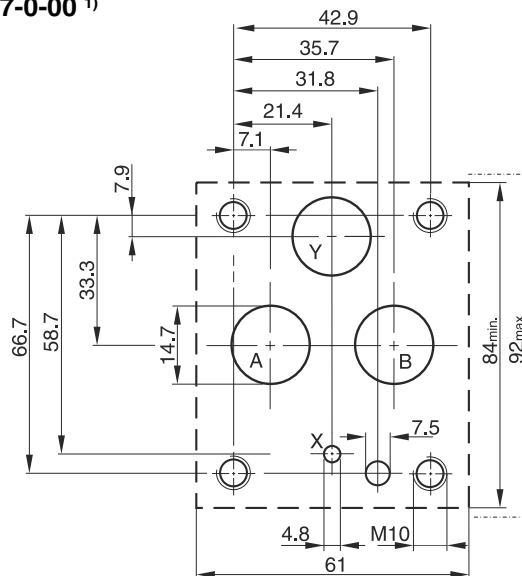

¹⁾ Deviating from ISO the Y port has Ø 14.7 instead of Ø 4.8.