

# OPEN CENTER VALVE ASSEMBLIES

## Models V20P, V20T, V20PT and V20S

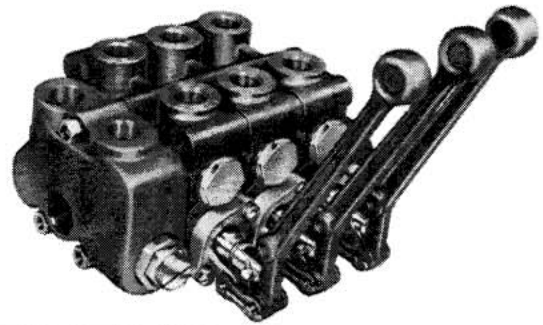

Models V20P, V20T, and V20S Valve Assemblies utilize the same inlet and outlet covers, and most of the same basic options.

Model V20P, V20T, and V20S sections may be combined into one valve assembly. See page 38 for V20S stacking sequence restrictions.

## FEATURES

- Minimal spool actuating effort—Maximum, 50 pounds [22,6 kg] at the spool
- Improved, extra-fine metering
- Minimum pressure drops through open center and through work ports
- Float section may be installed at any point within the Valve assembly

## INLET COVERS

All Model V20 valve inlet covers are machined for the Model WH main relief. If the relief is not required, a no relief (NR) plug will be installed. The following inlet covers are available:

### Inlet Cover, No. 8398

No. 8398 inlet cover is available with top, end and bottom inlet ports. It is also available with top and end outlet ports. Top in and top out are the standard port locations for this cover.

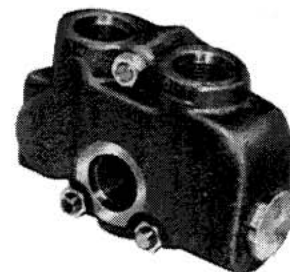

NO. 8398 INLET COVER

## SPECIFICATIONS

### Pressure Rating:

Continuous Operating ..... 3500 PSI [242 bar] max.

### Maximum Exhaust Core Pressure:

With Handle Bracket or Heavy Duty Spool Seal Retainer Installed

Continuous Operating ..... 500 PSI [ 34,5 bar]

Intermittent Peak ..... 1000 PSI [ 69,0 bar]

With Standard Spool Seal Retainer

Installed ..... 200 PSI [13,8 bar]

### Capacity ..... Refer to Pressure Drop Charts.

Flow rate is determined by the maximum pressure drop acceptable for the application.

Filtration Required (Min.) ..... 33 micrometre

### Weight:

Inlet Cover ..... Approx. 6 lbs. [2,7 kg]

Outlet Cover ..... Approx. 3 1/2 lbs. [1,6 kg]

Work Section, Each ..... Approx. 9 lbs. [4,1 kg]

## PORTING OPTIONS AVAILABLE

LOCATION	SAE STRAIGHT THREAD PORTS		NPT PIPE PORTS**	BSP PIPE PORTS	GAGE PORTS
	STANDARD	OPTIONAL	OPTIONAL	OPTIONAL	OPTIONAL
No. 8398 LEFT INLET COVER End, Top or Bottom* Inlet Ports. End or Top Outlet Ports.	SAE 12 (1-1/16" - 12 UN)	SAE 10 (7/8" - 14 UNF)	1/2" - 14 3/4" - 14	3/4" BSP	SAE 4 (7/16" - 14 UNF)

\*Bottom inlet available only with SAE 10 or 3/4" NPT ports.

\*\*NPT pipe ports are not recommended for pressure ports above 2000 PSI [138 bar].

NOTE: All ports in a casting must be the same type. SAE, BSP and NPT cannot be intermixed. Top inlet and top outlet ports are cored. If not specified, they will be plugged.

## Inlet Cover, No. 7736 With Flow Control

A No. 7736 Inlet Cover contains an adjustable flow control assembly which directs the controlled portion of the inlet flow to the work ports and any excess flow into the exhaust core. The adjusted flow is pressure compensated and is the maximum amount of flow available to any work section in the valve assembly.

This inlet cover is machined for the Model WH relief. A no relief (NR) plug may be installed if the main relief valve is not required.

### PORTING OPTIONS AVAILABLE

SAE and NPT ports cannot be intermixed in the same casting.

LOCATION	NPT PIPE PORTS		SAE STRAIGHT THREAD PORTS	
	STANDARD	OPTIONAL	STANDARD	OPTIONAL
END INLET	3/4"-14		SAE 12	SAE 10
TOP INLET	3/4"-14		SAE 12	SAE 10
END OUTLET	3/4"-14		SAE 12	

### FLOW CONTROL RANGE TO 25 GPM [95 litres/min].

A control knob is furnished as standard. If it is to be omitted, please specify.

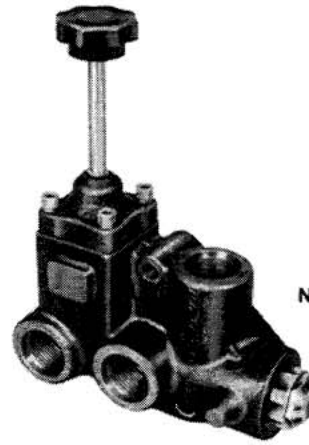

NO. 7736 INLET COVER

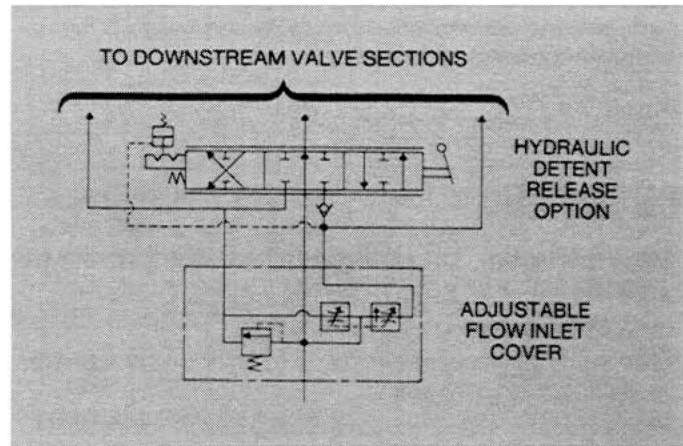

## Excess Flow Option

This option utilizes the excess flow from the flow control by using the end outlet port as the excess flow port. An outlet port is not available in this cover when this option is specified. A typical application for this option is to direct the excess flow to a combined flow mid-inlet section installed downstream. When the upstream spools are in neutral, all flow is avail-

able downstream. When an upstream spool is activated, only excess flow oil is available to the downstream spools. This option also allows the flow from one pump to be split for two separate functions.

To order this option, specify "Plug B end exhaust core".

## Main System Relief Valve

The main system relief valve is installed in the inlet cover. A detailed description of the main relief valve, its options and performance will be found on pages 10 and 11.

Relief setting at "crack pressure" or at "full flow" must be specified.

A main relief valve is available in the following configurations:

	ORDER CODE
Standard (adjustable with shims) . . . . .	WH
Tamperproof (adjustable with shims) . . . . .	WHNJ
Adjustable with screwdriver . . . . .	WHA
Pilot operated relief . . . . .	RP51
No Relief Plug (no relief valve installed). . . . .	NR

### OPTIONS:

- Stainless steel relief springs
- VITON seals to replace standard BUNA-N seals

# OUTLET COVERS

A variety of options and combinations of port sizes are offered. These options enable the user to customize valve assemblies while minimizing external plumbing. In addition, four application variations are available:

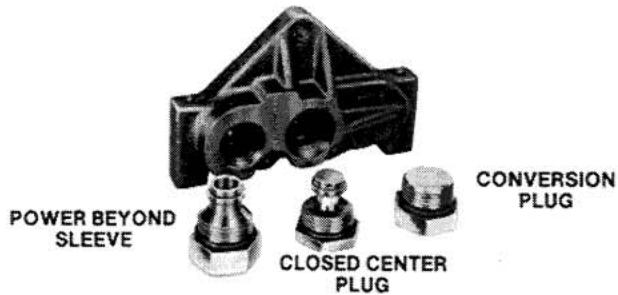

NO. 6770 OUTLET COVER WITH POWER BEYOND SLEEVE, CLOSED CENTER AND CONVERSION PLUG.

Outlet cover, No. 6770, is available for use with four application variations:

1. Open Center (standard)
2. Closed Center (conversion)
3. Power Beyond
4. Conversion Plug

Application variations are all accomplished by the machining and/or assembly of the outlet cover. Machining and assembly of the inlet cover and center sections do not affect these variations.

## Outlet Port Option ...

If the outlet port is to be located in the outlet cover and closed center, power beyond or conversion plug options are specified, then the outlet port will be in the optional location.

## Turnaround Cover Option ...

For plumbing convenience, the outlet port may be located in the inlet (left) cover. When it is, the turnaround (right) cover will direct the exhausting oil back to the inlet cover.

# Application Variations ...

Application variations are all accomplished by the machining and/or assembly of the outlet cover. Machining and assembly of the inlet cover and center sections do not affect these variations.

## OPEN CENTER

(Furnished as standard, unless otherwise specified)

Hydraulic oil is directed from the inlet port, thru the open center core to the outlet port of the Directional Control Valve when all spools are in the neutral position. Shifting the valve spool directs oil flow to the desired work port.

Maximum circuit pressure is limited by the main relief valve, which relieves into the exhaust core.

The standard Gresen valve is an open center control valve. The inlet port is open to the tank port, and both work ports are blocked when the control valve spool is in neutral position, thereby holding the cylinder or hydraulic motor in position.

The outlet port may be located in the right cover . . .

OR

Outlet port may be located in the left cover when a right turnaround cover is used.

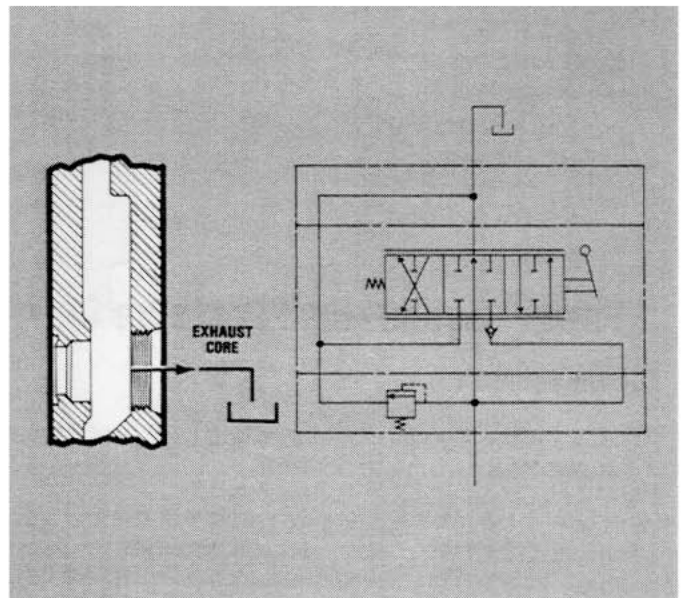

## Closed Center

### Code Symbol C

#### To convert an open center valve to a closed center valve.

By installing a special closed center plug in the outlet cover, hydraulic oil flow from the pump is blocked at the outlet port with valve spools in neutral position.

Pressure is normally maintained at the control valve inlet by use of a variable-displacement pump or an accumulator-type circuit with an unloading valve.

In a Gresen closed center control valve, the center passage is blocked and both work ports are also blocked when the control valve spool is in neutral position.

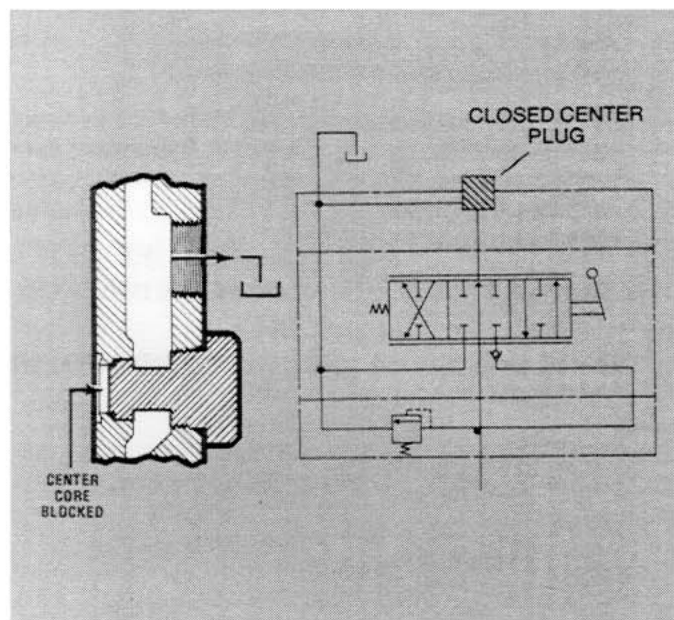

same, only one relief valve is required. It must be installed in the upstream valve.

Each valve in the circuit may have a different relief setting, but the highest setting must be upstream.

The outlet cover can be machined to accept a power beyond sleeve which allows the open center oil to be used by a downstream valve. When a power beyond sleeve is specified, an outlet port is still required. Outlet port can be located in the left inlet cover or in the right outlet cover. The following power beyond sleeve port sizes are available for No. 6770 right outlet cover:

THREAD	1/2" - 14 NPT (Female) SAE 8 (3/4" - 16 UN) (Female) SAE 10 (7/8" - 14 UN) (Female) SAE 16 (1" tube fitting) (Male)

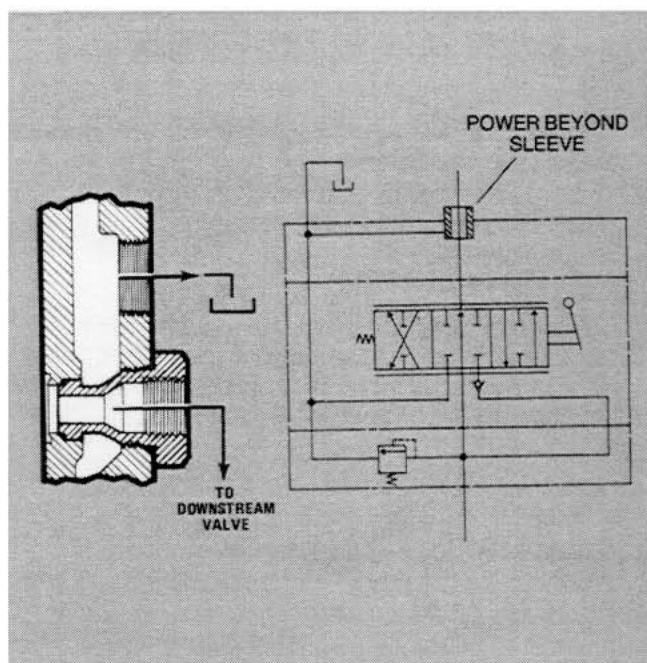

## Power Beyond (High Pressure Carryover)

### Code Symbol Y

This option allows the installation of another valve downstream from the first valve.

A power beyond sleeve is installed in the outlet cover of the upstream valve which separates the open center core from the exhaust core at the outlet port. This allows hydraulic oil under pressure to be carried thru the upstream valve, thus making it available for a downstream function. A separate tank line is required from each control valve in the circuit.

Hydraulic oil is available to the downstream valve only when all spools in the upstream valve are in the neutral position.

If pressure requirements for both valves are the

## Conversion Plug Assembly

### Code Symbol X

If additional hydraulic circuit options are to be added at a later date, or if the control valve is being ordered for stock, a conversion plug assembly should be considered. A conversion plug assembly gives a control valve great versatility and easily converts for different applications, reducing inventory requirements.

A control valve with a conversion plug remains an open center valve. The outlet cover, when machined for this option, will also accept power beyond sleeves and closed center plugs. When the need arises the proper plug or sleeve is inserted to convert the assembly into either a closed center or power beyond

valve. Service kits are available for these optional parts and must be ordered separately.

When a conversion plug is installed in the outlet cover the control valve remains an open center valve. When the outlet cover is machined for a conversion plug, it will also accept a power beyond sleeve or a closed center plug. If the need arises, the proper plug or sleeve can be inserted to convert the assembly to either a closed center or power beyond application.

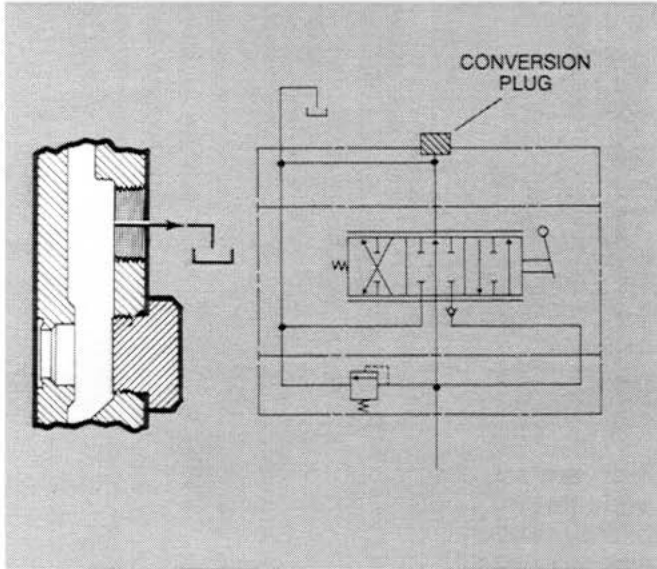

### Outlet Port Option

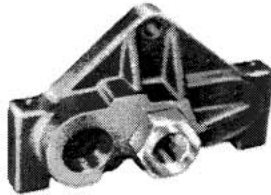

OUTLET COVER FOR MODEL V20P VALVE SHOWING OPTIONAL PORT LOCATION AND POWER BEYOND SLEEVE INSTALLED

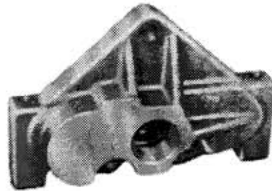

OUTLET COVER FOR MODEL V20P VALVE SHOWING STANDARD PORT LOCATION

If the outlet port is to be located in the outlet (right) cover and closed center, power beyond or conversion plug options are specified, then the outlet port will be in the optional location.

The following outlet port sizes are available for No. 6770 right outlet cover:

Outlet Ports	THREAD	
	NPT	SAE
	1/2" - 14	SAE 10 (7/8" - 14 UN)
	3/4" - 14	SAE 12 (1-1/16" - 12 UN)

### Turnaround Cover Option

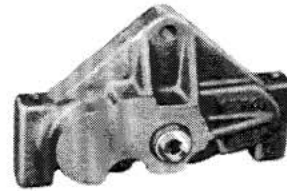

OUTLET COVER FOR MODEL V20P VALVE SHOWING TURNAROUND

For plumbing convenience, the outlet port may be located in the inlet (left) cover. When it is, the turnaround cover is provided to direct the flow of exhausting oil back to the inlet cover.

### Optional Outlet Cover with Top Outlet and Power Beyond Ports

No. 8644

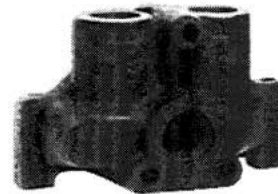

OPTIONAL OUTLET COVER FOR MODEL V20P VALVE SHOWING TOP OUTLET AND POWER BEYOND PORTS.

An optional outlet cover, No. 8644, is available. This option offers top porting options rather than end porting only. Port options are:

- Top, End or Bottom Outlet
- Top Power Beyond
- SAE12 or 3/4" NPT Ports

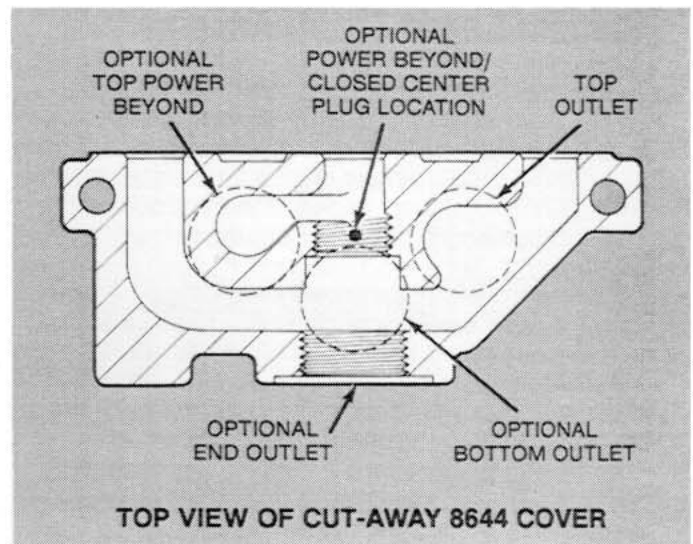

# WORK PORT RELIEFS, CHECKS AND RESTRICTORS

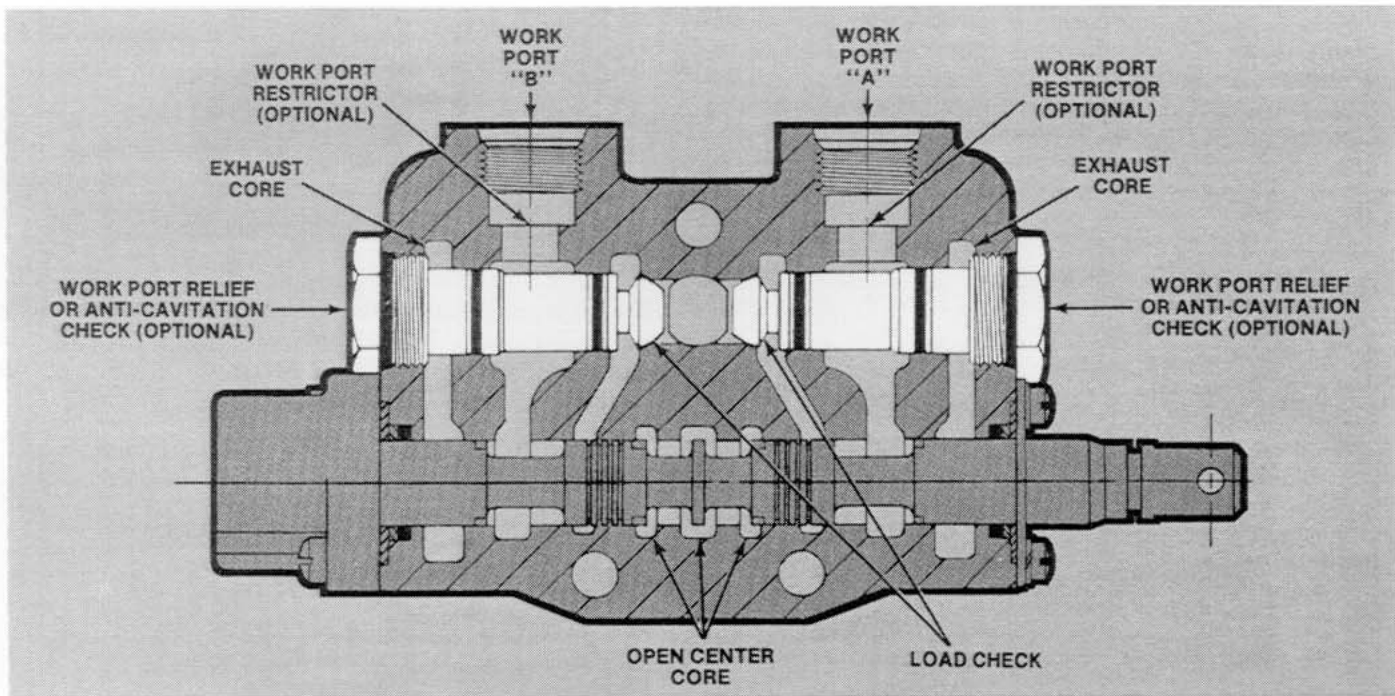

In addition to load checks which are standard in the V20 Valves, Gresen offers a wide range of options to control oil flow. From these options you may select the exact accessories to customize your valves to your specific application.

The following are available:

- Work Port Relief Valve
- Anti-Cavitation Check
- Combination Relief and Anti-Cavitation Check
- Pilot-Operated Check Valves
- Work Port Restrictors  
(not available with NPT pipe ports).

## Standard Load Check Assembly

A standard load check assembly is provided with every work section except when a free-flow motor spool is installed. Then load checks are not required. The load check blocks against pressurized return flow from a work port back to the inlet port until overcome by pressure build-up from the pump.

This feature will keep a load from dropping while the control valve spool is being shifted and until the inlet pressure is equal to or slightly greater than the pressure developed by the load. At this time the load check will open and movement of the load can then be controlled by the control valve spool.

NOTE: Load checks for Series type sections are different from those used in Parallel and Tandem sections.

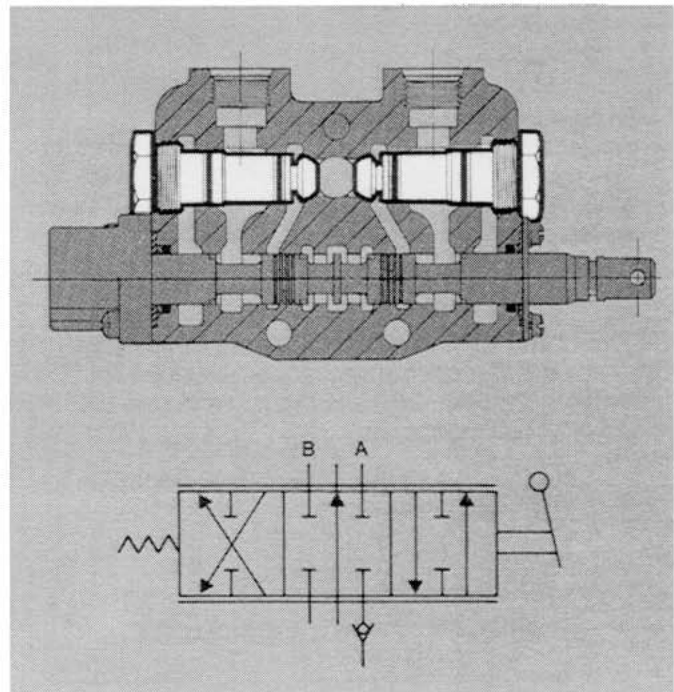

# Work Port Relief Valves

## MODELS RC and RCS (Series)

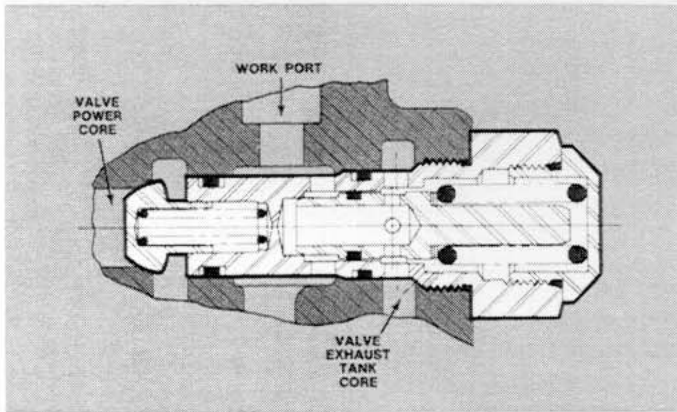

Models RC and RCS work port relief valves are differential poppet type.

Model RP20 recommended for pressures over 3000 PSI [207 bar].

NOTE: If the control valve is equipped with vertical handle, 1802-001, the adjustable relief valve, Model RCA which has an extended profile beyond valve body, will interfere with handle. It should NOT be installed on the valve-handle end.

These relief valves, installed in a work port, will limit the maximum pressure in that work port. They also prevent pressure build up in a work port when the valve spool is in neutral.

## MODEL RP20

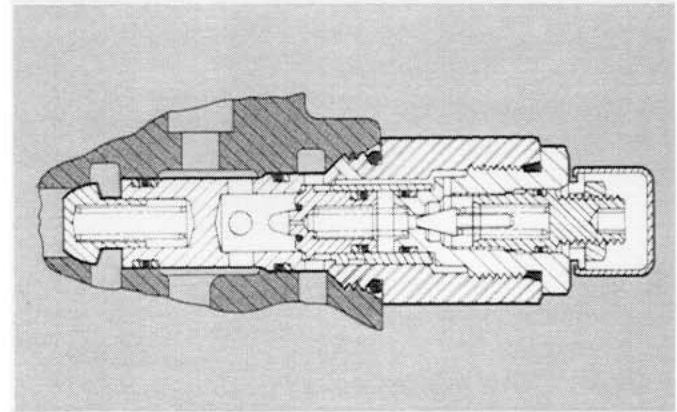

Model RP20 work port relief valves are pilot-operated type.

- Model RP20A — externally adjustable
- Model RP20N — tamperproof

## 2-STAGE RELIEF VALVE

A 2-stage relief option is available for Model RC work port relief valve cartridges. This option will provide a second (higher) pressure setting when a pilot pressure (750 PSI minimum) is applied to an SAE 6 pilot port in the cartridge. The "high" pressure setting (3000 PSI

maximum) is shim adjustable. The "low" pressure setting (500 PSI c/p minimum) is externally screw adjustable and must be specified as a "crack" pressure (1 GPM flow).

## Anti-Cavitation Check

The anti-cavitation check is used in the work section and prevents cylinder or motor cavitation. It allows cavitating work ports to refill from the exhaust core, supplementing pump flow. Anti-cavitation check is non-adjustable but is designed to operate whenever the work port pressure is lower than the exhaust core pressure.

NOTE: Anti-cavitation checks for Series type sections are different from those used in Parallel and Tandem sections.

### PERFORMANCE

- Will pass 5 GPM [18,93 liters/min] at 8 PSI [.55 bar] Pressure Differential
- Will pass 10 GPM [37,85 liters/min] at 19.5 PSI [1,35 bar] Pressure Differential
- Will pass 15 GPM [56,78 liters/min] at 39 PSI [2,69 bar] Pressure Differential

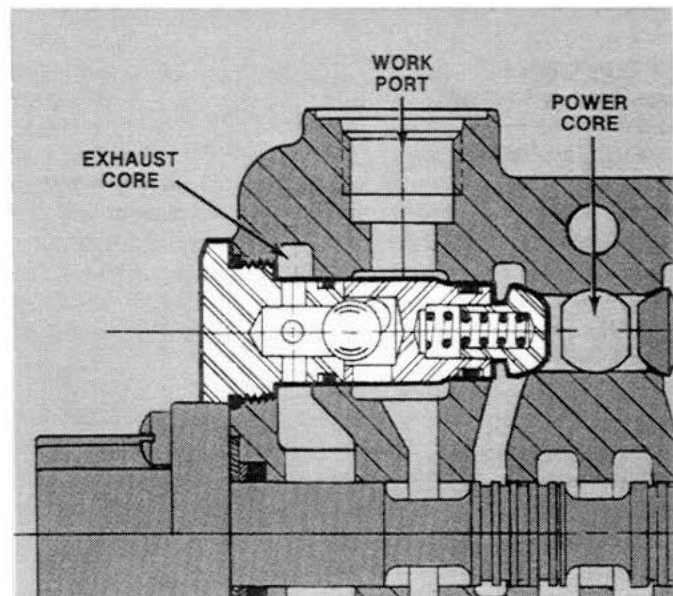

# Pilot-Operated Check Valves

FOR MODEL V20-LO VALVE ONLY

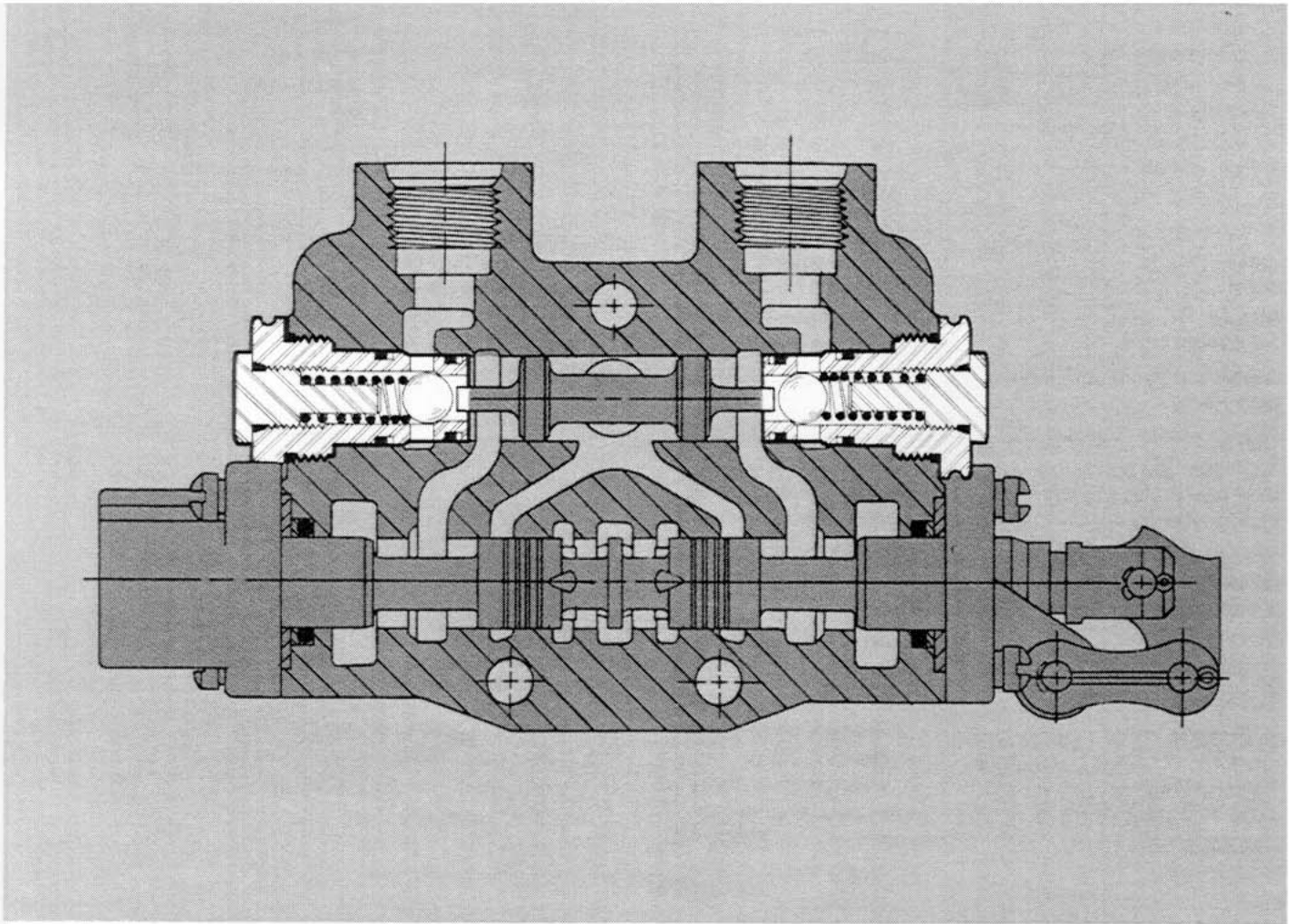

Model V20-LO work sections are designed with double pilot-operated check valves. These pilot operated checks will lock a cylinder or part of a circuit—without leakage—when the control valve spool is in the neutral position. When the spool is shifted to a power position, pressurized oil is directed to one work port. Return oil into the opposite work port is momentarily blocked until pilot pressure unseats the check. Metering characteristics of valve spools are slightly diminished when using these pilot-operated check valves.

These checks are used on applications such as clamps, outriggers, and elevated work platforms where internal fluid leakage could affect the operation of the system. The functions of a 4-Way Section and a pilot-operated check or lock-out in one valve housing are combined in one section.

The spool is a 4-way, 3-position modified free flow spool.

This spool is the same as F4, 4-way, 3-position free flow except the free flow feature is restricted. Free flow prevents any pressure build up between the pump and the pilot operated check when the valve spool is in neutral position.

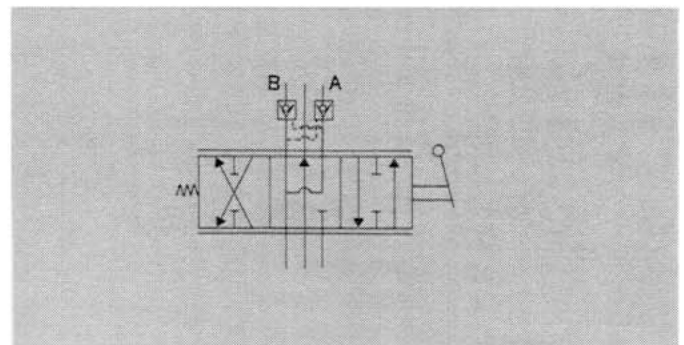

This work section and check valve are combined to perform the functions of a 4-way work section and a pilot-operated check or lockout valve in one single housing.



# Combination Work Port Relief Valve and Anti-Cavitation Check

## MODEL CRA

At times both a relief valve and an anti-cavitation check are required for the same work port. Both of those functions have been incorporated into one assembly.

Pressure range is: 500-3000 PSI [34-207 bar]

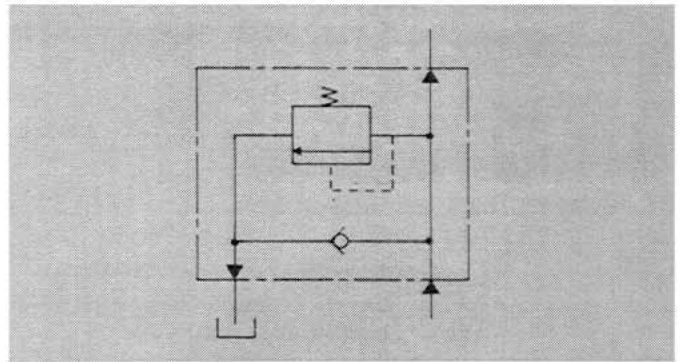
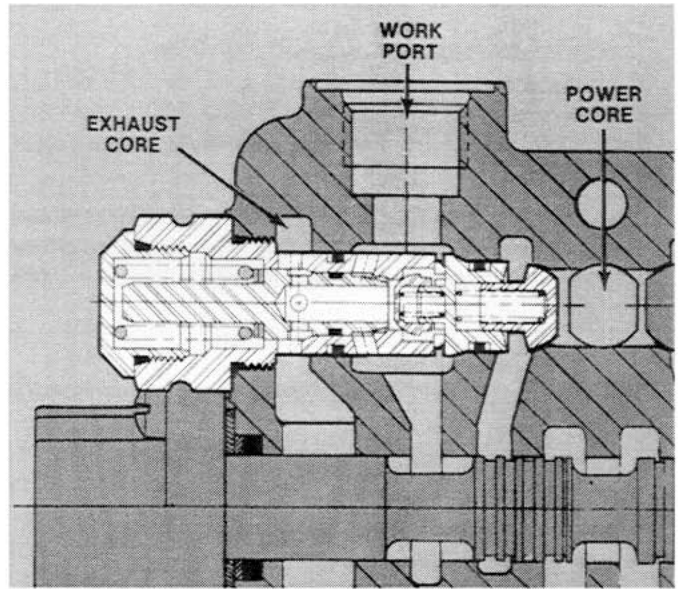

## Restrictors

Restrictors may be inserted directly into a SAE work port and will limit oil flow in one direction while allowing free flow in the opposite direction. When restricting flow in the return port, restrictors will:

1. Prevent cylinder or motor cavitation having an inertia load.
2. Provide accurate control of double-acting cylinder by pressurizing both sides of cylinder piston.
3. Restrict oil flow from a hydraulic motor for smoother operation.

When restricting flow in pressure port, restrictors will meter oil flow to provide proper speed of operation.

Work port restrictors are available for SAE 8 and SAE 10 work ports. Nominal orifice diameters are available from .015 to .220 inches [.38 to 5.6 mm]. Specify restrictor hole size desired. Specify whether restrictor should be installed to restrict flow out of the valve work port, or restrict flow into the valve work port.

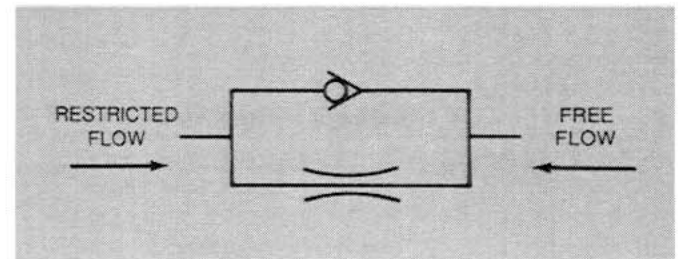
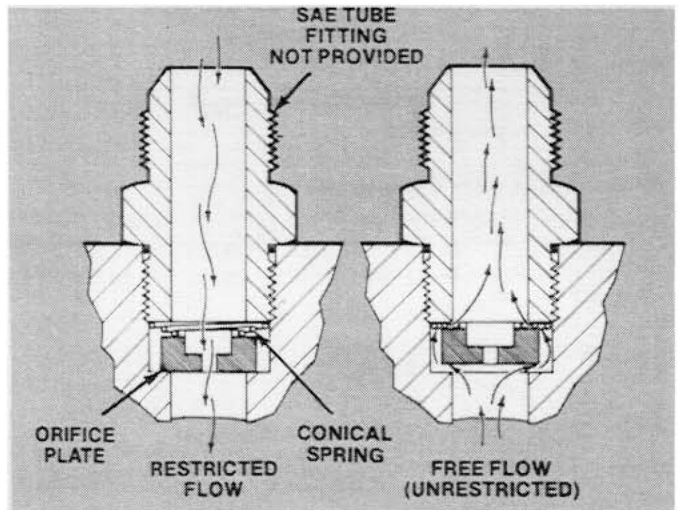

# MID-INLET CONVERSION SECTIONS

A mid-inlet conversion section provides an inlet port for a secondary pump downstream in the valve assembly. These sections can be installed between any two work sections thereby providing two different flow paths.

The addition of a mid-inlet section actually combines two separate valve assemblies into one giving them one common tank return line that provides the following advantages:

1. Simplifies installation, reducing plumbing and mounting costs.
2. All valve control handles can be mounted within easy reach.
3. Overall assembly costs are lower than two separate control valves.

Mid-inlet conversion sections are available in the following configurations:

1. Combined Flow Section
2. Split Flow Section
3. Combination 3-Way Work Section and Mid-Inlet Section

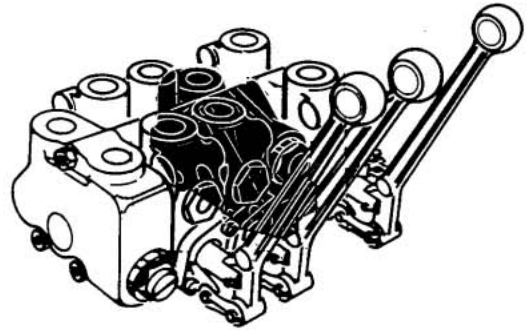

## Combined Flow Section

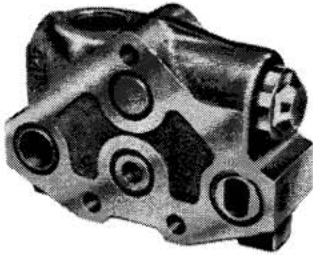

MID-INLET CONVERSION SECTION WITH COMBINED FLOW

When upstream work sections are in the neutral position, the combined flow from both pumps is available to the downstream sections. Combined flow of both pumps cannot exceed the flow capacity of the entire valve.

## Split Flow Section

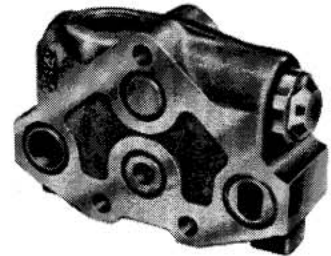

MID-INLET CONVERSION SECTION WITH SPLIT FLOW

Except for a common tank return passage, the split flow section completely separates upstream and downstream work sections. Upstream sections are fed by the primary pump, downstream work sections by the secondary pump.

When ordering a Combined Flow or Split Flow Mid-Inlet Conversion Section be sure to specify:

- Port Size
- Port Location
- Relief Valve Type
- Relief Valve Setting

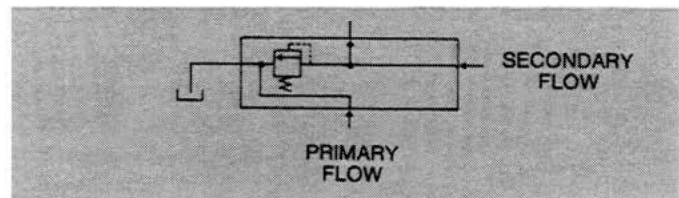
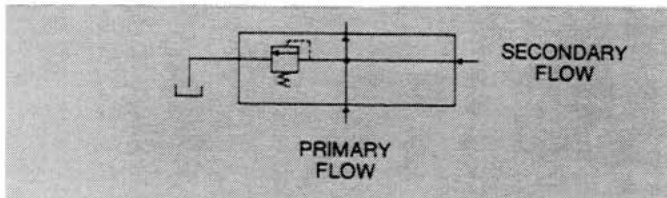

### PORTING OPTIONS AVAILABLE (Combined Flow and Split Flow Sections)

LOCATION	NPT PIPE PORTS		SAE STRAIGHT THREAD PORTS	
	STANDARD	OPTIONAL	STANDARD	OPTIONAL
TOP INLET	1/2"-14	3/4"-14	SAE 10 (7/8"- 14 UN)	SAE 12 (1-1/16"- 12 UN)
BACK INLET	1/2"-14	3/4"-14	SAE 10 (7/8"- 14 UN)	SAE 12 (1-1/16"- 12 UN)

## Combination 3-Way Work Section and Mid-Inlet Section

A special 3-way spool is used to convert a tandem work section to a combination 3-way work section and mid-inlet section. Port "A", which is normally plugged in a 3-way work section, is used as the mid-inlet port. A modified work port relief valve installed in port "A" serves as the main relief valve for the secondary pump.

This combination section eliminates the need for separate combined flow mid-inlet section, thus reducing the size and weight of the complete valve assembly. It can be used in any V20 open center application where a 3-way section requires a combined flow. Any number of 3-way or 4-way work sections which require a combined flow can be used downstream from this section.

To order, specify Bill of Material No. 1522-8137. Also, specify port size, relief pressure setting and whether clevis is to be located on the "A" or "B" port end.

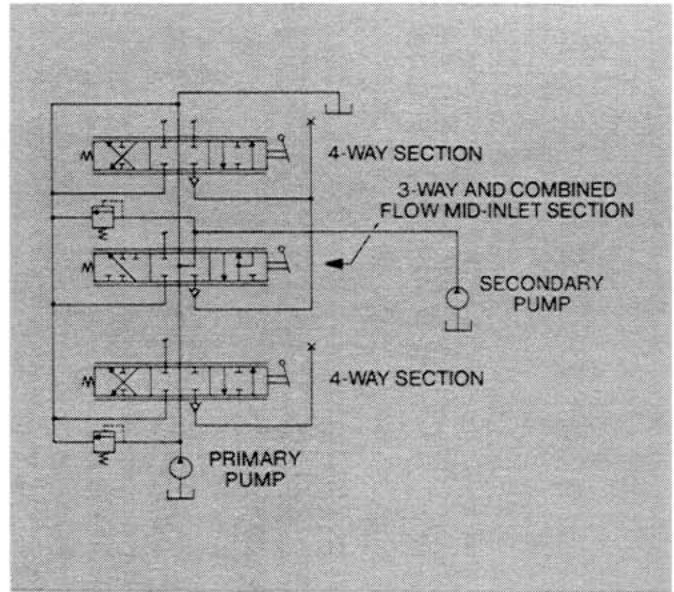

# ORDERING OPTIONS FOR MODEL V20P AND V20RP\* OPEN CENTER WORK SECTIONS

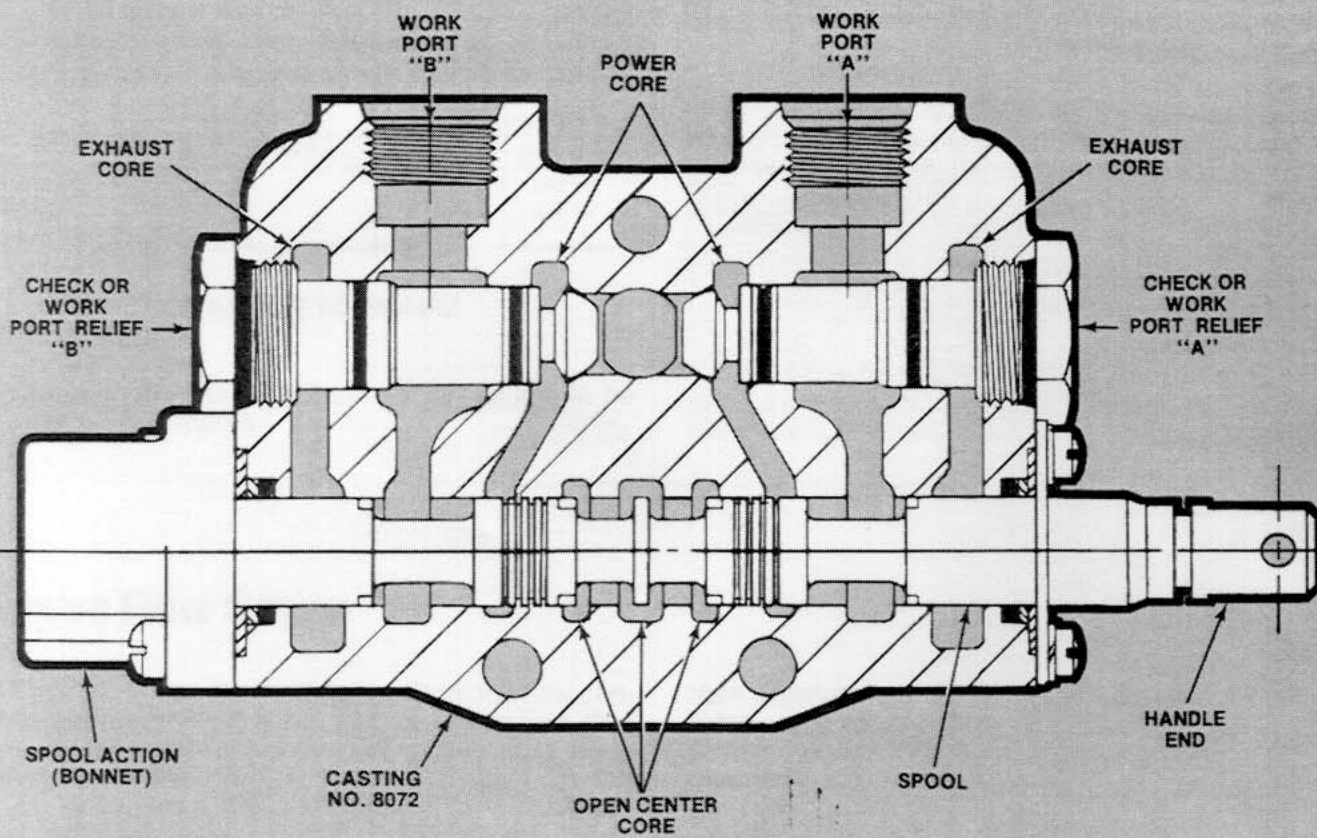

\*Reduced open center pressure drop

**SPOOL ACTION OPTIONS (BONNET)** (Refer to pages 14-19)

	ORDER CODE
Spring Return to Neutral	Furnished as Standard
3-Position Detent, No Spring Centering	D
Detent Stop for Neutral and Spool "IN" or Neutral and Spool "OUT" } Specify	1889 Stop
1-Position Spool "IN" Detent with Spring Return to Neutral	R
1-Position Spool "OUT" Detent with Spring Return to Neutral	RO
2-Position Spool "IN" and "OUT" Detent with Spring Return to Neutral	RIO
Hydraulic Detent Release from "A" or "B" Port	KO
Electro-Magnetic Detent Release	E
4-Way, 4-Position Float Spool	K4
Spring Extended Spool	A
Manual Spool, No Spring Centering or Detent	M
Solenoid Control (Request Catalog No. PC-1104)	—
Hydraulic Remote Actuator	HR, HRO, HRH

**SPOOL OPTIONS** (Refer to page 13)

Spool option must be specified.

	ORDER CODE
3-Way, 3-Position	3
4-Way, 3-Position	4
3-Way, 3-Position, Free Flow	F3
4-Way, 3-Position, Free Flow	F4
4-Way, 4-Position Float	K4

**HANDLE END OPTIONS** (Refer to pages 20-21)

Handle end may be located at either "A" or "B" port end. "A" port handle location is furnished as standard. Handles and brackets may be rotated 180° from standard. Handle options must be specified.

Standard Seal Retainer Assembly*	LCHA
Heavy Duty Seal Retainer Assembly	H.D. Retainer
Die Cast Handle Bracket, No. 1801-001	1801 Bracket
Cast Iron Handle Bracket, No. 7355-001	7355 Bracket
Vertical Handle, No. 1802-001 Black Plastic Coating**	CVHA
Horizontal Handle, No. 3249-001 Black Plastic Coating**	CHHA
Spool Wiper, No. 1800-001	1800 Wiper
Spool Boot Assembly	Spool Boots

\* Standard Seal Retainer Assembly is limited to 500 PSI [34.5 bar] in the exhaust core, all other options are limited to 1000 PSI [69.0 bar].

\*\*Handles are also available with plain cast iron. (See page 20.)

**MODEL V20-LO WORK SECTION OPTION WITH DOUBLE PILOT-OPERATED CHECK** (Refer to page 30)

Spool is a 4-way, 3-position with modified free flow.

Overall height of V20-LO casting is 3/32 inch more than standard V20 Casting No. 8072.

**Options Available:**

- Work port restrictors (SAE ports only)
- Expansion relief valves (refer to catalog No. PC-4000) for "A" or "B" ports (specify pressure setting)

**WORK PORT OPTIONS**

**SIZES:** All ports in the same work section must be the same size, they cannot be mixed. Port size must be specified.

THREAD
3/8" - 18 NPT
1/2" - 14 NPT
SAE 8 (3/4" - 16 UN)
SAE 10 (7/8" - 14 UN)
SAE 12 (1-1/16" - 12 UN) (V20RP only)
1/2" BSP

**WORK PORT RELIEF VALVES and ANTI-CAVITATION CHECKS**

(Refer to pages 29-31).

The following relief valves and anti-cavitation checks are installed in "A" and/or "B" work ports. When a 3-way spool is specified, work port nearest handle end is plugged.

	ORDER CODE
Load Check Assembly (Not provided with free flow spools)	Furnished as Standard
Work Port Relief, Differential Poppet	RC
Work Port Relief, Differential Poppet, Adj.	RCA
Work Port Relief, Pilot-Operated, Adjustable	RP20A
Work Port Relief, Pilot-Operated, Non-Adj.	RP20N
Anti-Cavitation Check	AC
Combination-Work Port Relief and Anti-Cavitation Check	CRA
Double Pilot-Operated Check Assembly	V20-LO

Specify relief valve settings required.

**Note:** If valve is equipped with vertical handle, 1802-001, work port relief valve, Model RCA, which has an extended profile beyond valve body, will interfere with handle. It should NOT be installed on the valve handle end.

**RESTRICTORS** (Refer to page 31).

Restrictors installed in "A" or "B" ports are available for the following port sizes:

THREAD
SAE 8 (3/4" - 16 UN)
SAE 10 (7/8" - 14 UN)

Specify restrictor hole size desired.

Specify whether restrictor should be installed to restrict flow out of the work port, or restrict flow into the work port.

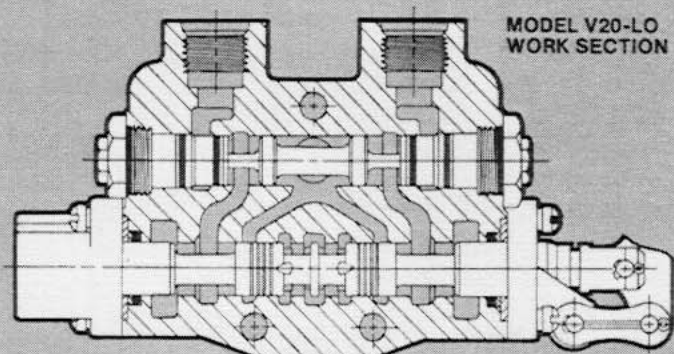

# ORDERING OPTIONS FOR MODEL V20T AND V20RT\* OPEN CENTER WORK SECTIONS

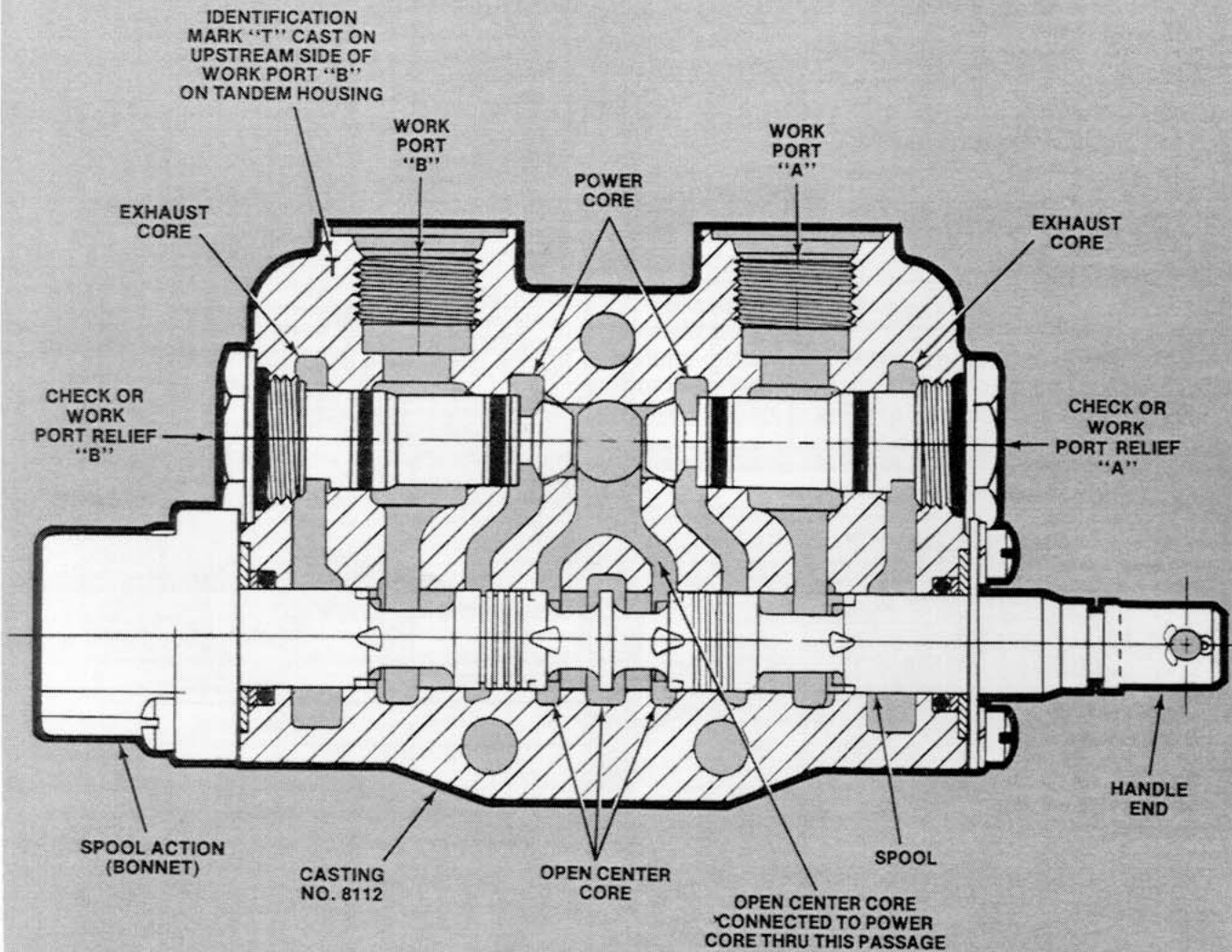

\*Reduced open center pressure drop

SPOOL ACTION OPTIONS (BONNET) (Refer to pages 14-19)	
	ORDER CODE
Spring Return to Neutral	Furnished as Standard
3-Position Detent, No Spring Centering	D
Detent Stop for Neutral and Spool "IN" or Neutral and Spool "OUT" Specify	1889 Stop
1-Position Spool "IN" Detent with Spring Return to Neutral	R
1-Position Spool "OUT" Detent with Spring Return to Neutral	RO
2-Position Spool "IN" and "OUT" Detent with Spring Return to Neutral	R/O
Hydraulic Detent Release from "A" or "B" Port	KO
Electro-Magnetic Detent Release	E
4-Way, 4-Position Float Spool	K4
Spring Extended Spool	A
Manual, Spool, No Spring Centering or Detent	M
Solenoid Control	—
Hydraulic Remote Actuator	HR, HRO, HRH

SPOOL OPTIONS (Refer to page 13) Spool option must be specified	
	ORDER CODE
3-Way, 3-Position	3
4-Way, 3-Position	4
3-Way, 3-Position Free Flow	F3
4-Way, 3-Position Free Flow	F4
4-Way, 4-Position Float	K4

HANDLE END OPTIONS (Refer to pages 20-21)	
Handle end may be located at either "A" or "B" port end. "A" port handle location is furnished as standard. Handles and brackets may be rotated 180° from standard. Handle options must be specified.	
Standard Seal Retainer Assembly*	LCHA
Heavy Duty Seal Retainer Assembly	H.D. Retainer
Die Cast Handle Bracket, No. 1801-001	1801 Bracket
Cast Iron Handle Bracket, No. 7355-001	7355 Bracket
Vertical Handle, No. 1802-001 Black Plastic Coating**	CVHA
Horizontal Handle, No. 3249-001 Black Plastic Coating**	CHHA
Spool Wiper, No. 1800-001	1800 Wiper
Spool Boot Assembly	Spool Boots

\* Standard Seal Retainer Assembly is limited to 500 PSI [34,5 bar] in the exhaust core, all other options are limited to 1000 PSI [69,0 bar].

\*\*Handles are also available with plain cast iron. (See page 20.)

WORK PORT OPTIONS
<b>SIZES:</b> All ports in the same work section must be the same size, they cannot be mixed. Port size must be specified.
THREAD
3/8" - 18 NPT 1/2" - 14 NPT SAE 8 (3/4" - 16 UN) SAE 10 (7/8" - 14 UN) SAE 12 (1-1/16" - 12 UN) (V20 RT only) 1/2" BSP

WORK PORT RELIEF VALVES and ANTI-CAVITATION CHECKS (Refer to pages 29-31).	
The following relief valves and anti-cavitation checks are installed in "A" and/or "B" work ports. When a 3-way spool is specified, work port nearest handle end is plugged.	
	ORDER CODE
Load Check Assembly (Not provided with free flow spools)	Furnished as Standard
Work Port Relief, Differential Poppet	RC
Work Port Relief, Differential Poppet, Adj.	RCA
Work Port Relief, Pilot-Operated, Adjustable	RP20A
Work Port Relief, Pilot-Operated, Non-Adj.	RP20N
Anti-Cavitation Check	AC
Combination-Work Port Relief and Anti-Cavitation Check	CRA

Specify relief valve settings required.

**Note:** If valve is equipped with vertical handle, 1802-001, work port relief valve, Model RCA, which has an extended profile beyond valve body, will interfere with handle. It should NOT be installed on the valve handle end.

RESTRICTORS (Refer to page 31)
Restrictors installed in "A" or "B" ports are available for the following port sizes:
THREAD
SAE 8 (3/4" - 16 UN) SAE 10 (7/8" - 14 UN)

Specify restrictor hole size desired.

Specify whether restrictor should be installed to restrict flow out of the work port, or restrict flow into the work port.

# ORDERING OPTIONS FOR MODEL V20S OPEN CENTER WORK SECTIONS

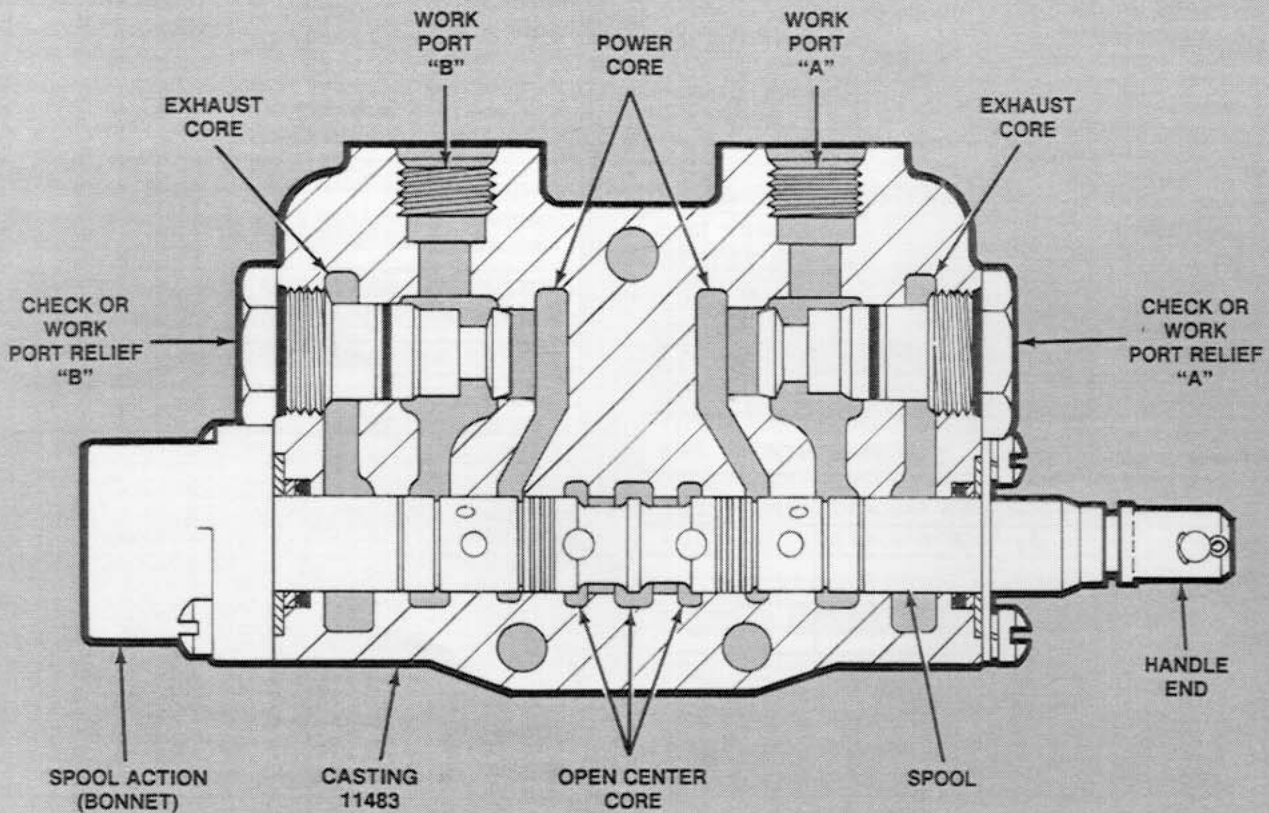

## STACKING SEQUENCE RESTRICTIONS

Model V20S series sections may be stacked in a V20P parallel valve assembly allowing series and parallel circuits in the same control valve.

When mixing series and parallel sections in the same stack, a tandem section is always required between the series and parallel sections if the series sections are upstream. If the parallel sections are upstream, then the series sections may

be stacked directly downstream of a parallel section.

When assembling or specifying V20S series sections in a stack, it is not necessary to have a V20S section as the last section in the stack unless series flow is required through a power beyond sleeve to a downstream valve.



SPOOL ACTION OPTIONS (BONNET) (Refer to pages 14-19)	
	ORDER CODE
Spring Return to Neutral	Furnished as Standard
3-Position Detent, No Spring Centering	D
Detent Stop for Neutral and Spool "IN" or Neutral and Spool "OUT" Specify	1889 Stop
1-Position Spool "IN" Detent with Spring Return to Neutral	R
1-Position Spool "OUT" Detent with Spring Return to Neutral	RO
2-Position Spool "IN" and "OUT" Detent with Spring Return to Neutral	RIO
Hydraulic Detent Release from "A" or "B" Port	KO
Electro-Magnetic Detent Release	E
4-Way, 4-Position Float Spool	K4
Spring Extended Spool	A
Manual, Spool, No Spring Centering or Detent	M
Solenoid Control	—
Hydraulic Remote Actuator	HR, HRO, HRH

SPOOL OPTIONS (Refer to page 13) Spool option must be specified	
	ORDER CODE
3-Way, 3-Position	3
4-Way, 3-Position	4
3-Way, 3-Position Free Flow	F3
4-Way, 3-Position Free Flow	F4
4-Way, 4-Position Float	K4

HANDLE END OPTIONS (Refer to pages 20-21)	
Handle end may be located at either "A" or "B" port end. "A" port handle location is furnished as standard. Handles and brackets may be rotated 180° from standard. Handle options must be specified.	
Standard Seal Retainer Assembly*	LCHA
Heavy Duty Seal Retainer Assembly	H.D. Retainer
Die Cast Handle Bracket, No. 1801-001	1801 Bracket
Cast Iron Handle Bracket, No. 7355-001	7355 Bracket
Vertical Handle, No. 1802-001 Black Plastic Coating**	CVHA
Horizontal Handle, No. 3249-001 Black Plastic Coating**	CHHA
Spool Wiper, No. 1800-001	1800 Wiper
Spool Boot Assembly	Spool Boots

\*Standard Seal Retainer Assembly is limited to 500 PSI [34.5 bar] in the exhaust core, all other options are limited to 1000 PSI [69.0 bar].

\*\*Handles are also available with plain cast iron. (See page 20.)

WORK PORT OPTIONS
<b>SIZES:</b> All ports in the same work section must be the same size, they cannot be mixed. Port size must be specified.
THREAD
3/8" - 18 NPT 1/2" - 14 NPT SAE 8 (3/4" - 16 UN) SAE 10 (7/8" - 14 UN) 1/2" BSP

WORK PORT RELIEF VALVES and ANTI-CAVITATION CHECKS (Refer to pages 29-31)	
The following relief valves and anti-cavitation checks are installed in "A" and/or "B" work ports. When a 3-way spool is specified, work port nearest handle end is plugged.	
	ORDER CODE
Load Check Assembly (Not provided with free flow spools)	Furnished as Standard
Work Port Relief, Differential Poppet	RC
Work Port Relief, Differential Poppet, Adj.	RCA
Work Port Relief, Pilot-Operated, Adjustable	RP20A
Work Port Relief, Pilot-Operated, Non-Adj.	RP20N
Anti-Cavitation Check	AC
Combination Work Port Relief and Anti-Cavitation Check	CRA

Specify relief valve settings required.

**Note:** If valve is equipped with vertical handle, 1802-001, work port relief valve, Model RCA, which has an extended profile beyond valve body, will interfere with handle. It should NOT be installed on the valve handle end.

RESTRICTORS (Refer to page 31)
Restrictors installed in "A" or "B" ports are available for the following port sizes:
THREAD
SAE 8 (3/4" - 16 UN) SAE 10 (7/8" - 14 UN)

Specify restrictor hole size desired.

Specify whether restrictor should be installed to restrict flow out of the work port, or restrict flow into the work port.

# V20P, V20T or V20PT OPEN CENTER PRESSURE DROP

Left End In  
To Left End Out

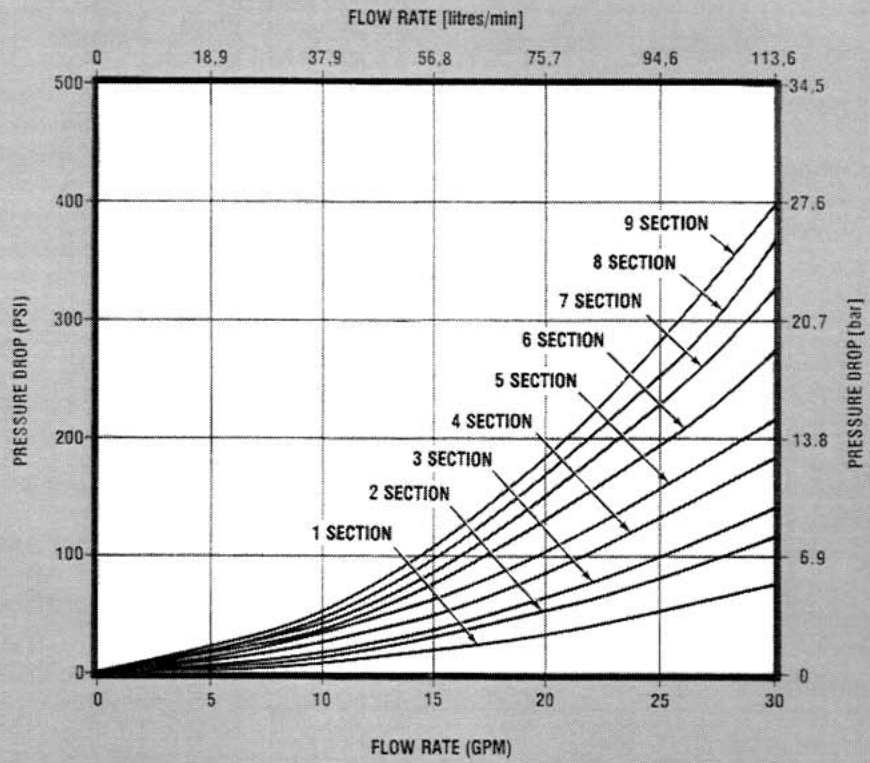

Left End In  
To Right End Out

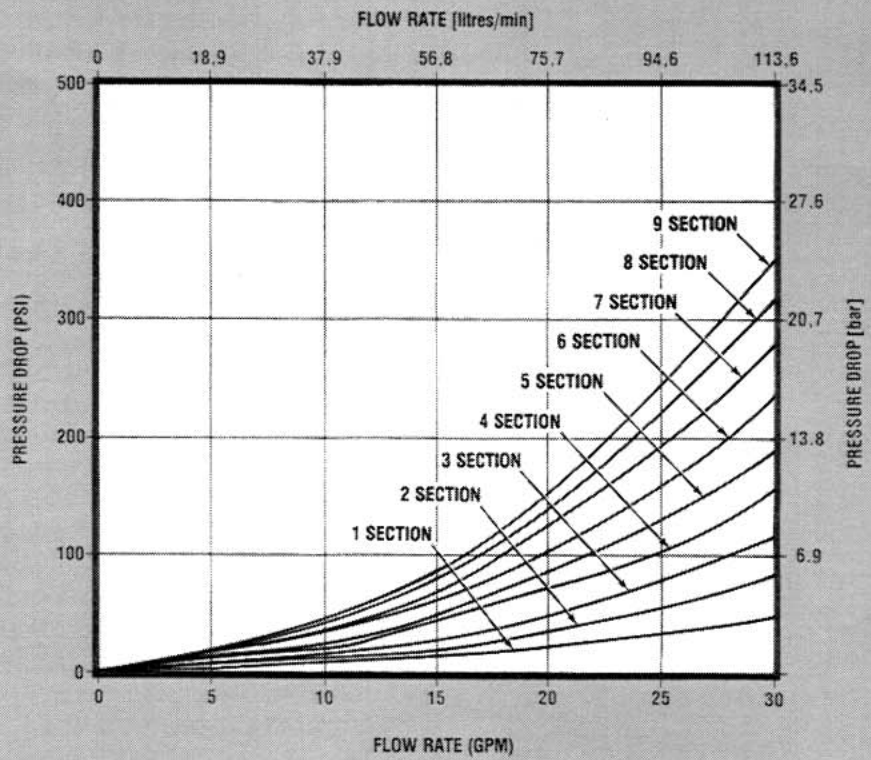

Curves derived from actual laboratory tests run with 150 SUS oil, at 100°F [38°C].  
SAE 12 inlet and outlet ports, and SAE 10 work ports.

# V20P, V20T or V20PT INTERNAL PRESSURE DROP

Left End In To  
Work Ports "A" or "B"

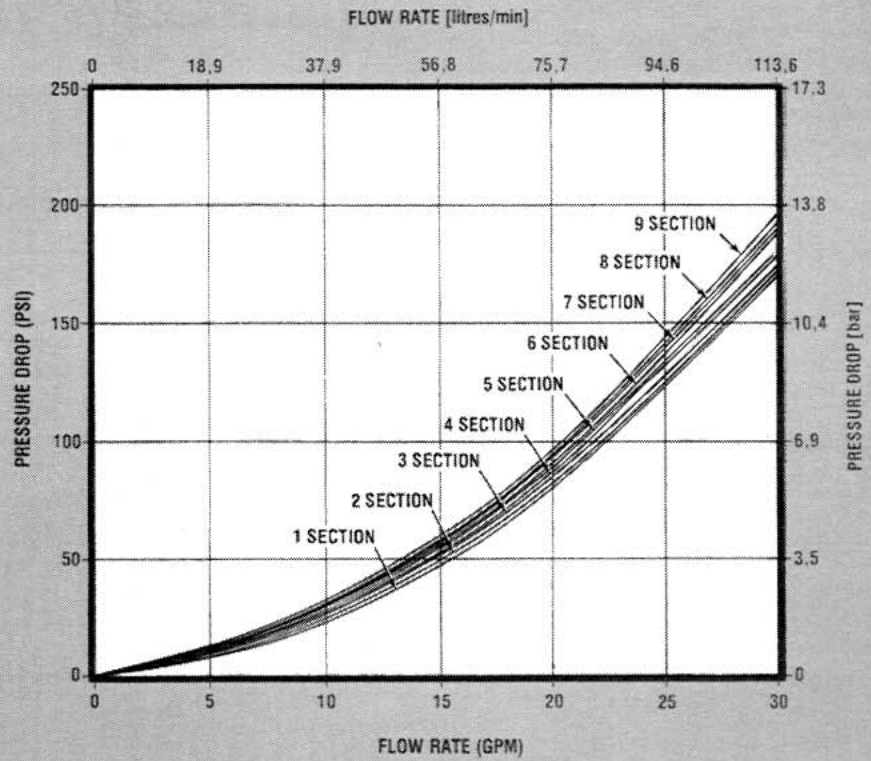

Curves derived from actual laboratory tests run with 150 SUS oil, at 100°F [38°C].  
SAE 12 inlet and outlet ports, and SAE 10 work ports.

# V20P, V20T or V20PT INTERNAL PRESSURE DROP

Work Port "A"  
To Right End Outlet

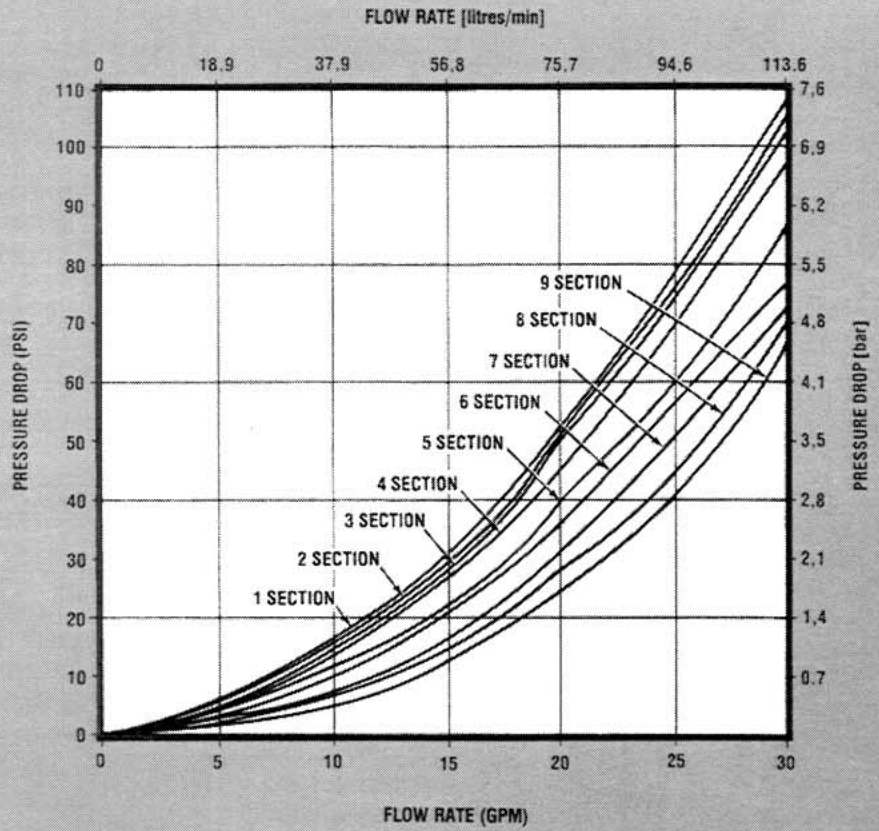

Work Port "B"  
To Right End Outlet

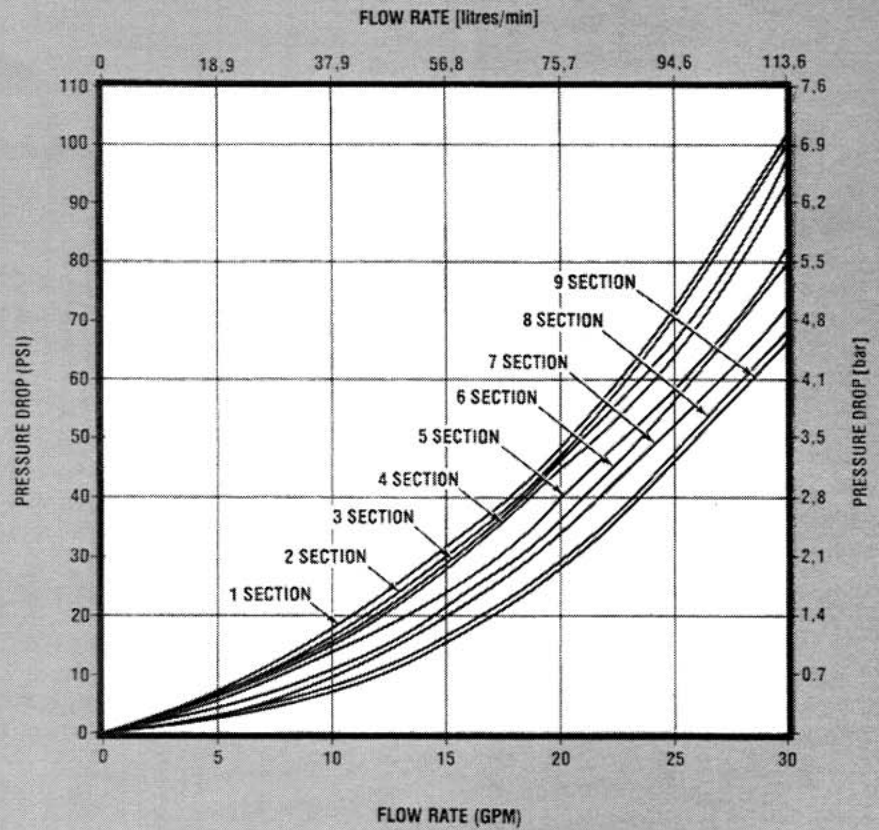

Curves derived from actual laboratory tests run with 150 SUS oil, at 100°F [38°C].  
SAE 12 inlet and outlet ports, and SAE 10 work ports.

# V20P, V20T or V20PT INTERNAL PRESSURE DROP

Work Port "A"  
To Left End Outlet

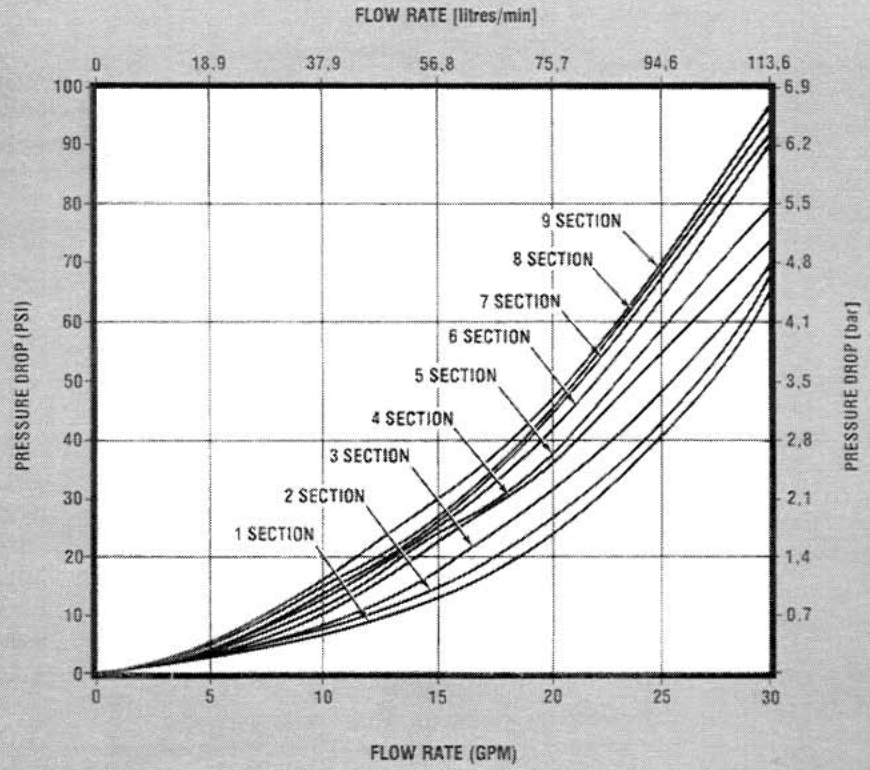

Work Port "B"  
To Left End Outlet

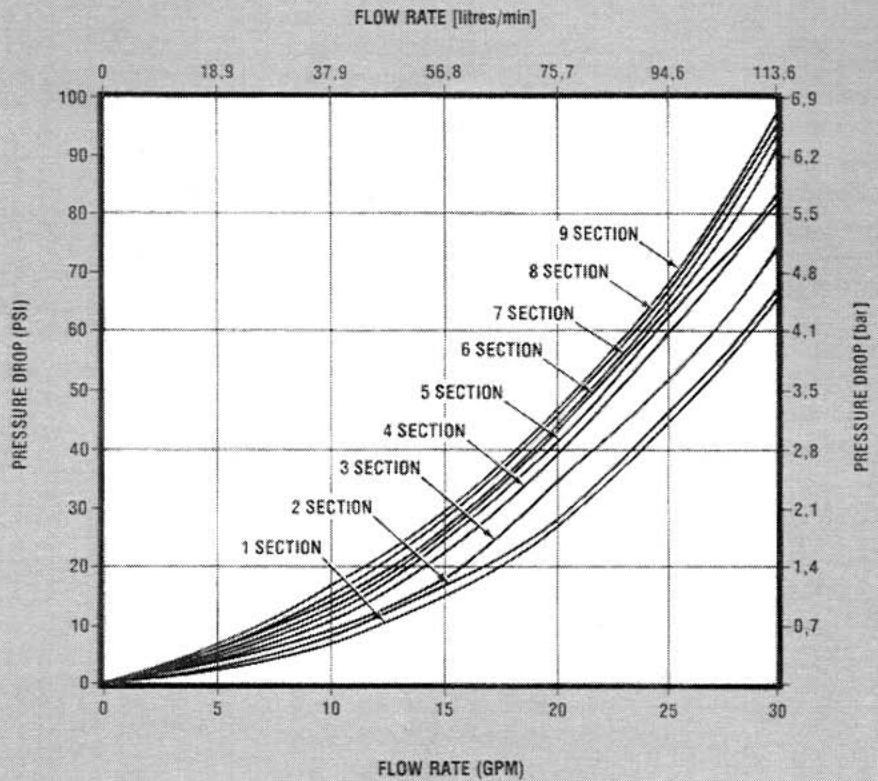

Curves derived from actual laboratory tests run with 150 SUS oil, at 100°F [38°C].  
SAE 12 inlet and outlet ports, and SAE 10 work ports.

# V20S (SERIES) OPEN CENTER PRESSURE DROP

Left Top Inlet  
To Left Top Outlet

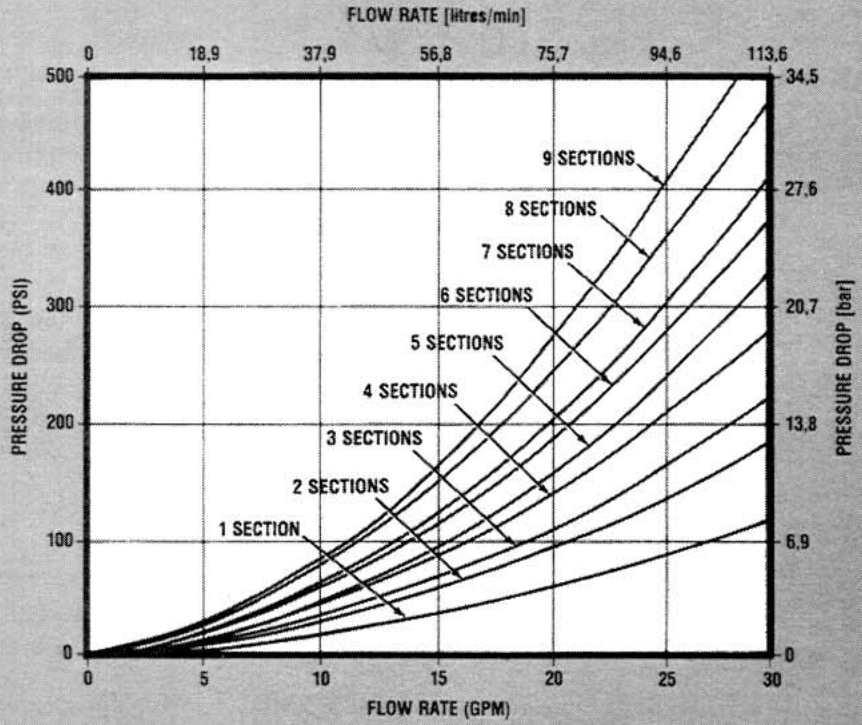

Left Top Inlet  
To Right End Outlet

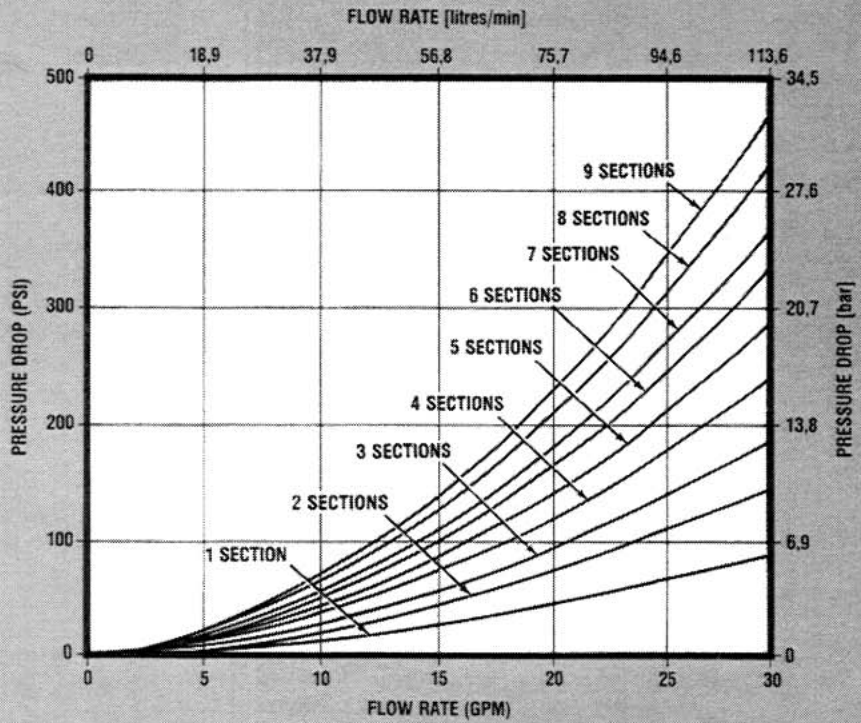

Curves derived from actual laboratory tests run with 150 SUS oil, at 100°F [38°C].  
SAE 12 inlet and outlet ports, and SAE 10 work ports.

# V20S (SERIES) INTERNAL PRESSURE DROP

Left Top Inlet  
To Work Port "A"

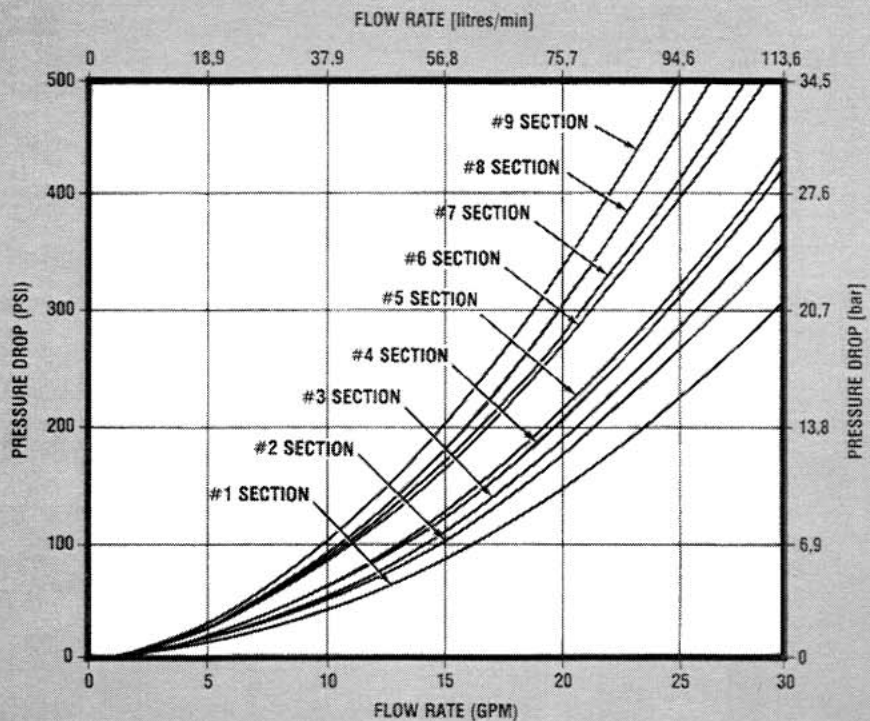

Left Top Inlet  
To Work Port "B"

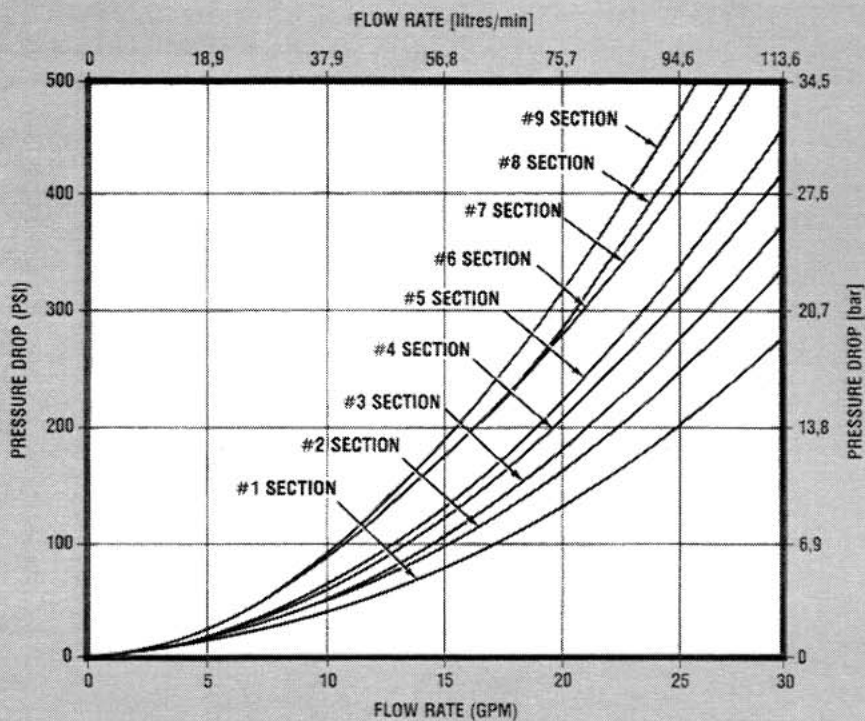

Curves derived from actual laboratory tests run with 150 SUS oil, at 100°F [38°C].  
SAE 12 inlet and outlet ports, and SAE 10 work ports.

# V20S (SERIES) INTERNAL PRESSURE DROP

Work Port "A"  
To Right End Outlet

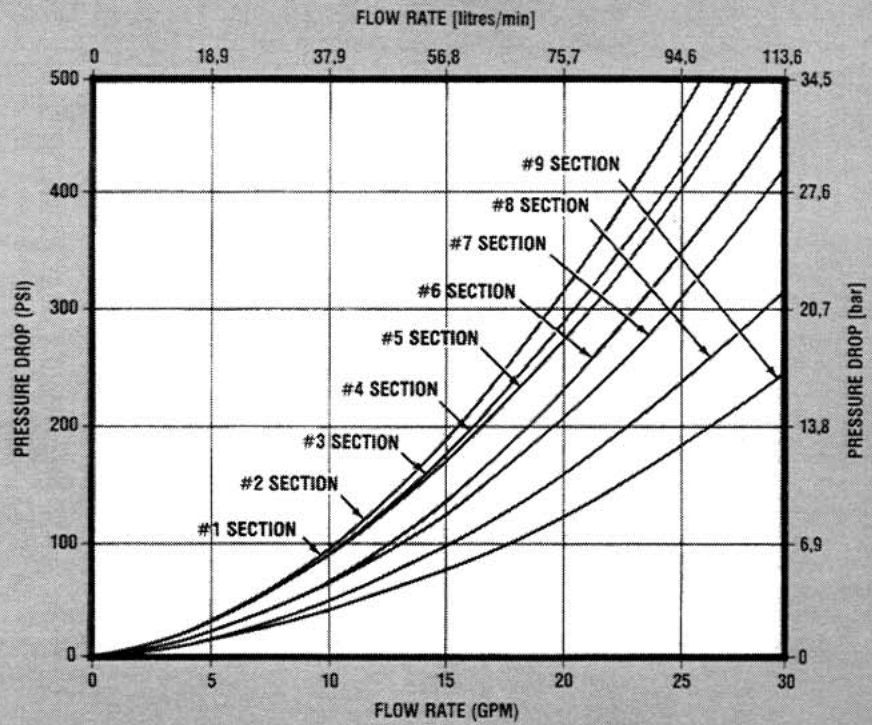

Work Port "B"  
To Right End Outlet

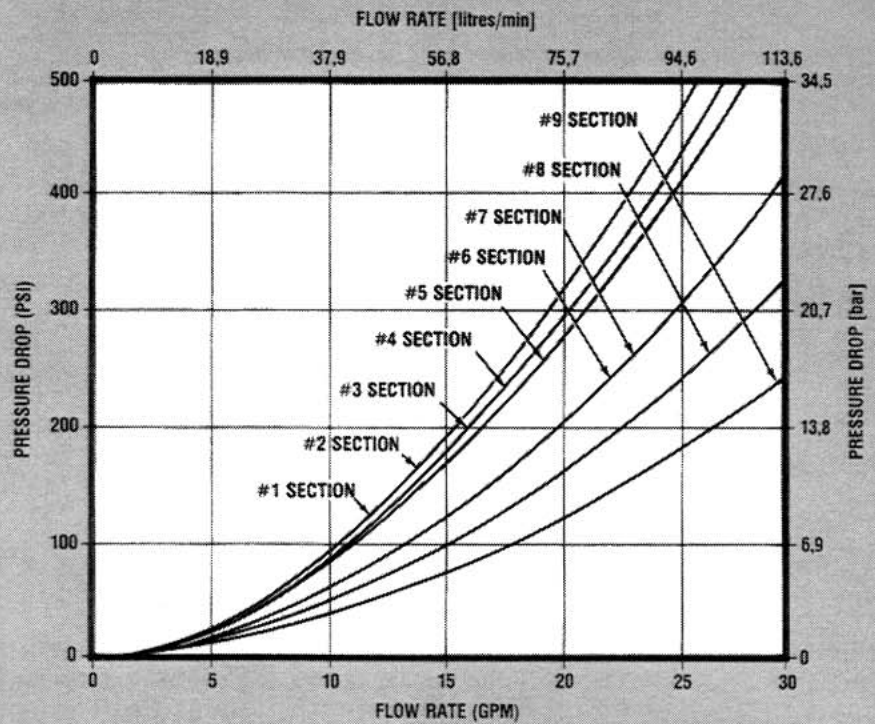

Curves derived from actual laboratory tests run with 150 SUS oil, at 100°F [38°C].  
SAE 12 inlet and outlet ports, and SAE 10 work ports.



# V20S (SERIES) INTERNAL PRESSURE DROP

Work Port "A" or "B"  
To Left End Outlet

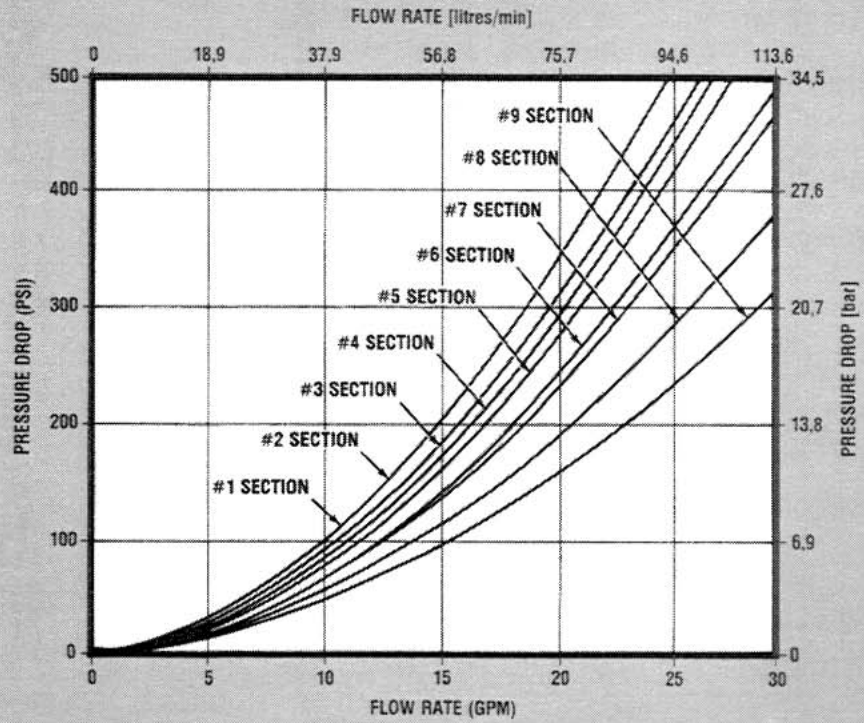

Curves derived from actual laboratory tests run with 150 SUS oil, at 100°F [38°C].  
SAE 12 inlet and outlet ports, and SAE 10 work ports.

## DIMENSIONS: TYPICAL MODEL V20P, V20T, V20PT, OR V20S VALVE ASSEMBLY

