

Vp1 Series Axial Piston Variable Displacement Pumps Installation Manual



| Contents..... | Page |
|--|-------------|
| Pump and Line selection..... | 12 |
| Specifications..... | 48 |
| VP1-045/-060/-075 cross section..... | 48 |
| Installation Dimensions, VP1-045, -060 and -075..... | 49 |
| LS valve block VP1-045/-060/-075..... | 50 |
| Through-shaft coupling VP1-045/-060/-075..... | 50 |
| VP1-095/-110/-130 cross section..... | 51 |
| LS control (for VP1-095/-110/-130)..... | 51 |
| Installation Dimensions, VP1-095/-110/-130..... | 52 |
| System Information..... | 53 |
| Ordering information..... | 53 |
| VP1 in load sensing systems and Systems comparison..... | 53 |
| LS load sensing control function and LS control adjustments..... | 54 |
| Suction fittings..... | 56 |
| Installation and start-up for VP1..... | 77 |

Specifications

| Frame size VP1 - | 045 | 060 | 075 | 095 | 110 | 130 |
|---|---------------|---------|---------|--------------------|--------------------|--------------------|
| Displacement [cm ³ /rev] | 45 | 60 | 75 | 95 | 110 | 128 |
| Max operating pressure [bar] | | | | | | |
| continuous | 350 | 350 | 350 | 400 | 400 | 400 |
| intermittent ¹⁾ | 400 | 400 | 400 | 420 | 420 | 420 |
| Mass moment of inertia J [kgm ²] | 0.00606 | 0.00606 | 0.00606 | 0.00681 | 0.00690 | 0.00690 |
| Shaft speed ²⁾ [rpm] | | | | | | |
| - short circuited pump (low press.) | 3000 | 3000 | 3000 | 3000 | 3000 | 3000 |
| - max selfpriming speed ²⁾ | 3000 | 2700 | 2500 | 2300 ³⁾ | 2200 ³⁾ | 2100 ³⁾ |
| Control type | LS | | | | | |
| Shaft end spline | DIN 5462 | | | | | |
| Mounting flange | ISO 7653-1985 | | | | | |
| Weight (with control) [kg] | 27 | | | | | |

¹⁾ Max 6 seconds in any one minute.

²⁾ At an inlet pressure of 1.0 bar (abs.) with mineral oil at a viscosity of 30 mm²/s (cSt).

³⁾ Valid with 3" inlet (suction) line

VP1-045/-060/-075 cross section

1. Inlet port
2. 'Top' purge plug
3. Return spring
4. Control
5. Setting piston (one of two)
6. Swash plate
7. Bearing shell
8. End cover
9. Spline (for mounting an auxiliary pump)
10. Plain bearing
11. Hold-down plunger
12. Valve plate
13. Cylinder barrel
14. Barrel housing
15. 'Bottom' purge plug
16. Piston with piston shoe
17. Retainer plate
18. Bearing housing
19. Roller bearing
20. Shaft seals with carrier
21. Input shaft

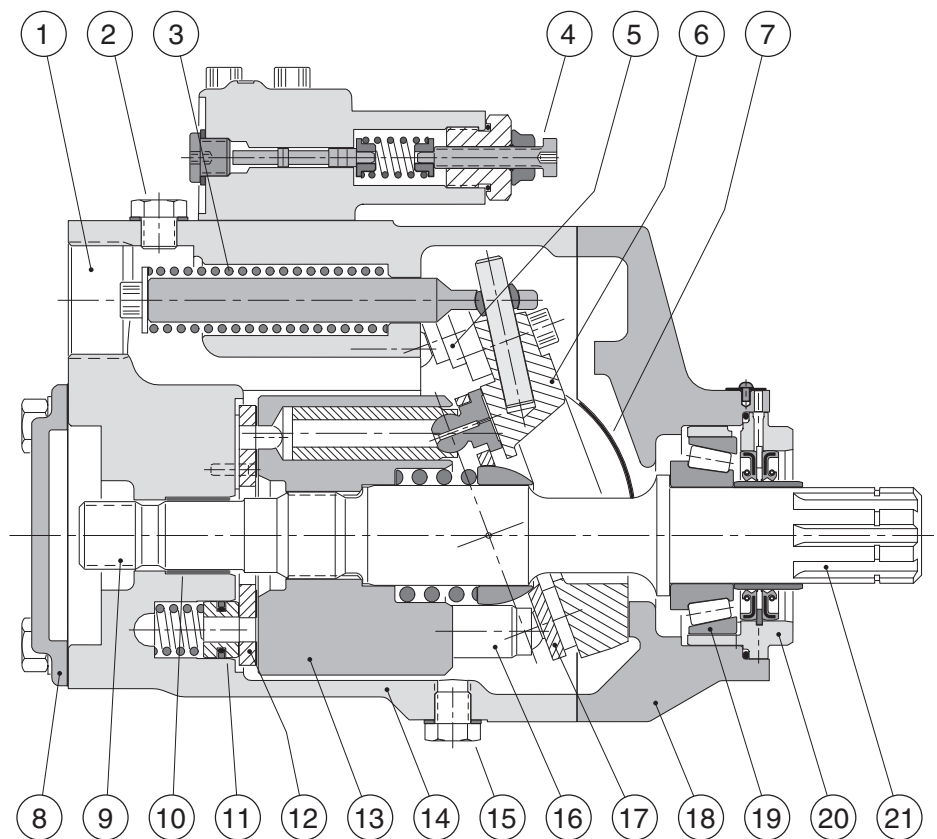

Installation Dimensions VP1-045, -60 and -075

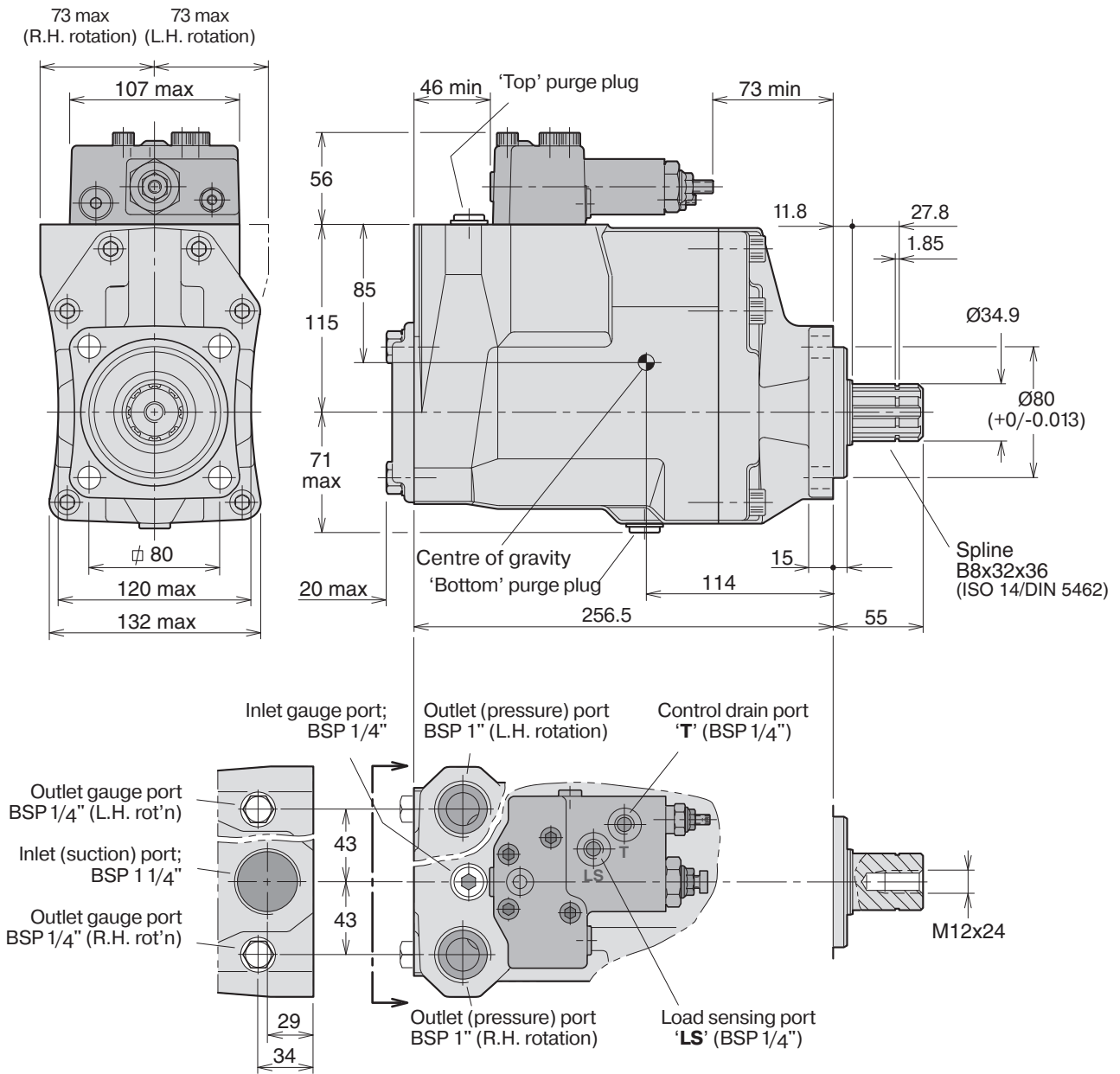

IMPORTANT
 The control is not drained through the pump case. An external line must be installed between the control drain port 'T' and the reservoir.

NOTE: The pump **does not** include a suction fitting; it must be ordered separately. See page 57ff.

LS valve block VP1-045/-060/-075

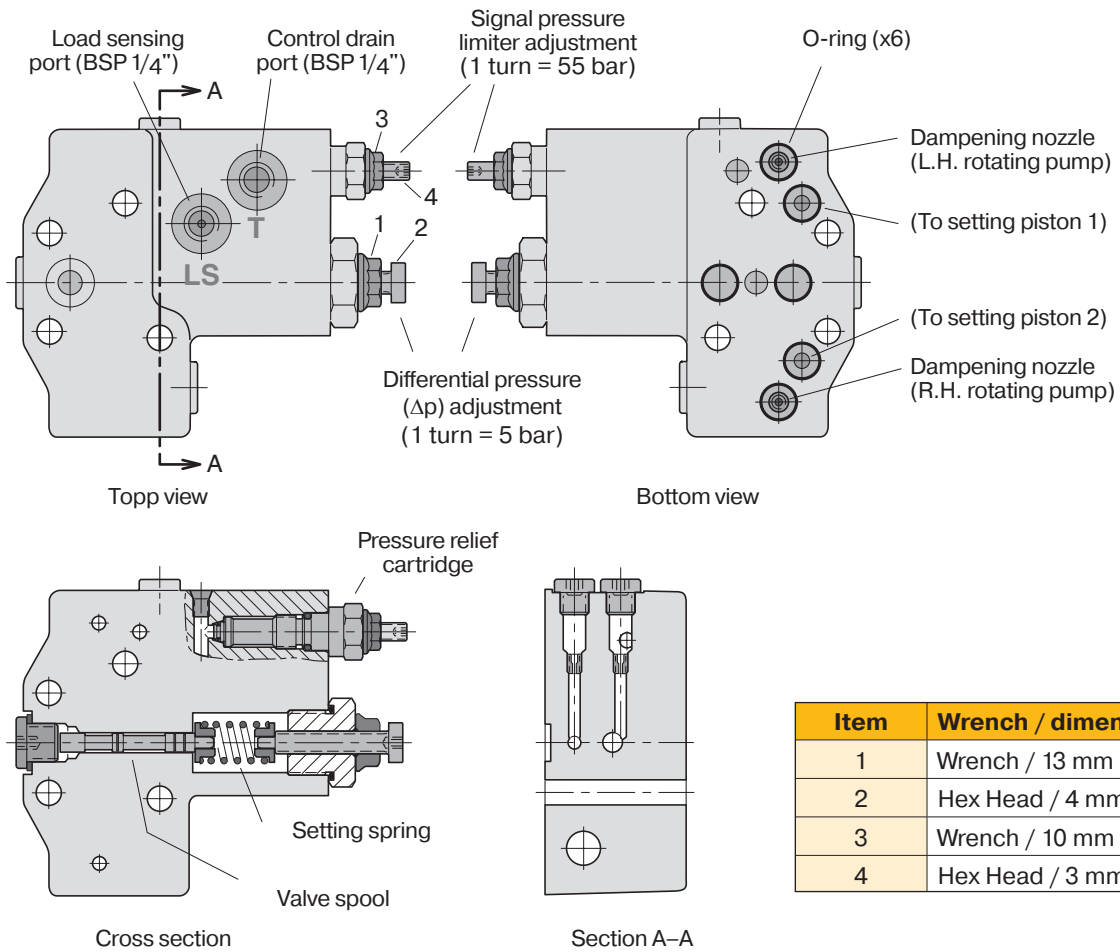

Fig. 2. LS valve block.

Through-shaft coupling VP1-045/-060/-075

The VP1 pump has a through-shaft which means that an additional pump, such as a fixed displacement F1, can be installed in tandem with the VP1 by means of an adaptor kit (fig. 3).

NOTE: The bending moment caused by the weight of a tandem assembly normally exceeds that allowed by the PTO.

To prevent damage, the auxiliary pump should be supported by a bracket attached

to the gearbox; it must not be fastened to the truck chassis.

Likewise, when the tandem assembly is installed on a separate bracket and driven by a cardan shaft, the auxiliary pump should have a support attached to the pump bracket.

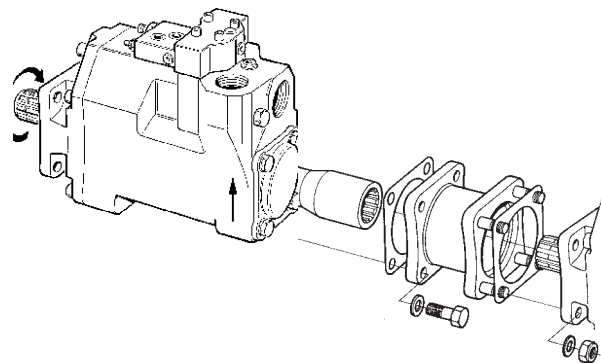
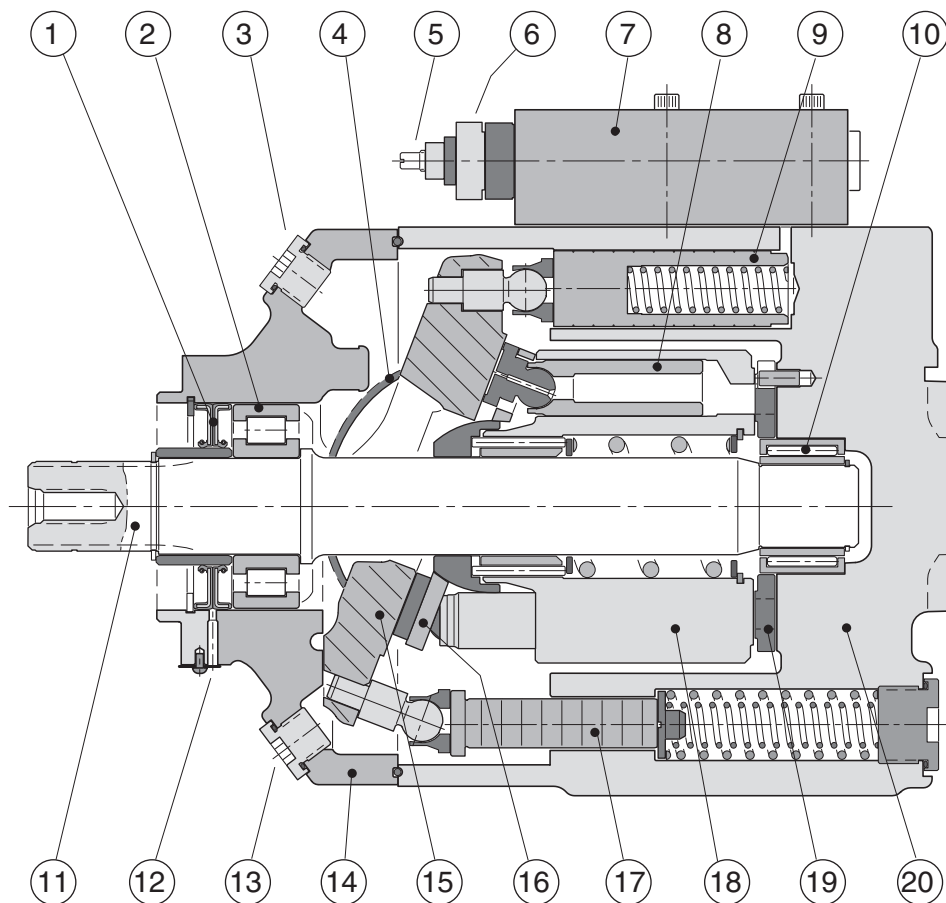

Fig. 3. Adaptor kit (P/N 379 7795) for tandem coupling.

IMPORTANT
 Contact Parker Hannifin for additional information when considering tandem mounting a second VP1 pump.
 The maximum torque that can be transmitted through the first pump VP1-045/-060/-075 in tandem is 420 Nm.

● **VP1-095/-110/-130 cross section**

1. Shaft seal
2. Roller bearing
3. 'Upper' purge plug
4. Bearing shell
5. Setting screw (pressure relief valve)
6. Setting bushing (standby pressure)
7. Control
8. Piston with piston shoe
9. 'Upper' setting piston (control pressure)
10. Needle bearing
11. Shaft
12. Drain hole, shaft seals
13. 'Lower' purge plug
14. Bearing housing
15. Swash plate
16. Retainer plate
17. 'Lower' setting piston (pump pressure)
18. Cylinder barrel
19. Valve plate
20. Barrel housing



● **LS control (for VP1-095/-110/-130)**

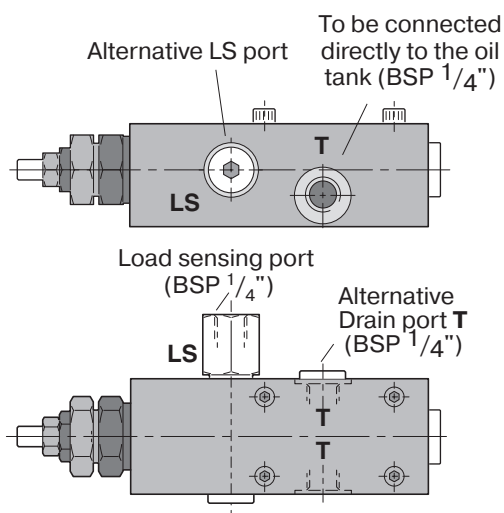

LS control ports.

NOTE:

Always run a function, after adjusting the standby pressure or the max pressure setting, before you read the value.

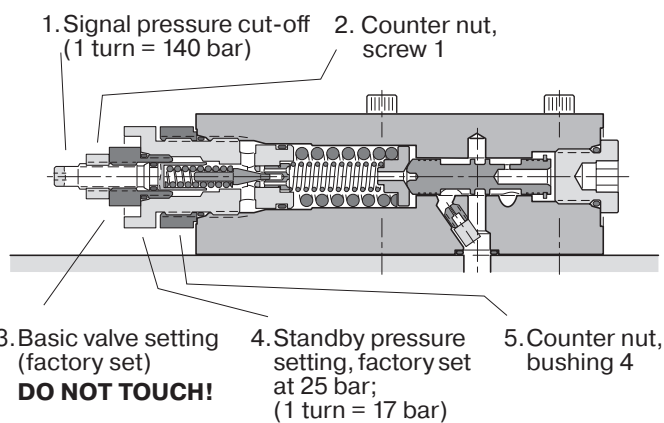

LS control cross section.

| Item | Wrench / dimension |
|------|------------------------|
| 1 | Hex Head Wrench / 4 mm |
| 2 | Wrench / 13 mm |
| 3 | DO NOT TOUCH |
| 4 | Wrench / 27 mm |
| 5 | Wrench / 27 mm |

VP1-095/-110/-130

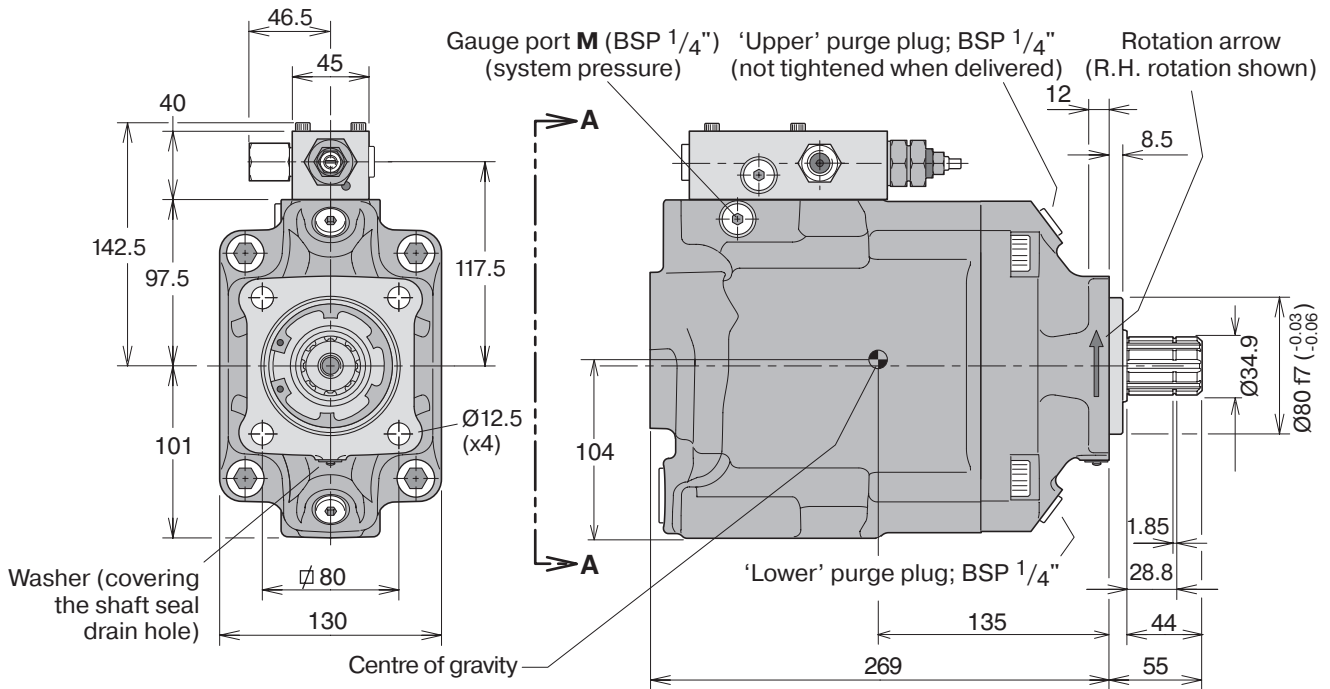

NOTE:
 The pump **does not** include a suction fitting; it must be ordered separately. See page 57ff.

IMPORTANT!
 The control is **not** drained through the pump case; an external drain line must be installed from control port T and, directly, to the oil tank.

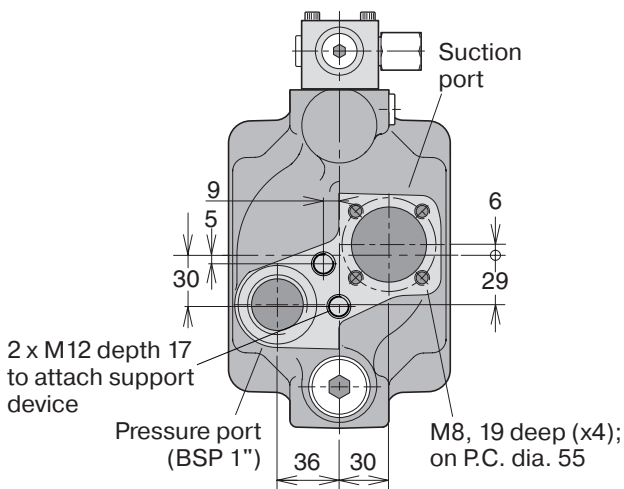
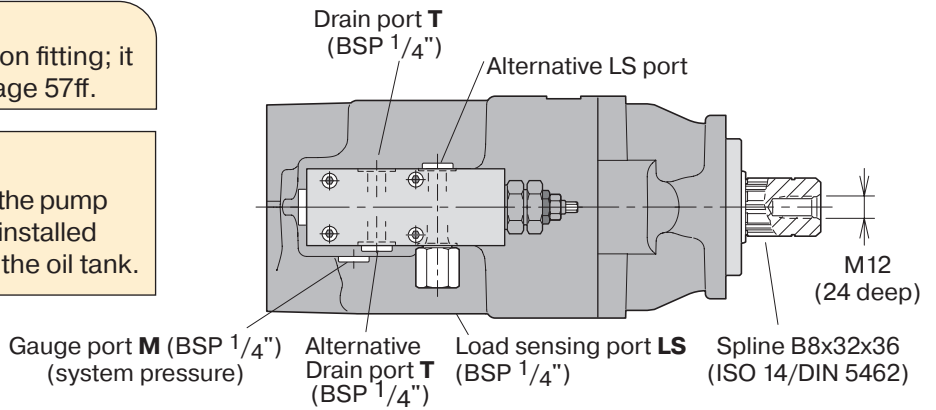

View A-A
Left hand rotating pump

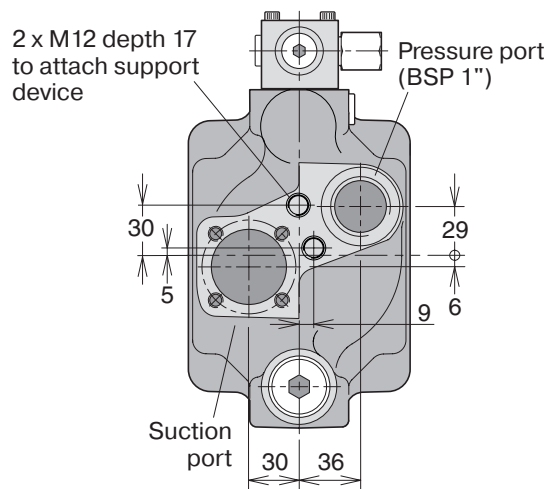

View A-A
Right hand rotating pump

Ordering information

Example: **VP1 - 045 - L**

Frame size **045, 060, 075, 095, 110 or 130**

Direction of rotation
L Left hand
R Right hand

NOTE:

The VP1 is uni-directional.
 Consequently, the desired direction of rotation must be stated when ordering.

VP1 in load sensing systems

When installed in a load sensing system, the VP1 supplies the correct amount of flow required by the various work functions currently engaged.

This means that energy consumption and heat generation are minimised and much reduced in comparison with a fixed displacement pump used in the same system.

Diagram 1 shows the required power (flow times pressure) in a constant flow system with a fixed displacement pump.

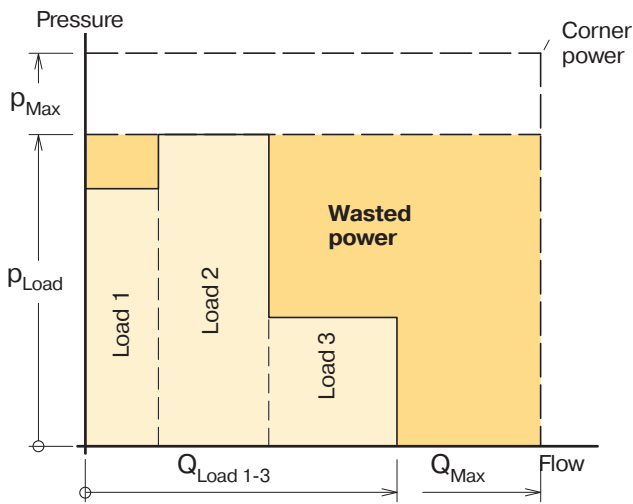

Diagram 1. Constant flow system with a fixed displacement pump.

Standard model numbers

| Designation | Ordering no. No Paint | Ordering no. Black Paint |
|-------------|-----------------------|--------------------------|
| VP1-045-R | 378 0334 | 378 6169 |
| VP1-045-L | 378 0335 | 378 6170 |
| VP1-060-R | 372 2283 | 372 2285 |
| VP1-060-L | 372 2284 | 372 2286 |
| VP1-075-R | 378 0336 | 378 6171 |
| VP1-075-L | 378 0337 | 378 6172 |
| VP1-095-R | 378 6000 | 378 6003 |
| VP1-095-L | 378 6001 | 378 6002 |
| VP1-110-R | 378 4110 | 378 3814 |
| VP1-110-L | 378 4111 | 378 3815 |
| VP1-130-R | 378 4500 | 378 4507 |
| VP1-130-L | 378 4501 | 378 4508 |

Diagram 2 shows the sharply reduced power requirement in a load sensing system with a variable displacement pump such as the VP1.

In both cases the pump pressure is slightly higher than what is required by the heaviest load ('Load 2') but the VP1, because of the much smaller flow being delivered, needs only the power indicated by the shaded area 'Load power'.

In a constant flow system, on the other hand, excess fluid is shunted to tank and the corresponding power, 'Wasted power' (shown in diagram 1), is a heat loss.

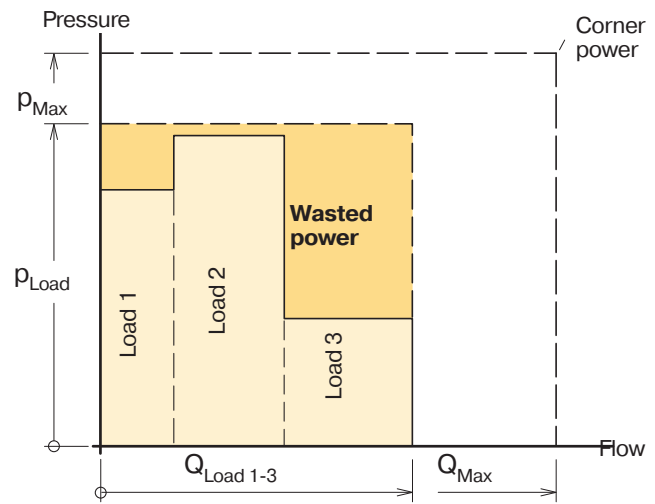

Diagram 2. Constant flow system with a variable displacement pump (e.g. VP1).

Systems comparison

| System Pump | Constant flow Fixed displ. | Load-sensing VP1 variable displ. |
|--------------------|----------------------------|----------------------------------|
| Pump adjustments | Pressure only | Pressure and flow |
| Load * | Some influence | Some influence |
| Energy consumption | High | Low |
| Heat generation | High | Low |

* Simultaneous operation of loads with non-equal flows and pressures; refer to the above diagrams.

LS load sensing control function

Refer to corresponding hydraulic schematic below.
 A selected 'opening' of the directional control valve spool corresponds to a certain flow to the work function. This flow, in turn, creates a pressure differential over the spool and, consequently, also a Δp between the pump outlet and the LS port.

When the differential pressure decreases (e.g. the directional valve is 'opened' further) the Δp also decreases and the LS valve spool moves to the left. The pressure to the setting pistons then decreases and the pump displacement increases.

The increase in pump displacement stops when the Δp finally reaches the setting (e.g. 25 bar) and the forces acting on the valve spool are equal.

If there is no LS signal pressure (e.g. when the directional valve is in the neutral, no-flow position) the pump only delivers sufficient flow to maintain the standby pressure as determined by the Δp setting.

LS control adjustments

Pressure limiter

| Pump size | Factory setting [bar] | Max pressure intermittent [bar] |
|-----------------|-----------------------|---------------------------------|
| VP1-045/060/075 | 350 | 400 |
| VP1-095/110/130 | 350 | 420 |

LS load sensing valve

| Pump size | Factory setting [bar] | Min pressure [bar] | Max pressure [bar] |
|-----------------|-----------------------|--------------------|--------------------|
| VP1-045/060/075 | 25 | 20 | 35 |
| VP1-095/110/130 | 25 | 15 | 40 |

The factory setting, and the standard orifice sizes shown in the corresponding schematic below, will usually provide an acceptable directional valve characteristic as well as system stability.

For additional information, contact Parker Hannifin.

Hydraulic schematic for VP1-45/-060/-075

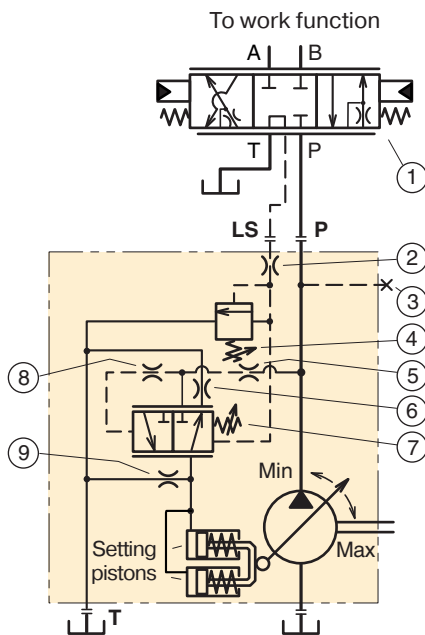

1. Directional, load sensing control valve
2. Load signal orifice (1.0 mm; fixed)
3. Gauge port
4. Signal pressure limiter adjustment
5. System pressure dampening nozzle (2.0 mm)
6. Return line nozzle (0.6 mm)
7. Standby (Δp) pressure adjustment
8. System pressure dampening orifice (fixed)
9. Bleed-off nozzle (0.6 mm).

Hydraulic schematic for VP1-095/-110/-130

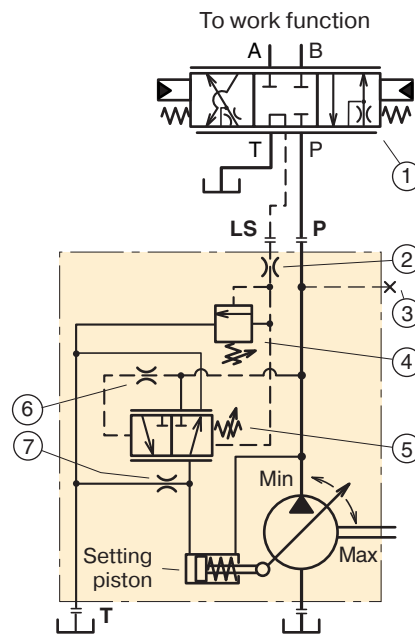

1. Directional, load sensing control valve
2. Load signal orifice (1.0 mm)
3. Gauge port
4. Signal pressure limiter adjustment
5. Standby (Δp) pressure adjustment
6. System pressure dampening orifice (fixed)
7. Bleed-off nozzle (1.2 mm)